

ESSENTIAL

MARVIN ESSENTIAL® COLLECTION



SPECIFICATION TABLE OF CONTENTS

2	ORDERING
3	LITE CUTS
4	CASEMENT
9	AWNING
13	CASEMENT PICTURE
15	CASEMENT TRANSOM
16	SINGLE HUNG
21	DOUBLE HUNG
26	GLIDER
27	GLIDER TRIPLE SASH
29	DOUBLE HUNG PICTURE
30	DOUBLE HUNG TRANSOM
31	DIRECT GLAZE ROUND TOPS
36	DIRECT GLAZE SPECIALTY SHAPES - POLYGONS
37	SLIDING PATIO DOOR
40	EGRESS OPENINGS
50	ALTITUDE GUIDELINES
55	SOUND TRANSMISSION
56	WDMA STANDARDS AND PERFORMANCE GRADE (PG)

ORDERING

Marvin Essential Collection products are sized with consistent nominal sizing to simplify specification and ordering.* Each product section offers product codes for ordering under each unit. Metric millimeter measurements are in parentheses.

You'll notice four measurements for each window or door: masonry opening, rough opening, frame size, and day light opening size. The masonry opening (MO) is for a home built with brick or stone; rough openings (RO) are for houses with wood, vinyl or metal siding. Frame size (FS) measures from edge to edge of the unit; daylight opening (DLO) indicates the dimension of total visible glass in a single sash.

MO (mm)	1' - 6" (457)	2' - 0" (610)	2' - 6" (762)	2' - 8" (914)	3' - 0" (914)	3' - 6" (1067)	4' - 0" (1219)
RO (mm)	1' - 6" (457)	2' - 0" (610)	2' - 6" (762)	2' - 8" (914)	3' - 0" (914)	3' - 6" (1067)	4' - 0" (1219)
FS (mm)	1' - 5 1/2" (445)	1' - 11 1/2" (597)	2' - 5 1/2" (749)	2' - 7 1/2" (902)	2' - 11 1/2" (902)	3' - 5 1/2" (1054)	3' - 11 1/2" (1207)
DLO (mm)	12 9/16" (319)	18 9/16" (471)	24 9/16" (624)	26 9/16" (675)	30 9/16" (776)	36 9/16" (929)	42 9/16" (1081)

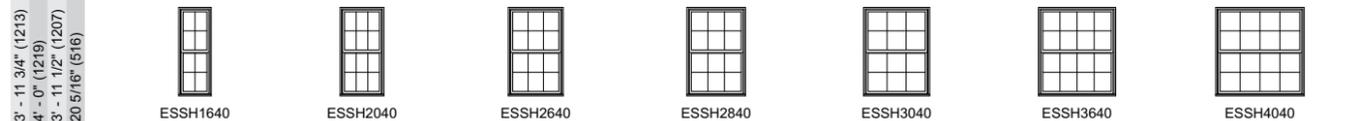

Mulling Options - A variety of standard factory mull and reinforced factory mull combinations are available.

Product Type	Standard Mull Max RO	MRF Mull Max RO	Assembly Configuration	Maximum Unit Assembly
Casement, Awning, & Picture	114" x 84"	114" x 84"	Ribbon Assembly	6W x 1H
	72" x 114"	72" x 114"	Stacked Assembly	1W x 5H
	72" x 96"	96" x 96"	Multi Wide x Multi High	5W x 5H
Single Hung, Double Hung, & Picture	114" x 78"	114" x 78"	Ribbon Assembly	6W x 1H
	60" x 96"	60" x 96"	Stacked Assembly	1W x 5H
	72" x 96"	96" x 96"	Multi Wide x Multi High	5W x 5H
Glider	114" x 60"	114" x 60"	Ribbon Assembly	3W x 1H
	72" x 96"	72" x 96"	Stacked Assembly	1W x 2H
	72" x 96"	96" x 96"	Multi Wide x Multi High	2W x 2H
Direct Glaze	114" x 96"	114" x 96"	Ribbon Assembly	6W x 1H
	96" x 114"	96" x 114"	Stacked Assembly	1W x 5H
	72" x 96"	96" x 96"	Multi Wide x Multi High	5W x 5H
DG Round Top	n/a	n/a	Ribbon Assembly	n/a
	96" x 114"	96" x 114"	Stacked Assembly	1W x 2H
	72" x 96"	96" x 96"	Multi Wide x Multi High	5W x 2H
DG Round Top (over glider)	n/a	n/a	Ribbon Assembly	n/a
	72" x 78"	72" x 78"	Stacked Assembly	1W x 2H
	72" x 78"	72" x 78"	Multi Wide x Multi High	2W x 2H
Sliding Patio Door	72" x 100"	72" x 100"	Stacked Assembly	1W x 2H

Note: Maximum assembly sizes may be limited due to individual unit size limits

OR Essential Mulling **Certification** Limits

Product Type	Standard Mull Max RO	MRF Mull Max RO	Assembly Configuration	Maximum Unit Assembly
Essential Windows	114" x 96"	114" x 96"	Ribbon Assembly	6W x 1H
	96" x 114"	96" x 114"	Stacked Assembly	1W x 5H
	72" x 96"	96" x 96"	Multi Wide x Multi High	5W x 5H
Sliding Patio Door	96" x 100"	96" x 100"	Stacked Assembly	1W x 2H

Note: Maximum assembly sizes may be limited due to individual unit size limits

Field mulling kits are available to create your own unique multiple assemblies. Field applied Essential mull kits are not WDMA certified.

*ESSH and ESDH units are only available on the bottom row of multi-high assemblies

**Mullion PG Rating may be determined by the lowest PG rating of the overall assembly. The Standard Mull has been certified to a PG25. The MRF Mull has been certified to a PG40.

Refer to the Essential Mull chapter of the ADM for detailed certification size limits, performance, and field mull information.

Please contact your local Marvin representative for more information.

Examples of Possible Configurations

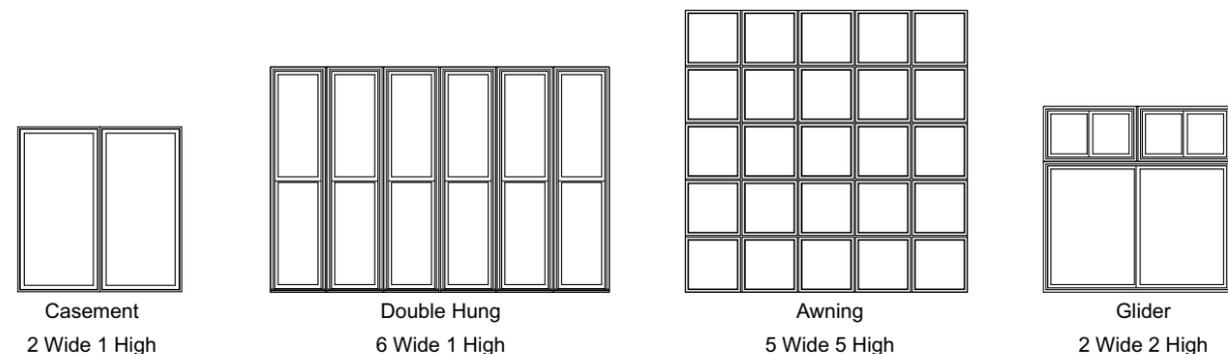

LITE CUTS GRILLES-BETWEEN-THE-GLASS (GBG)

Windows

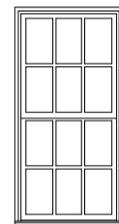

Rectangular
Available as GBG



Prairie
Available as GBG

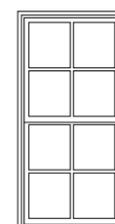

2w2h
Available as GBG

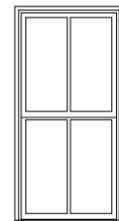

2w1h
Available as GBG

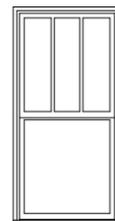

Equal Lite
Available as GBG

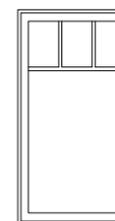

Cottage Lite
Available as GBG

Doors

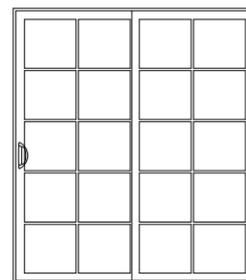

10/12 Lite
One vertical bar per panel
Available as GBG

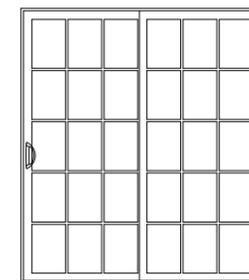

15/18 Lite
Two vertical bars per panel
Available as GBG

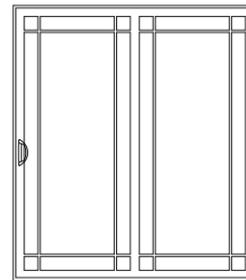

Prairie
Available as GBG

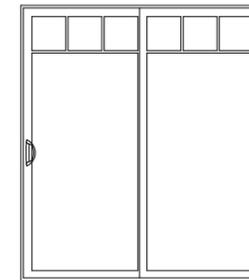

Cottage Lite
Available as GBG

Equal lite allows for the number of horizontal and vertical lites to be specified for a custom appearance.

Lite cuts are dependent on product type and size. Please consult your local Marvin representative for details and availability.

For further details and drawings visit the 'Technical Specifications' section at Marvin.com.

CASEMENT

MO (mm)	1' - 6" (457)	2' - 0" (610)	2' - 6" (762)	3' - 0" (914)
RO (mm)	1' - 6" (457)	2' - 0" (610)	2' - 6" (762)	3' - 0" (914)
FS (mm)	1' - 5 1/2" (445)	1' - 11 1/2" (597)	2' - 5 1/2" (749)	2' - 11 1/2" (902)
DLO (mm)	11 53/64" (300)	17 53/64" (453)	23 53/64" (605)	29 53/64" (757)

1' - 11 3/4" (603) 2' - 0" (610) 2' - 5 3/4" (756) 2' - 6" (762) 2' - 11 3/4" (908) 3' - 0" (914) 3' - 5 3/4" (1060) 3' - 6" (1067) 3' - 11 3/4" (1213) 4' - 0" (1219) 4' - 5 3/4" (1365) 4' - 6" (1372) 4' - 11 3/4" (1518) 5' - 0" (1524) 5' - 5 3/4" (1670) 5' - 6" (1676) 5' - 11 3/4" (1822) 6' - 0" (1829)	ESCA1620 ESCA1626 ESCA1630 ESCA1636 ESCA1640 ESCA1646 ESCA1650 ESCA1656 ESCA1660 T	ESCA2020 ESCA2026 ESCA2030 ESCA2036 ESCA2040 ESCA2046 ESCA2050 ESCA2056	ESCA2620* ESCA2626* ESCA2630* ESCA2636* ESCA2640 E* ESCA2646 E* ESCA2650 E* ESCA2656 E*	ESCA3020* ESCA3026* ESCA3030* ESCA3036 E* ESCA3040 E* ESCA3046 E* ESCA3050 E* ESCA3056 E* ESCA3060 ET*
---	--	--	--	--

CN Height	MO		RO		FS	
	in	mm	in	mm	in	mm
CN66	6' - 5 3/4"	(1975)	6' - 6"	(1981)	6' - 5 1/2"	(1969)
CN70	6' - 11 3/4"	(2128)	7' - 0"	(2134)	6' - 11 1/2"	(2121)

Details and Elevations not to scale.

Special sized units available within product size matrix. See your Marvin retailer.

E = These windows meet National Egress Codes for fire evacuation. Local codes may differ.

T = Standard Tempered

Obscure Glass option available on all units.

GBG available in standard rectangular lite cut, shown above. Other GBG lite cuts shown on page 3.

See page 56 for specific PG Ratings.

For further details and drawings visit the 'Technical Specifications' section at Marvin.com.

* These units may optionally include a window opening control device tested to ASTM F2090-10, which can be released from the inside without the use of a key, tool, special knowledge, or force greater than that required for normal unit operation.

WOCD not available on CN66 and CN70 heights

CASEMENT

2 Wide

MO (mm)	3' - 0" (914)	4' - 0" (1219)	5' - 0" (1524)	6' - 0" (1829)
RO (mm)	3' - 0" (914)	4' - 0" (1219)	5' - 0" (1524)	6' - 0" (1829)
FS (mm)	2' - 11 1/2" (902)	3' - 11 1/2" (1207)	4' - 11 1/2" (1511)	5' - 11 1/2" (1816)

1' - 11 3/4" (603) 2' - 5 3/4" (756) 2' - 6" (762) 2' - 11 3/4" (908) 3' - 0" (914) 3' - 5 3/4" (1060) 3' - 6" (1067) 3' - 11 3/4" (1213) 4' - 0" (1219) 4' - 5 3/4" (1365) 4' - 6" (1372) 4' - 11 3/4" (1518) 5' - 0" (1524) 5' - 5 3/4" (1670) 5' - 6" (1676) 5' - 11 3/4" (1822) 6' - 0" (1829)	ESCA1620 ESCA1626 ESCA1630 ESCA1636 ESCA1640 ESCA1646 ESCA1650 ESCA1656 ESCA1660 T	ESCA2020 ESCA2026 ESCA2030 ESCA2036 ESCA2040 ESCA2046 ESCA2050 ESCA2056 ESCA2060 T	ESCA2620* ESCA2626* ESCA2630* ESCA2636* ESCA2640 E* ESCA2646 E* ESCA2650 E* ESCA2656 E*	ESCA3020* ESCA3026* ESCA3030* ESCA3036 E* ESCA3040 E* ESCA3046 E* ESCA3050 E* ESCA3056 E* ESCA3060 ET*
--	--	--	--	--

CN Height	MO		RO		FS	
	in	mm	in	mm	in	mm
CN66	6' - 5 3/4"	(1975)	6' - 6"	(1981)	6' - 5 1/2"	(1969)
CN70	6' - 11 3/4"	(2128)	7' - 0"	(2134)	6' - 11 1/2"	(2121)

Construction Details

Casements available as an operator or stationary.

L or R handing determined from exterior.

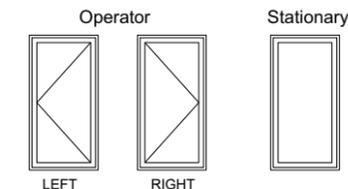

CASEMENT

3 Wide

MO (mm)	4' - 6" (1372)	6' - 0" (1829)	7' - 6" (2286)	9' - 0" (2743)
RO (mm)	4' - 6" (1372)	6' - 0" (1829)	7' - 6" (2286)	9' - 0" (2743)
FS (mm)	4' - 5 1/2" (1359)	5' - 11 1/2" (1816)	7' - 5 1/2" (2273)	8' - 11 1/2" (2731)

1' - 11 3/4" (603) 2' - 0" (610) 1' - 11 1/2" (597)	 ESCA1620	 ESCA2020	 ESCA2620*	 ESCA3020*
2' - 5 3/4" (756) 2' - 6" (762) 2' - 5 1/2" (749)	 ESCA1626	 ESCA2026	 ESCA2626*	 ESCA3026*
2' - 11 3/4" (908) 3' - 0" (914) 2' - 11 1/2" (902)	 ESCA1630	 ESCA2030	 ESCA2630*	 ESCA3030*
3' - 5 3/4" (1060) 3' - 6" (1067) 3' - 5 1/2" (1054)	 ESCA1636	 ESCA2036	 ESCA2636*	 ESCA3036 E*
3' - 11 3/4" (1213) 4' - 0" (1219) 3' - 11 1/2" (1207)	 ESCA1640	 ESCA2040	 ESCA2640 E*	 ESCA3040 E*
4' - 5 3/4" (1365) 4' - 6" (1372) 4' - 5 1/2" (1359)	 ESCA1646	 ESCA2046	 ESCA2646 E*	 ESCA3046 E*
4' - 11 3/4" (1518) 5' - 0" (1524) 4' - 11 1/2" (1511)	 ESCA1650	 ESCA2050	 ESCA2650 E*	 ESCA3050 E*
5' - 5 3/4" (1670) 5' - 6" (1676) 5' - 5 1/2" (1664)	 ESCA1656	 ESCA2056	 ESCA2656 E*	 ESCA3056 E*
5' - 11 3/4" (1822) 6' - 0" (1829) 5' - 11 1/2" (1816)	 ESCA1660 T	 ESCA2060 T	 ESCA2660 ET*	 ESCA3060 ET*

Details and Elevations not to scale.

Special sized units available within product size matrix. See your Marvin retailer.

E = These windows meet National Egress Codes for fire evacuation. Local codes may differ.

T = Standard Tempered

Obscure Glass option available on all units.

GBG available in standard Rectangular lite cut, shown above. Other GBG lite cuts shown on page 3.

See page 56 for specific PG Ratings.

For further details and drawings visit the 'Technical Specifications' section at Marvin.com.

* These units may optionally include a window opening control device tested to ASTM F2090-10, which can be released from the inside without the use of a key, tool, special knowledge, or force greater than that required for normal unit operation.

WOCD not available on CN66 and CN70.

CASEMENT

4 Wide

MO (mm)	6' - 0" (1829)	8' - 0" (2438)
RO (mm)	6' - 0" (1829)	8' - 0" (2438)
FS (mm)	5' - 11 1/2" (1816)	7' - 11 1/2" (2426)

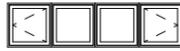
1' - 11 3/4" (603) 2' - 0" (610) 1' - 11 1/2" (597)	 ESCA1620	 ESCA2020
2' - 5 3/4" (756) 2' - 6" (762) 2' - 5 1/2" (749)	 ESCA1626	 ESCA2026
2' - 11 3/4" (908) 3' - 0" (914) 2' - 11 1/2" (902)	 ESCA1630	 ESCA2030
3' - 5 3/4" (1060) 3' - 6" (1067) 3' - 5 1/2" (1054)	 ESCA1636	 ESCA2036
3' - 11 3/4" (1213) 4' - 0" (1219) 3' - 11 1/2" (1207)	 ESCA1640	 ESCA2040
4' - 5 3/4" (1365) 4' - 6" (1372) 4' - 5 1/2" (1359)	 ESCA1646	 ESCA2046
4' - 11 3/4" (1518) 5' - 0" (1524) 4' - 11 1/2" (1511)	 ESCA1650	 ESCA2050
5' - 5 3/4" (1670) 5' - 6" (1676) 5' - 5 1/2" (1664)	 ESCA1656	 ESCA2056
5' - 11 3/4" (1822) 6' - 0" (1829) 5' - 11 1/2" (1816)	 ESCA1660 T	 ESCA2060 T

CN Height	MO		RO		FS	
	in	mm	in	mm	in	mm
CN66	6' - 5 3/4"	(1975)	6' - 6"	(1981)	6' - 5 1/2"	(1969)
CN70	6' - 11 3/4"	(2128)	7' - 0"	(2134)	6' - 11 1/2"	(2121)

Casement Flankers with Center Picture

MO (mm)	8' - 0" (2438)
RO (mm)	8' - 0" (2438)
FS (mm)	7' - 11 1/2" (2426)

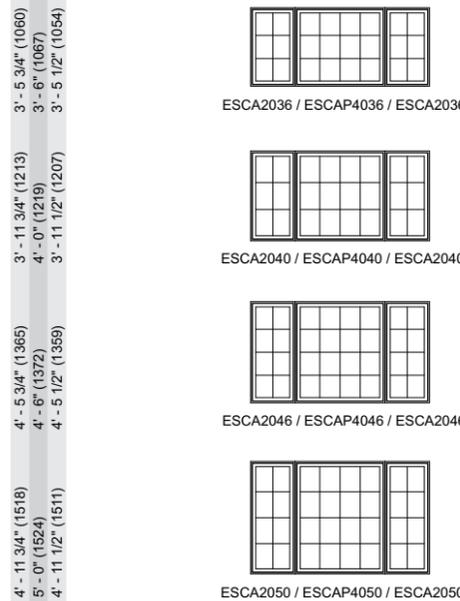

Casement Flankers with Center Picture

MO (mm)	9' - 0" (2743)
RO (mm)	9' - 0" (2743)
FS (mm)	8' - 11 1/2" (2731)

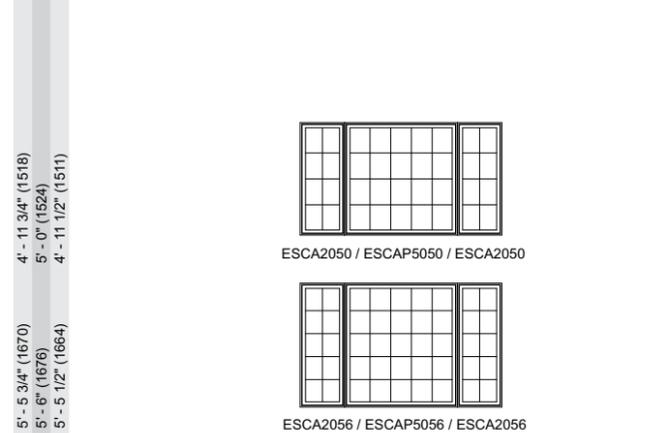

CN Height	MO		RO		FS	
	in	mm	in	mm	in	mm
CN66	6' - 5 3/4"	(1975)	6' - 6"	(1981)	6' - 5 1/2"	(1969)
CN70	6' - 11 3/4"	(2128)	7' - 0"	(2134)	6' - 11 1/2"	(2121)

Construction Details

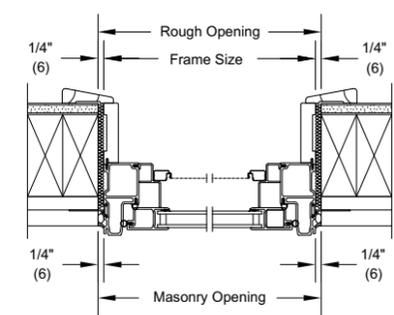

Jambs

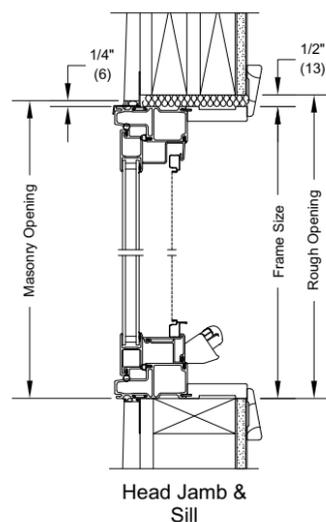

Head Jamb & Sill

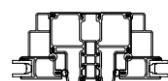

Vertical Mull
Casement/Awning/Picture To
Casement/Awning/Picture



Horizontal Mull
Casement/Awning/Picture To
Casement/Awning/Picture

MULLED ASSEMBLIES

Units can be factory mulled.

MAXIMUM ROUGH OPENING not to exceed 114" x 84". Maximum up to 6 units wide by 1 unit high.

MAXIMUM ROUGH OPENING not to exceed 72" x 114". Maximum up to 1 unit wide by 5 units high.

For Multi-Wide Multi-High assemblies, MAXIMUM ROUGH OPENING not to exceed 96" x 96". Maximum up to 5 units wide by 5 units high.

Field mull kits are available. Structural mullion reinforcement is required for some assemblies.

Please consult your local Marvin representative for more information.

AWNING

MO (mm)	1' - 6" (457)	2' - 0" (610)	2' - 6" (762)	3' - 0" (914)	3' - 6" (1067)	4' - 0" (1219)	4' - 6" (1372)	5' - 0" (1524)
RO (mm)	1' - 6" (457)	2' - 0" (610)	2' - 6" (762)	3' - 0" (914)	3' - 6" (1067)	4' - 0" (1219)	4' - 6" (1372)	5' - 0" (1524)
FS (mm)	1' - 5 1/2" (445)	1' - 11 1/2" (597)	2' - 5 1/2" (749)	2' - 11 1/2" (902)	3' - 5 1/2" (1054)	3' - 11 1/2" (1207)	4' - 5 1/2" (1359)	4' - 11 1/2" (1511)
DLO (mm)	11 53/64" (300)	17 53/64" (453)	23 53/64" (605)	29 53/64" (757)	35 53/64" (910)	41 53/64" (1062)	47 53/64" (1215)	53 53/64" (1367)

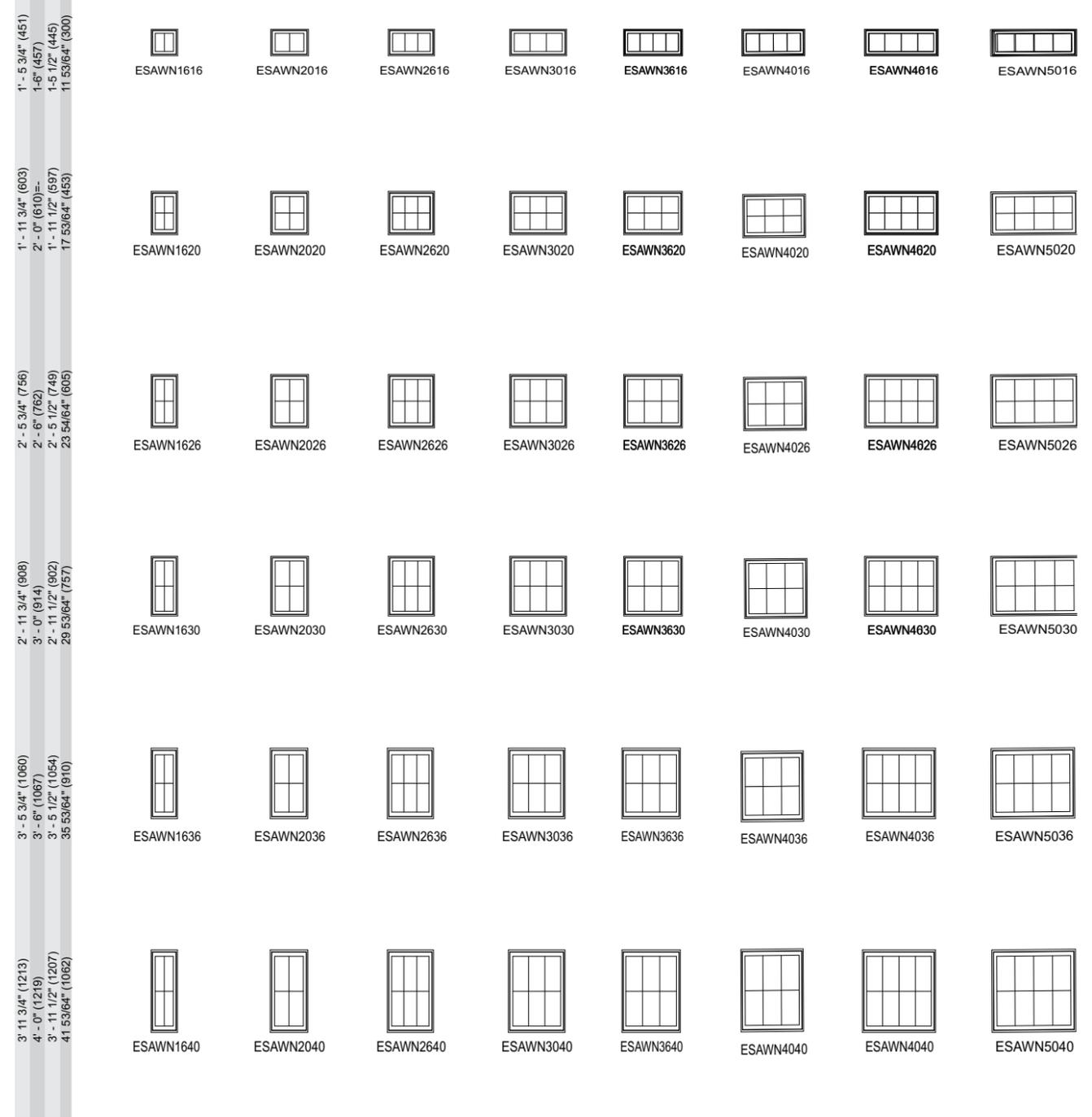

Details and Elevations not to scale.

Special sized units available within product size matrix. See your Marvin retailer.

Obscure Glass option available on all units.

GBG available in standard Rectangular lite cut, shown above. Other GBG lite cuts shown on page 3.

See page 56 for specific PG Ratings.

For further details and drawings visit the 'Technical Specifications' section at Marvin.com.

AWNING

2 Wide

MO (mm)	3' - 0" (914)	4' - 0" (1219)	5' - 0" (1524)	6' - 0" (1829)	7' - 0" (2134)	8' - 0" (2438)
RO (mm)	3' - 0" (914)	4' - 0" (1219)	5' - 0" (1524)	6' - 0" (1829)	7' - 0" (2134)	8' - 0" (2438)
FS (mm)	2' - 11 1/2" (902)	3' - 11 1/2" (1207)	4' - 11 1/2" (1511)	5' - 11 1/2" (1816)	6' - 11 1/2" (2121)	7' - 11 1/2" (2426)

1' - 5 3/4" (451) 1' - 6" (457) 1' - 5 1/2" (445)	 ESAWN1616	 ESAWN2016	 ESAWN2616	 ESAWN3016	 ESAWN3616	 ESAWN4016
1' - 11 3/4" (603) 2' - 0" (610) 1' - 5 1/2" (597)	 ESAWN1620	 ESAWN2020	 ESAWN2620	 ESAWN3020	 ESAWN3620	 ESAWN4020
2' - 5 3/4" (756) 2' - 6" (762) 2' 5 1/2" (749)	 ESAWN1626	 ESAWN2026	 ESAWN2626	 ESAWN3026	 ESAWN3626	 ESAWN4026
2' - 11 3/4" (908) 3' - 0" (914) 2' - 11 1/2" (902)	 ESAWN1630	 ESAWN2030	 ESAWN2630	 ESAWN3030	 ESAWN3630	 ESAWN4030
3' - 5 3/4" (1060) 3' - 6" (1067) 3' - 5 1/2" (1054)	 ESAWN1636	 ESAWN2036	 ESAWN2636	 ESAWN3036	 ESAWN3636	 ESAWN4036
3' - 11 3/4" (1213) 4' - 0" (1219) 3' - 11 1/2" (1207)	 ESAWN1640	 ESAWN2040	 ESAWN2640	 ESAWN3040	 ESAWN3640	 ESAWN4040

Details and Elevations not to scale.

Special sized units available within product size matrix.
See your Marvin retailer.

See page 56 for specific PG Ratings.

For further details and drawings visit the 'Technical Specifications' section at Marvin.com.

AWNING

3 Wide

MO (mm)	4' - 6" (1372)	6' - 0" (1829)	7' - 6" (2286)	9' - 0" (2743)
RO (mm)	4' - 6" (1372)	6' - 0" (1829)	7' - 6" (2286)	9' - 0" (2743)
FS (mm)	4' - 5 1/2" (1359)	5' - 11 1/2" (1816)	7' - 5 1/2" (2273)	8' - 11 1/2" (2731)

1' - 5 3/4" (451) 1' - 6" (457) 1' - 5 1/2" (445)	 ESAWN1616	 ESAWN2016	 ESAWN2616	 ESAWN3016
1' - 11 3/4" (603) 2' - 0" (610) 1' - 11 1/2" (597)	 ESAWN1620	 ESAWN2020	 ESAWN2620	 ESAWN3020
2' - 5 3/4" (756) 2' - 6" (762) 2' 5 1/2" (749)	 ESAWN1626	 ESAWN2026	 ESAWN2626	 ESAWN3026
2' - 11 3/4" (908) 3' - 0" (914) 2' - 11 1/2" (902)	 ESAWN1630	 ESAWN2030	 ESAWN2630	 ESAWN3030
3' - 5 3/4" (1060) 3' - 6" (1067) 3' - 5 1/2" (1054)	 ESAWN1636	 ESAWN2036	 ESAWN2636	 ESAWN3036
3' - 11 3/4" (1213) 4' - 0" (1219) 3' - 11 1/2" (1207)	 ESAWN1640	 ESAWN2040	 ESAWN2640	 ESAWN3040

AWNING

4 Wide

MO (mm)	6' - 0" (1829)	8' - 0" (2438)
RO (mm)	6' - 0" (1829)	8' - 0" (2438)
FS (mm)	5' - 11 1/2" (1816)	7' - 11 1/2" (2426)

1' - 5 3/4" (451)		
1' - 6" (457)		
1' - 5 1/2" (445)		
1' - 11 3/4" (603)		
2' - 0" (610)		
1' - 11 1/2" (597)		
2' - 5 3/4" (756)		
2' - 6" (762)		
2' - 5 1/2" (749)		
2' - 11 3/4" (908)		
3' - 0" (914)		
2' - 11 1/2" (902)		
3' - 5 3/4" (1060)		
3' - 6" (1067)		
3' - 5 1/2" (1054)		
3' - 11 3/4" (1213)		
4' - 0" (1219)		
3' - 11 1/2" (1207)		

Construction Details

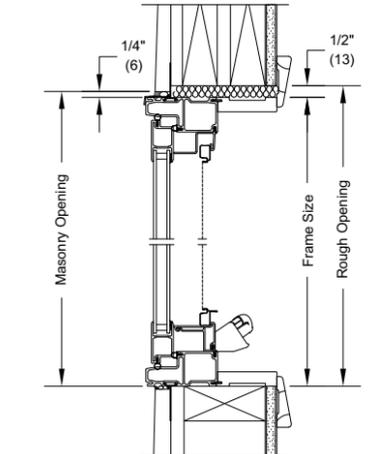

Head Jamb & Sill

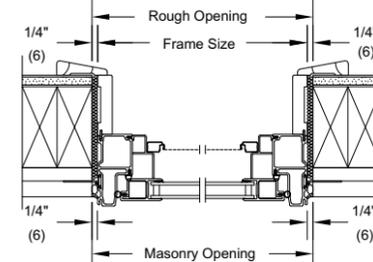

Jamb

Vertical Mull Casement/Awning/Picture To Casement/Awning/Picture

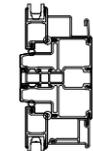

Horizontal Mull Casement/Awning/Picture To Casement/Awning/Picture

MULLED ASSEMBLIES
 Units can be factory mulled.
 MAXIMUM ROUGH OPENING not to exceed 114" x 84". Maximum up to 6 units wide by 1 unit high.
 MAXIMUM ROUGH OPENING not to exceed 72" x 114". Maximum up to 1 unit wide by 5 units high.
 For Multi-Wide Multi-High assemblies, MAXIMUM ROUGH OPENING not to exceed 96" x 96". Maximum up to 5 units wide by 5 units high.
 Field mull kits are available. Structural mullion reinforcement is required for some assemblies.
 Please consult your local Marvin representative for more information.

CASEMENT PICTURE

MO (mm)	1' - 6" (457)	2' - 0" (610)	2' - 6" (762)	3' - 0" (914)	3' - 6" (1067)	4' - 0" (1219)	4' - 6" (1372)
RO (mm)	1' - 6" (457)	2' - 0" (610)	2' - 6" (762)	3' - 0" (914)	3' - 6" (1067)	4' - 0" (1219)	4' - 6" (1372)
FS (mm)	1' - 5 1/2" (445)	1' - 11 1/2" (597)	2' - 5 1/2" (749)	2' - 11 1/2" (902)	3' - 5 1/2" (1054)	3' - 11 1/2" (1207)	4' - 5 1/2" (1359)
DLO (mm)	11 53/64" (300)	17 53/64" (453)	23 53/64" (605)	29 53/64" (757)	35 53/64" (910)	41 53/64" (1062)	47 53/64" (1215)

1' - 11 3/4" (603)							
1' - 11 1/2" (597)							
2' - 5 3/4" (756)							
2' - 6" (762)							
2' - 5 1/2" (749)							
2' - 11 3/4" (908)							
3' - 0" (914)							
2' - 11 1/2" (902)							
29 53/64" (757)							
3' - 5 3/4" (1060)							
3' - 6" (1067)							
3' - 5 1/2" (1054)							
3' - 11 3/4" (1213)							
4' - 0" (1219)							
3' - 11 1/2" (1207)							
41 53/64" (1062)							
4' - 5 3/4" (1365)							
4' - 6" (1372)							
4' - 5 1/2" (1359)							
4' - 11 3/4" (1518)							
5' - 0" (1524)							
4' - 11 1/2" (1511)							
53 53/64" (1367)							
5' - 5 3/4" (1670)							
5' - 6" (1676)							
5' - 5 1/2" (1664)							
59 53/64" (1519)							
5' - 11 3/4" (1822)							
6' - 0" (1829)							
5' - 11 1/2" (1816)							
65 53/64" (1672)							

Details and Elevations not to scale.
 Special sized units available within product size matrix. See your Marvin retailer.
 T = Standard Tempered.

GBG available in standard Rectangular lite cut, shown above. Other GBG lite cuts shown on page 3.
 See page 56 for specific PG Ratings.
 For further details and drawings visit the 'Technical Specifications' section at Marvin.com.

CASEMENT PICTURE

MO (mm)	5' - 0" (1524)	6' - 0" (1829)
RO (mm)	5' - 0" (1524)	6' - 0" (1829)
FS (mm)	4' - 11 1/2" (1511)	5' - 11 1/2" (1816)
DLO (mm)	53 53/64" (1367)	65 53/64" (1672)

1' - 11 3/4" (603)		
2' - 0" (610)		
2' - 5 3/4" (756)		
2' - 6" (762)		
2' - 11 3/4" (908)		
3' - 0" (914)		
3' - 5 3/4" (1060)		
3' - 6" (1067)		
3' - 11 3/4" (1213)		
4' - 0" (1219)		
4' - 5 3/4" (1365)		
4' - 6" (1372)		
4' - 11 3/4" (1518)		
5' - 0" (1524)		
5' - 5 3/4" (1670)		
5' - 6" (1676)		
5' - 11 3/4" (1822)		
6' - 0" (1829)		
6' - 5 3/4" (1975)		
6' - 6" (1969)		
6' - 11 3/4" (2122)		
7' - 0" (2134)		

CN Height	MO		RO		FS	
	in	mm	in	mm	in	mm
CN66	6' - 5 3/4"	(1975)	6' - 6"	(1981)	6' - 5 1/2"	(1969)
CN70	6' - 11 3/4"	(2128)	7' - 0"	(2134)	6' - 11 1/2"	(2121)

Details and Elevations not to scale.
 Special sized units available within product size matrix. See your Marvin retailer.
 T = Standard Tempered.
 GBG available on all sizes in standard

Rectangular lite cut, shown above.
 Other GBG lite cuts shown on page 3.
 See page 56 for specific PG Ratings.
 For further details and drawings visit the "Technical Specifications" section at Marvin.com.

CASEMENT TRANSOM

MO (mm)	1' - 6" (457)	2' - 0" (610)	2' - 6" (762)	3' - 0" (914)	3' - 6" (1067)	4' - 0" (1219)	5' - 0" (1524)	6' - 0" (1829)
RO (mm)	1' - 6" (457)	2' - 0" (610)	2' - 6" (762)	3' - 0" (914)	3' - 6" (1067)	4' - 0" (1219)	5' - 0" (1524)	6' - 0" (1829)
FS (mm)	1' - 5 1/2" (445)	1' - 11 1/2" (597)	2' - 5 1/2" (749)	2' - 11 1/2" (902)	3' - 5 1/2" (1054)	3' - 11 1/2" (1207)	4' - 11 1/2" (1511)	5' - 11 1/2" (1816)
DLO (mm)	11 53/64" (300)	17 53/64" (453)	23 53/64" (605)	29 53/64" (757)	35 53/64" (910)	41 53/64" (1062)	53 53/64" (1367)	65 53/64" (1672)

0' - 11 3/4" (298)								
1' - 0" (305)								
1' - 5 3/4" (451)								
1' - 6" (457)								
1' - 11 1/2" (597)								
1' - 5 1/2" (445)								
1' - 11 1/2" (597)								
17 53/64" (453)								

Construction Details

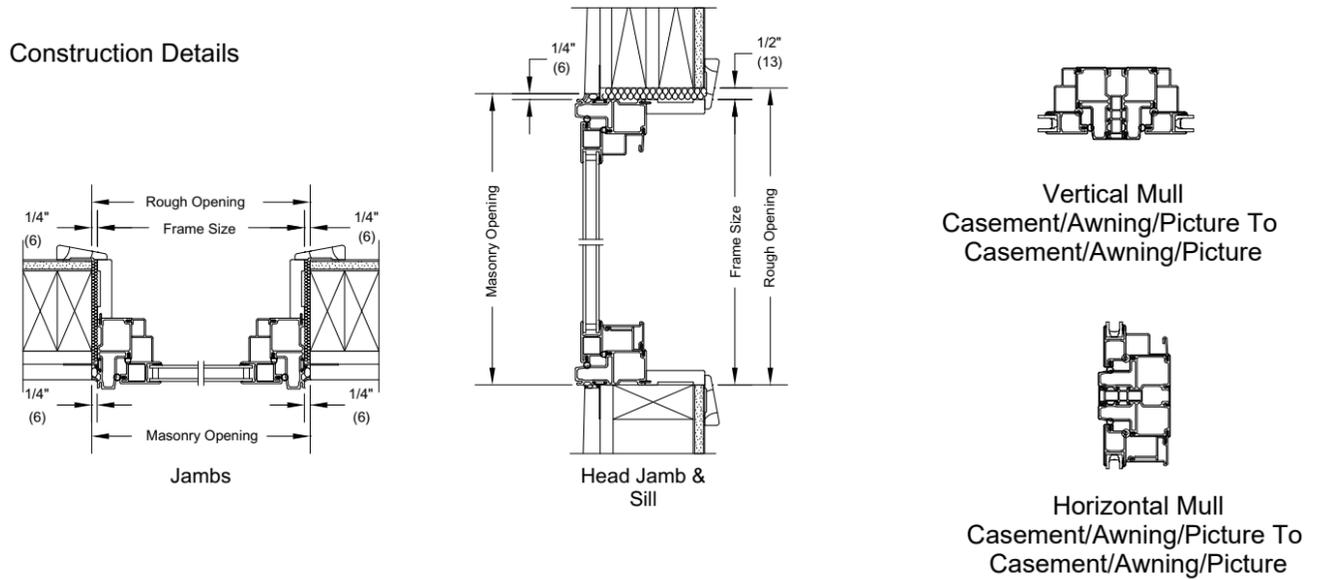

SINGLE HUNG

MO (mm)	1' - 6" (457)	2' - 0" (610)	2' - 6" (762)	2' - 8" (813)	3' - 0" (914)	3' - 6" (1067)	4' - 0" (1219)
RO (mm)	1' - 6" (457)	2' - 0" (610)	2' - 6" (762)	2' - 8" (813)	3' - 0" (914)	3' - 6" (1067)	4' - 0" (1219)
FS (mm)	1' - 5 1/2" (445)	1' - 11 1/2" (597)	2' - 5 1/2" (749)	2' - 7 1/2" (800)	2' - 11 1/2" (902)	3' - 5 1/2" (1054)	3' - 11 1/2" (1207)
DLO (mm)	12 9/16" (319)	18 9/16" (471)	24 9/16" (624)	26 9/16" (675)	30 9/16" (776)	36 9/16" (929)	42 9/16" (1081)

1' - 11 3/4" (603)							
2' - 5 3/4" (756)							
3' - 0" (914)							
3' - 5 3/4" (1060)							
4' - 0" (1219)							
4' - 5 3/4" (1365)							
5' - 0" (1524)							
5' - 5 3/4" (1670)							
6' - 0" (1829)							
6' - 5 3/4" (1975)							

SINGLE HUNG

2 Wide

MO (mm)	3' - 0" (914)	4' - 0" (1219)	5' - 0" (1524)	5' - 4" (1626)	6' - 0" (1829)	7' - 0" (2134)	8' - 0" (2438)
RO (mm)	3' - 0" (914)	4' - 0" (1219)	5' - 0" (1524)	5' - 4" (1626)	6' - 0" (1829)	7' - 0" (2134)	8' - 0" (2438)
FS (mm)	2' - 11 1/2" (902)	3' - 11 1/2" (1207)	4' - 11 1/2" (1511)	5' - 3 1/2" (1613)	5' - 11 1/2" (1816)	6' - 11 1/2" (2121)	7' - 11 1/2" (2426)

1' - 11 3/4" (603)							
2' - 5 3/4" (756)							
3' - 0" (914)							
3' - 5 3/4" (1060)							
4' - 0" (1219)							
4' - 5 3/4" (1365)							
5' - 0" (1524)							
5' - 5 3/4" (1670)							
6' - 0" (1829)							
6' - 5 3/4" (1975)							

SINGLE HUNG

3 Wide

MO (mm)	4' - 6" (1372)	6' - 0" (1829)	7' - 6" (2286)	8' - 0" (2438)	9' - 0" (2743)
RO (mm)	4' - 6" (1372)	6' - 0" (1829)	7' - 6" (2286)	8' - 0" (2438)	9' - 0" (2743)
FS (mm)	4' - 5 1/2" (1359)	5' - 11 1/2" (1816)	7' - 5 1/2" (2273)	7' - 11 1/2" (2426)	8' - 11 1/2" (2731)

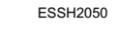
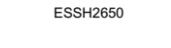
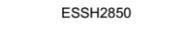
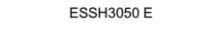
1' - 11 3/4" (603) 2' - 0" (610) 1' - 11 1/2" (697)					
ESSH1620	ESSH2020	ESSH2620	ESSH2820	ESSH3020	
2' - 5 3/4" (756) 2' - 6" (762) 2' - 5 1/2" (749)					
ESSH1626	ESSH2026	ESSH2626	ESSH2826	ESSH3026	
2' - 11 3/4" (908) 3' - 0" (914) 2' - 11 1/2" (902)					
ESSH1630	ESSH2030	ESSH2630	ESSH2830	ESSH3030	
3' - 5 3/4" (1060) 3' - 6" (1067) 3' - 5 1/2" (1054)					
ESSH1636	ESSH2036	ESSH2636	ESSH2836	ESSH3036	
3' - 11 3/4" (1213) 4' - 0" (1219) 3' - 11 1/2" (1207)					
ESSH1640	ESSH2040	ESSH2640	ESSH2840	ESSH3040	
4' - 5 3/4" (1365) 4' - 6" (1372) 4' - 5 1/2" (1359)					
ESSH1646	ESSH2046	ESSH2646	ESSH2846	ESSH3046	
4' - 11 3/4" (1518) 5' - 0" (1524) 4' - 11 1/2" (1511)					
ESSH1650	ESSH2050	ESSH2650	ESSH2850	ESSH3050 E	
5' - 5 3/4" (1670) 5' - 6" (1676) 5' - 5 1/2" (1664)					
ESSH1656	ESSH2056	ESSH2656	ESSH2856	ESSH3056 E	
5' - 11 3/4" (1822) 6' - 0" (1829) 5' - 11 1/2" (1816)					
ESSH1660	ESSH2060	ESSH2660 E	ESSH2860 E	ESSH3060 E	
6' - 5 3/4" (1975) 6' - 6" (1981) 6' - 5 1/2" (1969)					
ESSH1666	ESSH2066	ESSH2666 E	ESSH2866 E	ESSH3066 E	

SINGLE HUNG

4 Wide

MO (mm)	6' - 0" (1829)	8' - 0" (2438)
RO (mm)	6' - 0" (1829)	8' - 0" (2438)
FS (mm)	5' - 11 1/2" (1816)	7' - 11 1/2" (2426)

1' - 11 3/4" (603) 2' - 0" (610) 1' - 11 1/2" (697)		
ESSH1620	ESSH2020	
2' - 5 3/4" (756) 2' - 6" (762) 2' - 5 1/2" (749)		
ESSH1626	ESSH2026	
2' - 11 3/4" (908) 3' - 0" (914) 2' - 11 1/2" (902)		
ESSH1630	ESSH2030	
3' - 5 3/4" (1060) 3' - 6" (1067) 3' - 5 1/2" (1054)		
ESSH1636	ESSH2036	
3' - 11 3/4" (1213) 4' - 0" (1219) 3' - 11 1/2" (1207)		
ESSH1640	ESSH2040	
4' - 5 3/4" (1365) 4' - 6" (1372) 4' - 5 1/2" (1359)		
ESSH1646	ESSH2046	
4' - 11 3/4" (1518) 5' - 0" (1524) 4' - 11 1/2" (1511)		
ESSH1650	ESSH2050	
5' - 5 3/4" (1670) 5' - 6" (1676) 5' - 5 1/2" (1664)		
ESSH1656	ESSH2056	
5' - 11 3/4" (1822) 6' - 0" (1829) 5' - 11 1/2" (1816)		
ESSH1660	ESSH2060	
6' - 5 3/4" (1975) 6' - 6" (1981) 6' - 5 1/2" (1969)		
ESSH1666	ESSH2066	

GBG available in standard Rectangular lite cut, shown. Other GBG lite cuts shown on page 3.

E = These windows (in equal sash) meet National Egress Codes for fire evacuation. Local codes may differ.

Details and Elevations not to scale.

Available in equal, cottage, and reverse cottage sash configurations. Cottage and reverse cottage sash configurations are not available on 20 call number heights.

Units may optionally include a window opening control tested to ASTM F2090-10, which can be released from the inside without the use of a key, tool, special knowledge, or force greater than that required for normal unit operation.

Special sized units available within product size matrix. See your Marvin retailer.

See page 56 for specific PG Ratings.

For further details and drawings visit the 'Technical Specifications' section at Marvin.com.

SINGLE HUNG - TRANSOMS AND MULTIPLE ASSEMBLIES

Transom Mullered Over Single Hung

MO (mm)	2' - 6" (762)
RO (mm)	2' - 6" (762)
FS (mm)	2' - 5 1/2" (749)



Transom Mullered Over Single Hung 2 Wide

MO (mm)	5' - 0" (1524)
RO (mm)	5' - 0" (1524)
FS (mm)	4' - 11 1/2" (1511)



Single Hung Flankers with Center Picture*

MO (mm)	10' - 0" (3048)
RO (mm)	10' - 0" (3048)
FS (mm)	9' - 11 1/2" (3035)

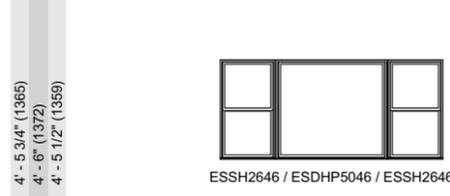

Single Hung Flankers with Center Operator

MO (mm)	7' - 6" (2286)
RO (mm)	7' - 6" (2286)
FS (mm)	7' - 5 1/2" (2273)

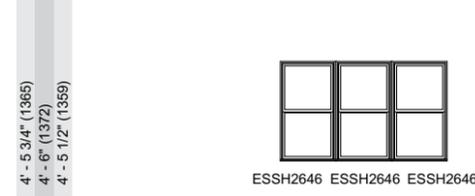

Construction Details

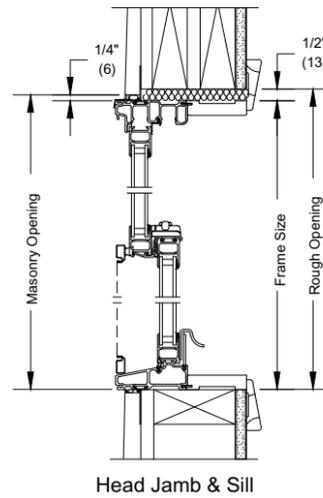
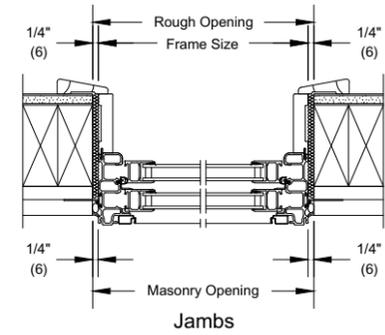

Vertical Mull
Double Hung To Single Hung

Horizontal Mull
Picture/Transom To Double Hung

MULLED ASSEMBLIES

Units can be factory mulled.
 MAXIMUM ROUGH OPENING not to exceed 114" x 78". Maximum up to 6 units wide by 1 unit high.
 MAXIMUM ROUGH OPENING not to exceed 60" x 96". Maximum up to 1 unit wide by 5 units high.
 For Multi-Wide Multi-High assemblies, MAXIMUM ROUGH OPENING not to exceed 96" x 96". Maximum up to 5 units wide by 5 units high.
 Field mull kits are available. Structural mullion reinforcement is required for some assemblies.
 Please consult your local Marvin representative for more information.

E = These windows (in equal sash) meet National Egress Codes for fire evacuation. Local codes may differ.

* This product is only available field mulled.

Details and Elevations not to scale.

Available in equal, cottage, and reverse cottage sash configurations. Cottage and reverse cottage sash configurations are not available on 20 and 66 call number heights.

Units may optionally include a window opening control device tested to ASTM F2090-10, which can be released from the inside without the use of a key, tool, special knowledge, or force greater than that required for normal unit operation.

Special sized units available within product size matrix. See your Marvin retailer.

See page 56 for specific PG Ratings.

DOUBLE HUNG

MO (mm)	1' - 6" (457)	2' - 0" (610)	2' - 6" (762)	2' - 8" (813)	3' - 0" (914)	3' - 6" (1067)	4' - 0" (1219)
RO (mm)	1' - 6" (457)	2' - 0" (610)	2' - 6" (762)	2' - 8" (813)	3' - 0" (914)	3' - 6" (1067)	4' - 0" (1219)
FS (mm)	1' - 5 1/2" (445)	1' - 11 1/2" (597)	2' - 5 1/2" (749)	2' - 7 1/2" (800)	2' - 11 1/2" (902)	3' - 5 1/2" (1054)	3' - 11 1/2" (1207)
DLO (mm)	12 9/16" (319)	18 9/16" (471)	24 9/16" (624)	26 9/16" (675)	30 9/16" (776)	36 9/16" (929)	42 9/16" (1081)

5' - 11 3/4" (1822) 6' - 0" (1829) 5' - 11 1/2" (1816)	ESDH1620	ESDH2020	ESDH2620	ESDH2820	ESDH3020	ESDH3620	ESDH4020
2' - 5 3/4" (756) 2' - 6" (762) 2' - 5 1/2" (749) 11 5/16" (287) 8 5/16" (211)	ESDH1626	ESDH2026	ESDH2626	ESDH2826	ESDH3026	ESDH3626	ESDH4026
2' - 11 3/4" (908) 3' - 0" (914) 2' - 11 1/2" (902) 14 5/16" (363)	ESDH1630	ESDH2030	ESDH2630	ESDH2830	ESDH3030	ESDH3630	ESDH4030
3' - 5 3/4" (1060) 3' - 6" (1067) 3' - 5 1/2" (1054) 17 5/16" (440)	ESDH1636	ESDH2036	ESDH2636	ESDH2836	ESDH3036	ESDH3636	ESDH4036
3' - 11 3/4" (1213) 4' - 0" (1219) 3' - 11 1/2" (1207) 20 5/16" (516)	ESDH1640	ESDH2040	ESDH2640	ESDH2840	ESDH3040	ESDH3640	ESDH4040
4' - 5 3/4" (1365) 4' - 6" (1372) 4' - 5 1/2" (1359) 23 5/16" (592)	ESDH1646	ESDH2046	ESDH2646	ESDH2846	ESDH3046	ESDH3646	ESDH4046
4' - 11 3/4" (1518) 5' - 0" (1524) 4' - 11 1/2" (1511) 26 5/16" (668)	ESDH1650	ESDH2050	ESDH2650	ESDH2850	ESDH3050 E	ESDH3650 E	ESDH4050 E
5' - 5 3/4" (1670) 5' - 6" (1676) 5' - 5 1/2" (1664) 29 5/16" (744)	ESDH1656	ESDH2056	ESDH2656	ESDH2856	ESDH3056 E	ESDH3656 E	ESDH4056 E
5' - 11 3/4" (1822) 6' - 0" (1829) 5' - 11 1/2" (1816) 32 5/16" (821)	ESDH1660	ESDH2060	ESDH2660 E	ESDH2860 E	ESDH3060 E	ESDH3660 E	ESDH4060 E
6' - 5 3/4" (1975) 6' - 6" (1981) 6' - 5 1/2" (1969) 35 5/16" (897)	ESDH1666	ESDH2066	ESDH2666 E	ESDH2866 E	ESDH3066 E	ESDH3666 E	ESDH4066 E

DOUBLE HUNG

2 Wide

MO (mm)	3' - 0" (914)	4' - 0" (1219)	5' - 0" (1524)	5' - 4" (1626)	6' - 0" (1829)	7' - 0" (2134)	8' - 0" (2438)
RO (mm)	3' - 0" (914)	4' - 0" (1219)	5' - 0" (1524)	5' - 4" (1626)	6' - 0" (1829)	7' - 0" (2134)	8' - 0" (2438)
FS (mm)	2' - 11 1/2" (902)	3' - 11 1/2" (1207)	4' - 11 1/2" (1511)	5' - 3 1/2" (1600)	5' - 11 1/2" (1816)	6' - 11 1/2" (2121)	7' - 11 1/2" (2426)

1' - 11 3/4" (603) 2' - 0" (610) 1' - 11 1/2" (597)	 ESDH1620	 ESDH2020	 ESDH2620	 ESDH2820	 ESDH3020	 ESDH3620	 ESDH4020
2' - 5 3/4" (756) 2' - 6" (762) 2' - 5 1/2" (749)	 ESDH1626	 ESDH2026	 ESDH2626	 ESDH2826	 ESDH3026	 ESDH3626	 ESDH4026
2' - 11 3/4" (908) 3' - 0" (914) 2' - 11 1/2" (902)	 ESDH1630	 ESDH2030	 ESDH2630	 ESDH2830	 ESDH3030	 ESDH3630	 ESDH4030
3' - 5 3/4" (1060) 3' - 6" (1067) 3' - 5 1/2" (1054)	 ESDH1636	 ESDH2036	 ESDH2636	 ESDH2836	 ESDH3036	 ESDH3636	 ESDH4036
3' - 11 3/4" (1213) 4' - 0" (1219) 3' - 11 1/2" (1207)	 ESDH1640	 ESDH2040	 ESDH2640	 ESDH2840	 ESDH3040	 ESDH3640	 ESDH4040
4' - 5 3/4" (1365) 4' - 6" (1372) 4' - 5 1/2" (1359)	 ESDH1646	 ESDH2046	 ESDH2646	 ESDH2846	 ESDH3046	 ESDH3646	 ESDH4046
4' - 11 3/4" (1518) 5' - 0" (1524) 4' - 11 1/2" (1511)	 ESDH1650	 ESDH2050	 ESDH2650	 ESDH2850	 ESDH3050 E	 ESDH3650 E	 ESDH4050 E
5' - 5 3/4" (1670) 5' - 6" (1676) 5' - 5 1/2" (1664)	 ESDH1656	 ESDH2056	 ESDH2656	 ESDH2856	 ESDH3056 E	 ESDH3656 E	 ESDH4056 E
5' - 11 3/4" (1822) 6' - 0" (1829) 5' - 11 1/2" (1816)	 ESDH1660	 ESDH2060	 ESDH2660 E	 ESDH2860 E	 ESDH3060 E	 ESDH3660 E	 ESDH4060 E
6' - 5 3/4" (1975) 6' - 6" (1981) 6' - 5 1/2" (1969)	 ESDH1666	 ESDH2066	 ESDH2666 E	 ESDH2866 E	 ESDH3066 E	 ESDH3666 E	 ESDH4066 E

DOUBLE HUNG

3 Wide

MO (mm)	4' - 6" (1372)	6' - 0" (1829)	7' - 6" (2286)	8' - 0" (2438)	9' - 0" (2743)
RO (mm)	4' - 6" (1372)	6' - 0" (1829)	7' - 6" (2286)	8' - 0" (2438)	9' - 0" (2743)
FS (mm)	4' - 5 1/2" (1359)	5' - 11 1/2" (1816)	7' - 5 1/2" (2273)	7' 11 1/2" (2413)	8' - 11 1/2" (2731)

1' - 11 3/4" (603) 2' - 0" (610) 1' - 11 1/2" (597)	 ESDH1620	 ESDH2020	 ESDH2620	 ESDH2820	 ESDH3026
2' - 5 3/4" (756) 2' - 6" (762) 2' - 5 1/2" (749)	 ESDH1626	 ESDH2026	 ESDH2626	 ESDH2826	 ESDH3026
2' - 11 3/4" (908) 3' - 0" (914) 2' - 11 1/2" (902)	 ESDH1630	 ESDH2030	 ESDH2630	 ESDH2830	 ESDH3030
3' - 5 3/4" (1060) 3' - 6" (1067) 3' - 5 1/2" (1054)	 ESDH1636	 ESDH2036	 ESDH2636	 ESDH2836	 ESDH3036
3' - 11 3/4" (1213) 4' - 0" (1219) 3' - 11 1/2" (1207)	 ESDH1640	 ESDH2040	 ESDH2640	 ESDH2840	 ESDH3040
4' - 5 3/4" (1365) 4' - 6" (1372) 4' - 5 1/2" (1359)	 ESDH1646	 ESDH2046	 ESDH2646	 ESDH2846	 ESDH3046
4' - 11 3/4" (1518) 5' - 0" (1524) 4' - 11 1/2" (1511)	 ESDH1650	 ESDH2050	 ESDH2650	 ESDH2850	 ESDH3050 E
5' - 5 3/4" (1670) 5' - 6" (1676) 5' - 5 1/2" (1664)	 ESDH1656	 ESDH2056	 ESDH2656	 ESDH2856	 ESDH3056 E
5' - 11 3/4" (1822) 6' - 0" (1829) 5' - 11 1/2" (1816)	 ESDH1660	 ESDH2060	 ESDH2660 E	 ESDH2860 E	 ESDH3060 E
6' - 5 3/4" (1975) 6' - 6" (1981) 6' - 5 1/2" (1969)	 ESDH1666	 ESDH2066	 ESDH2666 E	 ESDH2866 E	 ESDH3066 E

DOUBLE HUNG

4 Wide

MO (mm)	6' - 0" (1829)	8' - 0" (2438)
RO (mm)	6' - 0" (1829)	8' - 0" (2438)
FS (mm)	5' - 11 1/2" (1816)	7' - 11 1/2" (2426)

1' - 11 3/4" (603)		
2' - 5 3/4" (756)		
2' - 11 3/4" (908)		
3' - 5 3/4" (1060)		
3' - 11 3/4" (1213)		
4' - 5 3/4" (1365)		
4' - 11 3/4" (1518)		
5' - 5 3/4" (1670)		
5' - 11 3/4" (1822)		
6' - 5 3/4" (1975)		

GBG available in standard Rectangular lite cut, shown. Other GBG lite cuts shown on page 3.

E = These windows (in equal sash) meet National Egress Codes for fire evacuation. Local codes may differ.

Details and Elevations not to scale.

Available in equal, cottage, and reverse cottage sash configurations. Cottage and reverse cottage sash configurations are not available on 20, 60, and 66 call number heights.

Units may optionally include a window opening control device tested to ASTM F2090-10, which can be released from the inside without the use of a key, tool, special knowledge, or force greater than that required for normal unit operation.

Special sized units available within product size matrix. See your Marvin retailer.

See page 56 for specific PG Ratings.

For further details and drawings visit the "Technical Specifications" section at Marvin.com.

DOUBLE HUNG - TRANSOMS AND MULTIPLE ASSEMBLIES

Transom Muller Over Double Hung

MO (mm)	2' - 6" (762)
RO (mm)	2' - 6" (762)
FS (mm)	2' - 5 1/2" (749)

5' - 11 3/4" (1822)	
6' - 0" (1829)	
5' - 11 1/2" (1816)	

Transom Muller Over Double Hung 2 Wide

MO (mm)	5' - 0" (1524)
RO (mm)	5' - 0" (1524)
FS (mm)	4' - 11 1/2" (1511)

5' - 11 3/4" (1822)	
6' - 0" (1829)	
5' - 11 1/2" (1816)	

Double Hung Flankers with Center Picture*

MO (mm)	10' - 0" (3048)
RO (mm)	10' - 0" (3048)
FS (mm)	9' - 11 1/2" (3035)

4' - 5 3/4" (1365)	
4' - 6" (1372)	
4' - 5 1/2" (1359)	

Double Hung Flankers with Center Operator

MO (mm)	7' - 6" (2286)
RO (mm)	7' - 6" (2286)
FS (mm)	7' - 5 1/2" (2273)

4' - 5 3/4" (1365)	
4' - 6" (1372)	
4' - 5 1/2" (1359)	

Construction Details

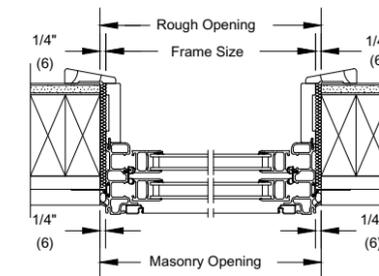

Jamb

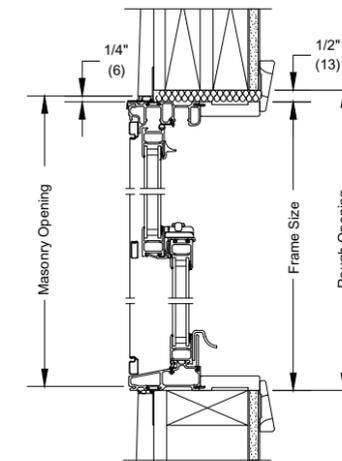

Head Jamb & Sill

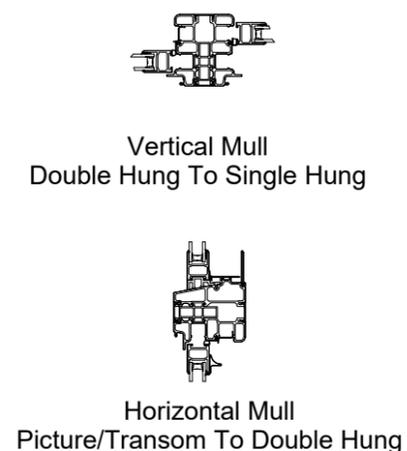

Vertical Mull
Double Hung To Single Hung

Horizontal Mull
Picture/Transom To Double Hung

* This product is only available field muller.

Details and Elevations not to scale.

Available in equal, cottage, and reverse cottage sash configurations. Cottage and reverse cottage sash configurations are not available on 20, 60, and 66 call number heights.

Special sized units available within product size matrix. See your Marvin retailer.

Units may optionally include a window opening control device tested to ASTM F2090-10, which can be released from the inside without the use of a key, tool, special knowledge, or force greater than that required for normal unit operation.

See page 56 for specific PG Ratings.

For further details and drawings visit the "Technical Specifications" section at Marvin.com.

MULLED ASSEMBLIES

Mulling can be factory muller.

MAXIMUM ROUGH OPENING not to exceed 114" x 78". Maximum up to 6 units wide by 1 unit high.

MAXIMUM ROUGH OPENING not to exceed 60" x 96". Maximum up to 1 unit wide by 5 units high.

For Multi-Wide Multi-High assemblies, MAXIMUM ROUGH OPENING not to exceed 96" x 96". Maximum up to 5 units wide by 5 units high.

Field mull kits are available. Structural mullion reinforcement is required for some assemblies.

Please consult your local Marvin representative for more information.

GLIDER

MO (mm)	2'-6" (762)	3'-0" (914)	3'-6" (1067)	4'-0" (1219)	4'-6" (1372)	5'-0" (1524)	6'-0" (1829)
RO (mm)	2'-6" (762)	3'-0" (914)	3'-6" (1067)	4'-0" (1219)	4'-6" (1372)	5'-0" (1524)	6'-0" (1829)
FS (mm)	2'-5 1/2" (749)	2'-11 1/2" (902)	3'-5 1/2" (1054)	3'-11 1/2" (1207)	4'-5 1/2" (1359)	4'-11 1/2" (1511)	5'-11 1/2" (1816)
DLO (mm)	11 5/16" (287)	14 5/16" (363)	17 5/16" (440)	20 5/16" (516)	23 5/16" (592)	26 5/16" (668)	32 5/16" (821)

1'-5 3/4" (451)							
1'-6" (457)							
1'-11 3/4" (603)							
2'-0" (610)							
2'-5 3/4" (756)							
2'-6" (762)							
2'-11 1/2" (902)							
2'-11 3/4" (908)							
3'-0" (914)							
3'-5 3/4" (1060)							
3'-6" (1067)							
3'-11 1/2" (1207)							
3'-11 3/4" (1213)							
4'-0" (1219)							
4'-5 3/4" (1365)							
4'-6" (1372)							
4'-11 1/2" (1511)							
4'-11 3/4" (1518)							
5'-0" (1524)							
54 9/16" (1386)							

GBG available in standard Rectangular lite cut, shown. Other GBG lite cuts shown on page 3.

E = These windows meet National Egress Codes for fire evacuation. Local codes may differ.

Details and Elevations not to scale.

XO operation standard, OX operation optional.

Units may optionally include a window opening control device tested to ASTM F2090-10, which can be released from the inside without the use of a key, tool, special knowledge, or force greater than that required for normal unit operation.

Special sized units available within product size matrix. See your Marvin retailer.

See page 56 for specific PG Ratings.

For further details and drawings visit the 'Technical Specifications' section at Marvin.com.

GLIDER TRIPLE SASH

MO (mm)	6'-0" (1829)	7'-0" (2134)	8'-0" (2438)
RO (mm)	6'-0" (1829)	7'-0" (2134)	8'-0" (2438)
FS (mm)	5'-11 1/2" (1816)	6'-11 1/2" (2121)	7'-11 1/2" (2426)

1'-5 3/4" (451)			
1'-6" (457)			
1'-11 3/4" (603)			
2'-0" (610)			
2'-5 3/4" (756)			
2'-6" (762)			
2'-11 1/2" (902)			
2'-11 3/4" (908)			
3'-0" (914)			
3'-5 3/4" (1060)			
3'-6" (1067)			
3'-11 1/2" (1207)			
3'-11 3/4" (1213)			
4'-0" (1219)			
4'-5 3/4" (1365)			
4'-6" (1372)			
4'-11 1/2" (1511)			
4'-11 3/4" (1518)			
5'-0" (1524)			

GBG available in standard Rectangular lite cut, shown. Other GBG lite cuts shown on page 3.

E = These windows meet National Egress Codes for fire evacuation. Local codes may differ.

Details and Elevations not to scale.

Units may optionally include a window opening control device tested to ASTM F2090-10, which can be released from the inside without the use of a key, tool, special knowledge, or force greater than that required for normal unit operation.

Special sized units available within product size matrix. See your Marvin retailer.

See page 56 for specific PG Ratings.

For further details and drawings visit the 'Technical Specifications' section at Marvin.com.

MULTIPLE ASSEMBLIES

Field mull kits are available. Structural mullion reinforcement is required for some assemblies.

Please consult your local Marvin representative for more information.

Construction Details

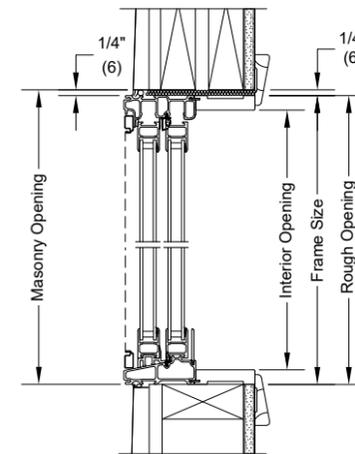

Head Jamb & Sill

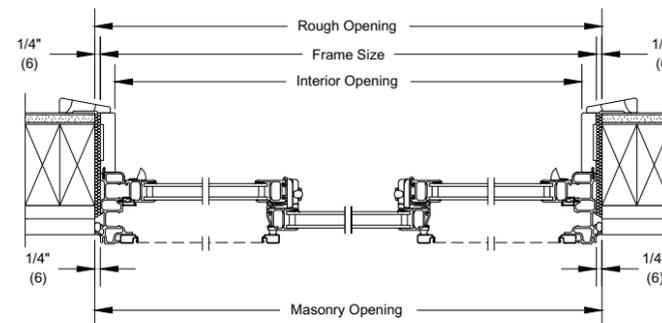

Triple Sash XO Operator Jamb

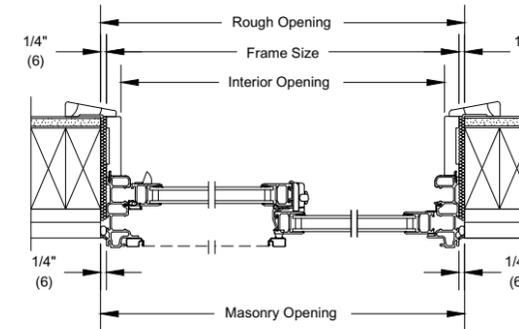

XO Operator Jamb

GLIDER

2 Wide

MO (mm)	5' - 0" (1524)	6' - 0" (1828)	7' - 0" (2134)	8' - 0" (2438)	9' - 0" (2744)
RO (mm)	5' - 0" (1524)	6' - 0" (1828)	7' - 0" (2134)	8' - 0" (2438)	9' - 0" (2744)
FS (mm)	4' - 11 1/2" (1511)	5' - 11 1/2" (1816)	6' - 11 1/2" (2121)	7' - 11 1/2" (2426)	8' - 11 1/2" (2734)

1' - 5 3/4" (451)					
1' - 6" (457)					
1' - 5 1/2" (445)					
1' - 11 3/4" (603)					
2' - 0" (610)					
2' - 6" (762)					
2' - 5 3/4" (756)					
2' - 11 3/4" (908)					
3' - 0" (914)					
3' - 6" (1067)					
3' - 5 1/2" (1054)					
3' - 11 3/4" (1213)					
4' - 0" (1219)					
4' - 6" (1372)					
4' - 5 3/4" (1365)					
4' - 11 3/4" (1518)					
5' - 0" (1524)					
5' - 11 1/2" (1816)					
6' - 0" (1828)					

MULLED ASSEMBLIES

Mulling can be factory mulled.

MAXIMUM ROUGH OPENING not to exceed 114" x 60". Maximum up to 3 units wide by 1 unit high.

MAXIMUM ROUGH OPENING not to exceed 72" x 96". Maximum up to 1 unit wide by 2 units high.

For Multi-Wide Multi-High assemblies, **MAXIMUM ROUGH OPENING** not to exceed 96" x 96". Maximum up to 2 units wide by 2 units high.

Field mull kits are available. Structural mullion reinforcement is required for some assemblies.

Please consult your local Marvin representative for more information.

Construction Details

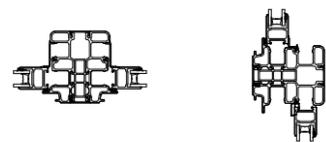

Vertical Mull
Glider to Glider

Horizontal Mull
Glider to Glider

DOUBLE HUNG PICTURE

MO (mm)	1' - 6" (457)	2' - 0" (610)	2' - 6" (762)	2' - 8" (813)	3' - 0" (914)	3' - 6" (1067)	4' - 0" (1219)	5' - 0" (1524)
RO (mm)	1' - 6" (457)	2' - 0" (610)	2' - 6" (762)	2' - 8" (813)	3' - 0" (914)	3' - 6" (1067)	4' - 0" (1219)	5' - 0" (1524)
FS (mm)	1' - 5 1/2" (445)	1' - 11 1/2" (597)	2' - 5 1/2" (749)	2' - 7 1/2" (800)	2' - 11 1/2" (902)	3' - 5 1/2" (1054)	3' - 11 1/2" (1207)	4' - 11 1/2" (1511)
DLO (mm)	12 9/16" (319)	18 9/16" (471)	24 9/16" (624)	26 9/16" (675)	30 9/16" (776)	36 9/16" (929)	42 9/16" (1081)	54 9/16" (1386)

1' - 11 3/4" (603)								
2' - 0" (610)								
2' - 6" (762)								
2' - 5 3/4" (756)								
2' - 11 3/4" (908)								
3' - 0" (914)								
3' - 6" (1067)								
3' - 5 1/2" (1054)								
3' - 11 3/4" (1213)								
4' - 0" (1219)								
4' - 6" (1372)								
4' - 5 3/4" (1365)								
4' - 11 3/4" (1518)								
5' - 0" (1524)								
5' - 11 1/2" (1816)								
6' - 0" (1828)								

MO (mm)	1' - 6" (457)	2' - 0" (610)	2' - 6" (762)	2' - 8" (813)	3' - 0" (914)	3' - 6" (1067)	4' - 0" (1219)	5' - 0" (1524)
RO (mm)	1' - 6" (457)	2' - 0" (610)	2' - 6" (762)	2' - 8" (813)	3' - 0" (914)	3' - 6" (1067)	4' - 0" (1219)	5' - 0" (1524)
FS (mm)	1' - 5 1/2" (445)	1' - 11 1/2" (597)	2' - 5 1/2" (749)	2' - 7 1/2" (800)	2' - 11 1/2" (902)	3' - 5 1/2" (1054)	3' - 11 1/2" (1207)	4' - 11 1/2" (1511)
DLO (mm)	12 9/16" (319)	18 9/16" (471)	24 9/16" (624)	26 9/16" (675)	30 9/16" (776)	36 9/16" (929)	42 9/16" (1081)	54 9/16" (1386)

0' - 11 3/4" (298)								
1' - 5 3/4" (451)								
1' - 6" (457)								
1' - 5 1/2" (445)								
1' - 11 1/2" (597)								
18 9/16" (471)								

Construction Details

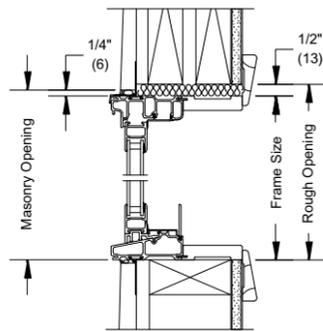

Head Jamb & Sill

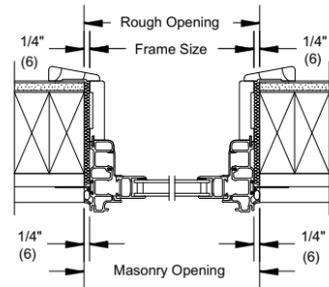

Jamb

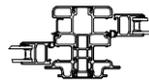

Vertical Mull
 Double Hung To Single Hung



Horizontal Mull
 Picture/Transom To Double Hung

GBG available in standard Rectangular lite cut, shown above. Other GBG lite cuts shown on page 3. (Not available on In-Sash Transom units.)

Details and Elevations not to scale.

Special sized units available within product size matrix. See your Marvin retailer.

See page 56 for specific PG Ratings.

For further details and drawings visit the 'Technical Specifications' section at Marvin.com.

MULLED ASSEMBLIES

Mulling can be factory mulled.

MAXIMUM ROUGH OPENING not to exceed 114" x 78". Maximum up to 6 units wide by 1 unit high.

MAXIMUM ROUGH OPENING not to exceed 60" x 96". Maximum up to 1 unit wide by 5 units high.

For Multi-Wide Multi-High assemblies, **MAXIMUM ROUGH OPENING** not to exceed 96" x 96". Maximum up to 5 units wide by 5 units high.

Field mull kits are available. Structural mullion reinforcement is required for some assemblies.

Please consult your local Marvin representative for more information.

DIRECT GLAZE ROUND TOPS

True Half Round (RT1)

MO (mm)	2' - 6" (762)	MO (mm)	2' - 8" (813)	MO (mm)	3' - 0" (914)	MO (mm)	3' - 6" (1067)
RO (mm)	2' - 6" (762)	RO (mm)	2' - 8" (813)	RO (mm)	3' - 0" (914)	RO (mm)	3' - 6" (1067)
FS (mm)	2' - 5 1/2" (749)	FS (mm)	2' - 7 1/2" (800)	FS (mm)	2' - 11 1/2" (902)	FS (mm)	3' - 5 1/2" (1054)
DLO (mm)	25 53/64" (656)	DLO (mm)	27 27/32" (707)	DLO (mm)	31 7/8" (810)	DLO (mm)	37 29/32" (963)

1' - 3" (381)		1' - 4" (406)		1' - 6" (457)		1' - 9" (533)	
1' - 3 1/4" (387)		1' - 4 1/4" (413)		1' - 6 1/4" (464)		1' - 9 1/4" (540)	
1' - 2 3/4" (451)		1' - 3 3/4" (400)		1' - 5 3/4" (451)		1' - 8 3/4" (527)	
11 5/16" (287)		12 5/16" (313)		14 5/16" (363)		17 5/16" (440)	
MO (mm)	4' - 0" (1219)	MO (mm)	5' - 0" (1524)	MO (mm)	5' - 4" (1626)	MO (mm)	5' - 4" (1626)
RO (mm)	4' - 0" (1219)	RO (mm)	5' - 0" (1524)	RO (mm)	5' - 4" (1626)	RO (mm)	5' - 4" (1626)
FS (mm)	3' - 11 1/2" (1207)	FS (mm)	4' - 11 1/2" (1511)	FS (mm)	4' - 11 1/2" (1511)	FS (mm)	5' - 3 1/2" (1613)
DLO (mm)	43 59/64" (1116)	DLO (mm)	55 61/64" (1421)	DLO (mm)	55 61/64" (1421)	DLO (mm)	59 61/64" (1523)
2' - 0" (610)		2' - 6" (762)		2' - 8" (813)		2' - 8" (813)	
2' - 0 1/4" (616)		2' - 6 1/4" (768)		2' - 8 1/4" (819)		2' - 8 1/4" (819)	
1' - 11 3/4" (603)		2' - 5 3/4" (756)		2' - 7 3/4" (806)		2' - 7 3/4" (806)	
20 5/16" (516)		26 5/16" (668)		28 5/16" (719)		28 5/16" (719)	
MO (mm)	6' - 0" (1829)	MO (mm)	7' - 0" (2134)	MO (mm)	8' - 0" (2438)	MO (mm)	8' - 0" (2438)
RO (mm)	6' - 0" (1829)	RO (mm)	7' - 0" (2134)	RO (mm)	8' - 0" (2438)	RO (mm)	8' - 0" (2438)
FS (mm)	5' - 11 1/2" (1816)	FS (mm)	6' - 11 1/2" (2121)	FS (mm)	6' - 11 1/2" (2121)	FS (mm)	7' - 11 1/2" (2426)
DLO (mm)	67 31/32" (1726)	DLO (mm)	79 63/64" (2032)	DLO (mm)	79 63/64" (2032)	DLO (mm)	92" (2337)
3' - 0" (914)		3' - 6" (1067)		4' - 0" (1219)		4' - 0" (1219)	
3' - 0 1/4" (921)		3' - 6 1/4" (1073)		4' - 0 1/4" (1226)		4' - 0 1/4" (1226)	
2' - 11 3/4" (908)		3' - 5 3/4" (1060)		3' - 11 3/4" (1213)		3' - 11 3/4" (1213)	
32 5/16" (821)		38 5/16" (973)		44 5/16" (1125)		44 5/16" (1125)	

Multiple Assemblies

MO (mm)	3' - 0" (914)
RO (mm)	3' - 0" (914)
FS (mm)	2' - 11 1/2" (902)

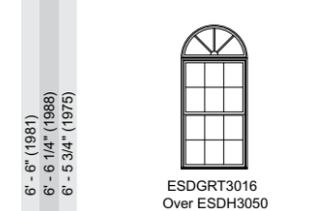

ESDGR3016
 Over ESDH3050

MO (mm)	5' - 0" (1524)
RO (mm)	5' - 0" (1524)
FS (mm)	4' - 11 1/2" (1511)



ESDGR5026
 Over ESCA2646

GBG only available in standard Round Top pattern, shown above.

Details and Elevations not to scale.

Sample multiples assemblies shown. Contact your Marvin representative for more information.

For further details and drawings visit the 'Technical Specifications' section at Marvin.com.

Construction Details

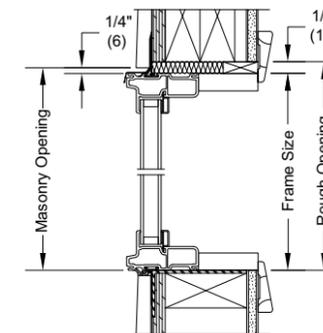

Head Jamb & Sill

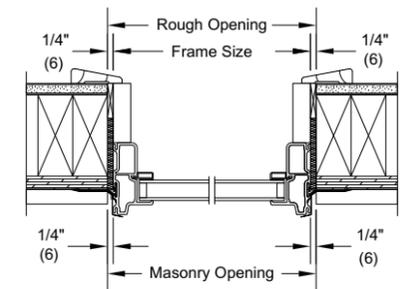

Jamb

MULLED ASSEMBLIES

MAXIMUM ROUGH OPENING - ESDG RT to ESCA, ESAWN, ESCA P, ESSH, ESDH, ESDH P, ESDG (Rectangle), ESDH TR, ESCA TR not to exceed 114" x 78" up to 6W1H.

MAXIMUM ROUGH OPENING - ESDG RT to ESGL not to exceed 96" x 96" up to 1 wide 5 high.

Both horizontal and vertical field mull kits are available. Structural mullion reinforcement is required for some assemblies.

Please consult your local Marvin representative for more information.

True Half Above Springline (RT2)

MO (mm)	2' - 6" (762)	2' - 8" (813)	3' - 0" (914)	3' - 6" (1067)
RO (mm)	2' - 6" (762)	2' - 8" (813)	3' - 0" (914)	3' - 6" (1067)
FS (mm)	2' - 5 1/2" (749)	2' - 7 1/2" (800)	2' - 11 1/2" (902)	3' - 5 1/2" (1054)
DLO (mm)	26 1/16" (662)	28 1/16" (713)	32 1/16" (814)	38 1/16" (967)
6' - 2 1/2" (1892)				
6' - 2 3/4" (1899)				
6' - 2 1/4" (1886)				
70 13/16" (1799)				
5' - 8 1/2" (1740)				
5' - 8 3/4" (1746)				
5' - 8 1/4" (1734)				
64 13/16" (1646)				
5' - 2 1/2" (1588)				
5' - 2 3/4" (1594)				
5' - 2 1/4" (1581)				
58 13/16" (1494)				
4' - 8 1/2" (1435)				
4' - 8 3/4" (1441)				
4' - 8 1/4" (1429)				
52 13/16" (1341)				
4' - 2 1/2" (1283)				
4' - 2 3/4" (1289)				
4' - 2 1/4" (1276)				
46 13/16" (1189)				
3' - 8 1/2" (1130)				
3' - 8 3/4" (1137)				
3' - 8 1/4" (1124)				
40 13/16" (1037)				
3' - 2 1/2" (978)				
3' - 2 3/4" (984)				
3' - 2 1/4" (972)				
34 13/16" (884)				
2' - 8 1/2" (826)				
2' - 8 3/4" (832)				
2' - 8 1/4" (819)				
28 13/16" (732)				
2' - 2 1/2" (673)				
2' - 2 3/4" (679)				
2' - 2 1/4" (667)				
22 13/16" (579)				

DIRECT GLAZE ROUND TOPS

True Half Above Springline (RT2)

MO (mm)	4' - 0" (1219)	5' - 0" (1524)	5' - 4" (1626)	6' - 0" (1829)
RO (mm)	4' - 0" (1219)	5' - 0" (1524)	5' - 4" (1626)	6' - 0" (1829)
FS (mm)	3' - 11 1/2" (1207)	4' - 11 1/2" (1511)	5' - 3 1/2" (1600)	5' - 11 1/2" (1816)
DLO (mm)	44 1/16" (1119)	56 1/16" (1424)	60 1/16" (1525)	68 1/16" (1729)
6' - 11 1/2" (2121)				
6' - 11 3/4" (2127)				
6' - 11 1/4" (2115)				
79 13/16" (2027)				
6' - 5 1/2" (1969)				
6' - 5 3/4" (1975)				
6' - 5 1/4" (1962)				
73 13/16" (1875)				
6' - 11 1/2" (2121)				
6' - 11 3/4" (2127)				
6' - 11 1/4" (2115)				
79 13/16" (2027)				
6' - 5 1/2" (1969)				
6' - 5 3/4" (1975)				
6' - 5 1/4" (1962)				
73 13/16" (1875)				
5' - 11 1/2" (1816)				
5' - 11 3/4" (1822)				
5' - 11 1/4" (1810)				
67 13/16" (1722)				
5' - 5 1/2" (1664)				
5' - 5 3/4" (1670)				
5' - 5 1/4" (1657)				
61 13/16" (1570)				
4' - 11 1/2" (1511)				
4' - 11 3/4" (1518)				
4' - 11 1/4" (1505)				
55 13/16" (1418)				
4' - 5 1/2" (1359)				
4' - 5 3/4" (1365)				
4' - 5 1/4" (1353)				
49 13/16" (1265)				
3' - 11 1/2" (1207)				
3' - 11 3/4" (1213)				
3' - 11 1/4" (1200)				
43 13/16" (1113)				
3' - 5 1/2" (1054)				
3' - 5 3/4" (1060)				
3' - 5 1/4" (1048)				
37 13/16" (960)				
2' - 11 1/2" (902)				
2' - 11 3/4" (908)				
2' - 11 1/4" (895)				
31 13/16" (808)				
5' - 1 1/2" (1867)				
6' - 1 3/4" (1873)				
6' - 1 1/4" (1861)				
75 13/16" (1926)				
6' - 7 1/2" (2019)				
6' - 7 3/4" (2026)				
6' - 7 1/4" (2013)				
75 13/16" (1926)				
5' - 1 1/2" (1867)				
6' - 1 3/4" (1873)				
6' - 1 1/4" (1861)				
69 13/16" (1773)				
5' - 7 1/2" (1715)				
6' - 7 3/4" (1721)				
6' - 7 1/4" (1708)				
63 13/16" (1621)				
5' - 1 1/2" (1562)				
6' - 1 3/4" (1568)				
6' - 1 1/4" (1556)				
57 13/16" (1468)				
4' - 7 1/2" (1410)				
4' - 7 3/4" (1416)				
4' - 7 1/4" (1403)				
51 13/16" (1316)				
4' - 5 1/2" (1359)				
4' - 5 3/4" (1365)				
4' - 5 1/4" (1353)				
49 13/16" (1265)				
3' - 7 1/2" (1105)				
3' - 7 3/4" (1111)				
3' - 7 1/4" (1099)				
39 13/16" (1011)				
4' - 5 1/2" (1359)				
4' - 5 3/4" (1365)				
4' - 5 1/4" (1353)				
49 13/16" (1265)				
4' - 11 1/2" (1511)				
4' - 11 3/4" (1518)				
4' - 11 1/4" (1505)				
55 13/16" (1418)				
5' - 1 1/2" (1867)				
6' - 1 3/4" (1873)				
6' - 1 1/4" (1861)				
69 13/16" (1773)				
5' - 5 1/2" (1664)				
6' - 5 3/4" (1670)				
6' - 5 1/4" (1657)				
61 13/16" (1570)				
4' - 11 1/2" (1511)				
4' - 11 3/4" (1518)				
4' - 11 1/4" (1505)				
55 13/16" (1418)				
5' - 5 1/2" (1664)				
6' - 5 3/4" (1670)				
6' - 5 1/4" (1657)				
61 13/16" (1570)				
5' - 11 1/2" (1816)				
6' - 11 3/4" (1822)				
6' - 11 1/4" (1810)				
67 13/16" (1722)				
6' - 7 1/2" (2019)				
6' - 7 3/4" (2026)				
6' - 7 1/4" (2013)				
75 13/16" (1926)				
6' - 11 1/2" (2121)				
6' - 11 3/4" (2127)				
6' - 11 1/4" (2115)				
79 13/16" (2027)				

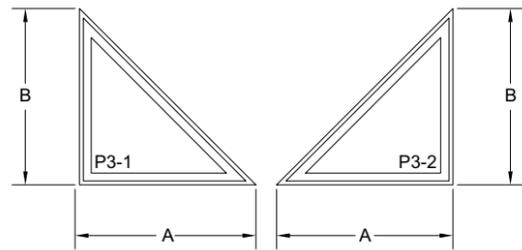

90° TRIANGLE

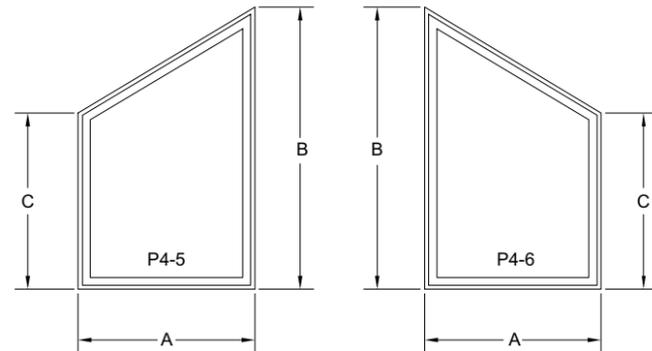

TRAPEZOID

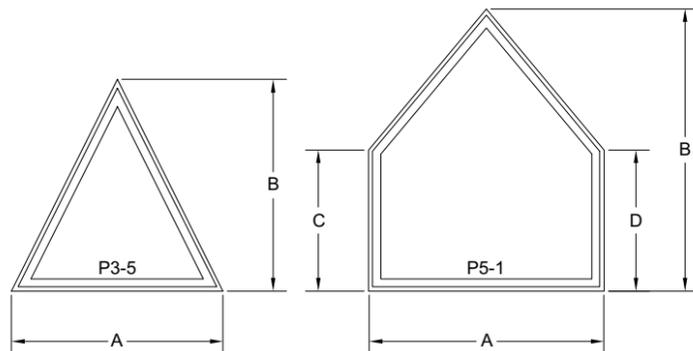

ISOSCELES TRIANGLE

PENTAGON

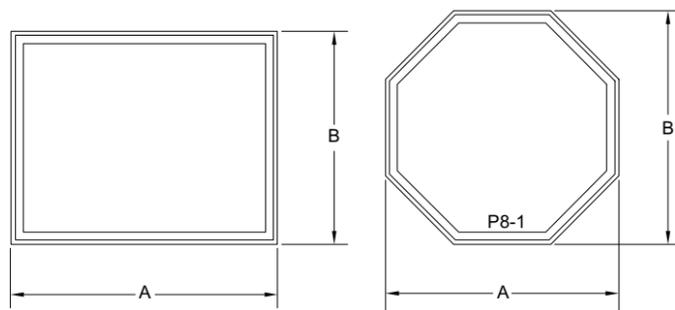

90° RECTANGLE

OCTAGON

HOW TO SPECIFY

When ordering a Trapezoid, Triangle, or Rectangle window, provide a sketch of the unit as viewed from the exterior, also include key Rough Opening dimensions.

EXAMPLE

To order a window of a Trapezoid opening provide the measurements of A, B, and C as indicated. For other shapes, give the dimensions shown.

SPECIFICATION NOTES

- All units are subject to validation.
- Maximum/Minimum Guidelines
- Maximum Square Footage: 49 ft² of Rough Opening
- Maximum Width: 114" Rough Opening
- Maximum Height: 114" Rough Opening
- Minimum (RECT, P3, P4, P5): 12" x 12" Rough Opening
- Minimum (P8): 18" x 18" Rough Opening
- Minimum Short Leg (P4, P5): 8" Rough Opening
- P3 Pitch: 3/12 to 36/12 Pitch Available
- P4 Pitch: 36/12 Maximum Pitch Available
- P5 Pitch: 36/12 Maximum Pitch Available

MULLED ASSEMBLIES

Mulled can be factory mulled. (Rectangle Only)
MAXIMUM ROUGH OPENING: not to exceed 114" x 96".
 Maximum up to 6 units wide by 1 unit high.
MAXIMUM ROUGH OPENING: not to exceed 96" x 96".
 Maximum up to 1 unit wide by 5 units high.
 NOTE: Units with Rough Opening larger than 37.75 ft² will be standard tempered.

Construction Details

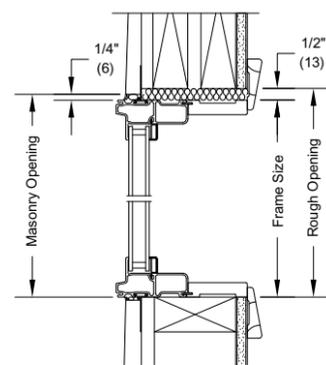

Head Jamb & Sill

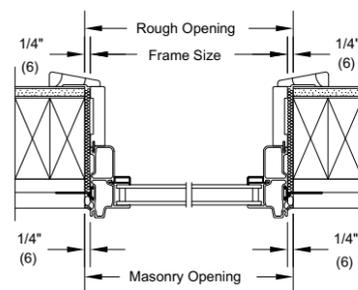

Jamb

SLIDING PATIO DOOR

2 Panel

MO (mm)	5' - 0" (1524)	5' - 0" (1524)	5' - 10 1/2" (1791)	5' - 10 1/2" (1791)	6' - 0" (1829)	6' - 0" (1829)
RO (mm)	5' - 0" (1524)	5' - 0" (1524)	5' - 10 1/2" (1791)	5' - 10 1/2" (1791)	6' - 0" (1829)	6' - 0" (1829)
FS (mm)	4' - 11 1/2" (1511)	4' - 11 1/2" (1511)	5' - 10" (1778)	5' - 10" (1778)	5' - 11 1/2" (1816)	5' - 11 1/2" (1816)
DLO (mm)	24 63/64" (635)	24 63/64" (635)	30 15/64" (768)	30 15/64" (768)	30 63/64" (787)	30 63/64" (787)

6' - 7 3/4" (2026) 6' - 8" (2032) 6' - 7 1/2" (2019) 72 1/2" (1841)						
6' - 9 3/4" (2076) 6' - 10" (2083) 6' - 9 1/2" (2070) 74 1/2" (1892)						
7' - 11 3/4" (2432) 8' - 0" (2438) 7' - 11 1/2" (2426) 88 1/2" (2248)						

CN Width	MO		RO		FS		DLO	
	in	mm	in	mm	in	mm	in	mm
CN80	8-0	(2438)	8-0	(2438)	7'-11 1/2"	(2426)	3'-6 63/64"	(1092)

MULLED ASSEMBLIES

Mulling units can be factory mulled up to 1 unit wide by 2 units high.
MAXIMUM ROUGH OPENING not to exceed 72" x 100".
 Field mull kits available for up to 3 units wide by 2 units high not to exceed 110" x 112". Not WDMA certified.
 Structural mullion reinforcement is required for some assemblies.
 Please consult your local Marvin representative for more information.

GBG available in standard Rectangular lite cut, shown above.
 Other GBG lite cuts shown on page 3. (Not available on In-Sash Transom units.)

Details and Elevations not to scale.

Special sized units available within two panel product size matrix.
 See your Marvin representative for more information.

See page 56 for specific PG Ratings.

For further details and drawings visit the 'Technical Specifications' section at Marvin.com.

3 Panel

MO (mm)	9' - 0" (2743)	9' - 0" (2743)	9' - 0" (2743)	9' - 0" (2743)
RO (mm)	9' - 0" (2743)	9' - 0" (2743)	9' - 0" (2743)	9' - 0" (2743)
FS (mm)	8' - 11 1/2" (2731)	8' - 11 1/2" (2731)	8' - 11 1/2" (2731)	8' - 11 1/2" (2731)
DLO (mm)	30 63/64" (787)	30 63/64" (787)	30 63/64" (787)	30 63/64" (787)

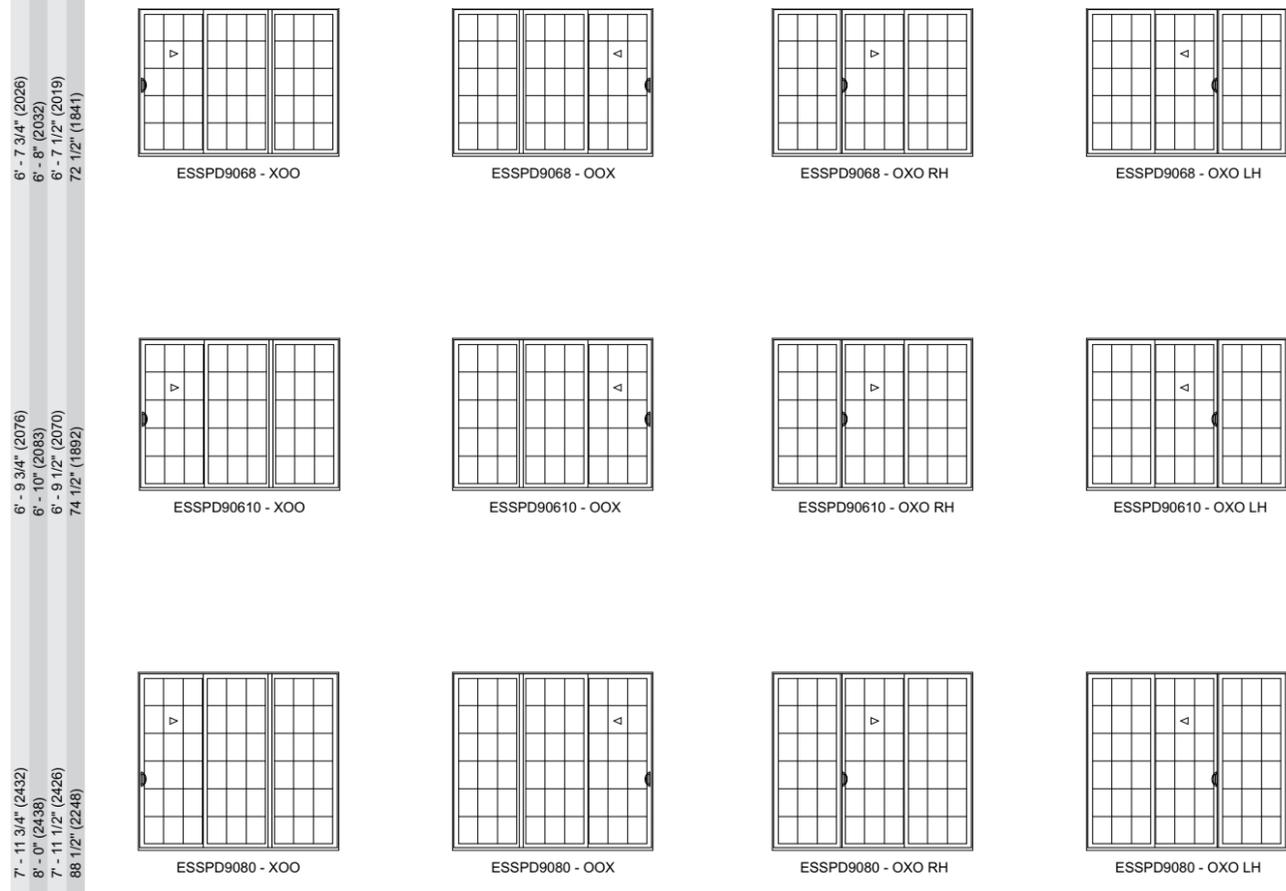

Direct Glaze Over Sliding Patio Door

MO (mm)	5' - 0" (1524)	5' - 10 1/2" (1791)	6' - 0" (1829)	9' - 0" (2743)
RO (mm)	5' - 0" (1524)	5' - 10 1/2" (1791)	6' - 0" (1829)	9' - 0" (2743)
FS (mm)	4' - 11 1/2" (1511)	5' - 10" (1778)	5' - 11 1/2" (1816)	8' - 11 1/2" (2731)
DLO (mm)	57 1/4" (1454)	67 1/4" (1708)	69 1/4" (1759)	105 1/4" (2673)

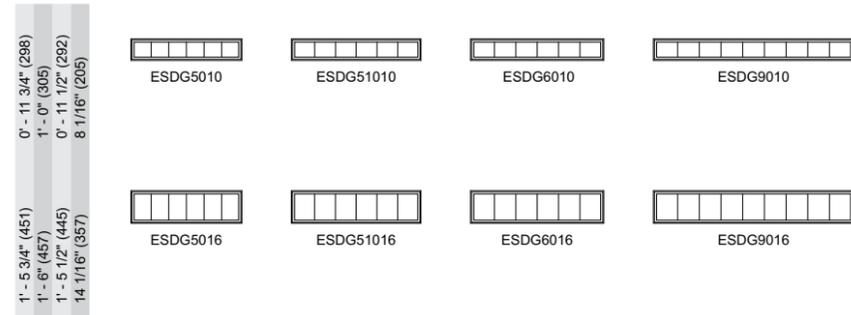

Direct Glaze Over Sliding Patio Door

MO (mm)	6' - 0" (1829)
RO (mm)	6' - 0" (1829)
FS (mm)	5' - 11 1/2" (1816)

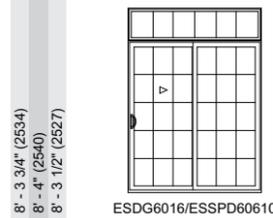

CN Width	MO		RO		FS		DLO	
	in	mm	in	mm	in	mm	in	mm
CN80	8-0	(2438)	8-0	(2438)	7'-11 1/2"	(2426)	7'-9 1/4"	(2318)
CN90	9-0	(2743)	9-0	(2743)	8'-11 1/2"	(2731)	8'-9 1/4"	(2673)

SLIDING PATIO DOOR

Construction Details

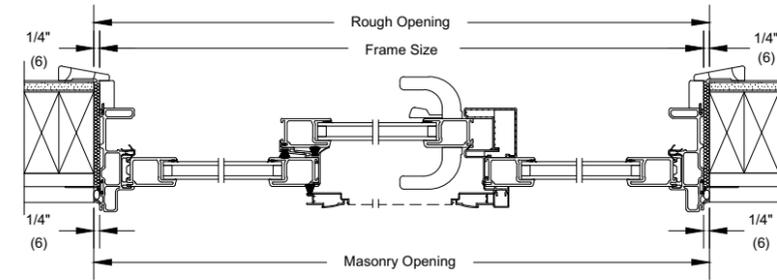

3 Panel OXO Operator Jamb

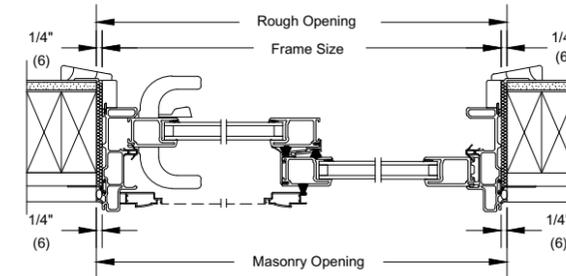

2 Panel XO Operator Jamb

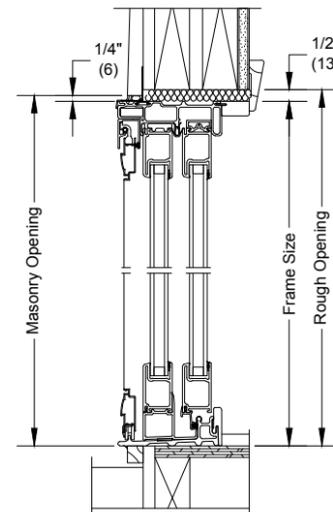

Head Jamb & Sill

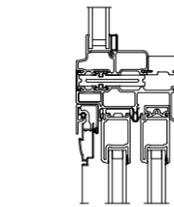

Direct Glaze Over Sliding Patio Door

GBG available in standard Rectangular lite cut, shown above. Other GBG lite cuts shown on page 3. (Not available on In-Sash Transom units)

Details and Elevations not to scale.

Special sized units available within product size matrix. See your Marvin retailer.

See page 56 for specific PG Ratings.

XO operation shown, OX operation optional.

For further details and drawings visit the 'Technical Specifications' section at Marvin.com.

Awning

VENT OPENING				
Unit #	Vent		DLO	
	Sq. Ft.	(cm ²)	Sq. Ft.	(cm ²)
1616	0.74	(689)	0.97	(902)
1620	1.10	(1025)	1.46	(1359)
1626	1.46	(1361)	1.96	(1817)
1630	1.83	(1696)	2.45	(2275)
1636	2.19	(2032)	2.94	(2732)
1640	2.55	(2368)	3.43	(3190)
2016	1.25	(1166)	1.46	(1359)
2020	1.87	(1734)	2.21	(2049)
2026	2.48	(2302)	2.95	(2739)
2030	3.09	(2870)	3.69	(3429)
2036	3.70	(3438)	4.43	(4119)
2040	4.31	(4006)	5.18	(4809)
2616	1.77	(1643)	1.96	(1817)
2620	2.63	(2443)	2.95	(2739)
2626	3.49	(3243)	3.94	(3661)
2630	4.35	(4043)	4.93	(4583)
2636	5.21	(4844)	5.93	(5505)
2640	6.07	(5644)	6.92	(6428)
3016	2.28	(2119)	2.45	(2275)
3020	3.39	(3152)	3.69	(3429)
3026	4.50	(4184)	4.93	(4583)
3030	5.62	(5217)	6.18	(5738)
3036	6.73	(6249)	7.42	(6892)
3040	7.84	(7282)	8.66	(8047)
3616	2.79	(2596)	2.94	(2732)
3620	4.16	(3861)	4.43	(4119)
3626	5.52	(5126)	5.93	(5505)
3630	6.88	(6390)	7.42	(6892)
3636	8.24	(7655)	8.91	(8279)
3640	9.60	(8920)	10.40	(9665)
4016	3.31	(3073)	3.43	(3190)
4020	4.92	(4570)	5.18	(4809)
4026	6.53	(6067)	6.92	(6428)
4030	8.14	(7564)	8.66	(8047)
4036	9.75	(9061)	10.40	(9665)
4040	11.36	(10558)	12.15	(11284)
4616	3.82	(3550)	3.93	(3647)
4620	5.68	(5279)	5.92	(5449)
4626	7.54	(7008)	7.91	(7350)
4630	9.40	(8737)	9.90	(9201)
4636	11.27	(10467)	11.90	(11052)
4640	13.13	(12196)	13.89	(12903)
5016	4.33	(4026)	4.42	(4105)
5020	6.45	(5988)	6.66	(6188)
5026	8.56	(7949)	8.90	(8272)
5030	10.67	(9911)	11.15	(10355)
5036	12.78	(11872)	13.39	(12439)
5040	14.89	(13834)	15.63	(14522)

E These units meet National Egress Codes requiring 5.7 SF clear opening, 20" clear width, and 24" clear height, not to exceed a floor to sill height of 44". Code restrictions may vary depending on local building codes.

* Floor to clear opening is calculated using 6'-10 1/4" from finished floor to rough opening header.

** These units may optionally include a window opening control device tested to ASTM F2090-10, which can be released from the inside without the use of a key, tool, special knowledge, or force greater than that required for normal unit operation.

The information provided in this catalog has been gathered and assembled with every effort made to validate accuracy and consistency of the content. However, Marvin does not make any warranty or guarantee as to this information. Please verify critical product data in Marvin Order Management System (OMS) quotes and at the time of ordering.

EGRESS OPENINGS

Casement

EGRESS OPENING													
Unit #	Egress Width		Egress Height		Egress Clear Opening		Floor To Clear Opening*		Vent		DLO		
	Inches	(mm)	Inches	(mm)	Sq. Ft.	(cm ²)	Sq. Ft.	(cm ²)	Sq. Ft.	(cm ²)	Sq. Ft.	(cm ²)	
1620	8 43/64	(220)	18 5/16	(465)	1.10	(1025)	60 41/64	(1540)	1.10	(1025)	1.46	(1359)	
1626	8 43/64	(220)	24 5/16	(618)	1.46	(1360)	54 41/64	(1388)	1.46	(1360)	1.96	(1817)	
1630	8 43/64	(220)	30 5/16	(770)	1.83	(1696)	48 41/64	(1236)	1.83	(1696)	2.45	(2275)	
1636	8 43/64	(220)	36 5/16	(923)	2.19	(2032)	42 41/64	(1083)	2.19	(2032)	2.94	(2732)	
1640	8 43/64	(220)	42 5/16	(1075)	2.55	(2367)	36 41/64	(931)	2.55	(2367)	3.43	(3190)	
1646	8 43/64	(220)	48 5/16	(1227)	2.91	(2703)	30 41/64	(778)	2.91	(2703)	3.93	(3647)	
1650	8 43/64	(220)	54 5/16	(1380)	3.27	(3038)	24 41/64	(626)	3.27	(3038)	4.42	(4105)	
1656	8 43/64	(220)	60 5/16	(1532)	3.63	(3374)	18 41/64	(474)	3.63	(3374)	4.91	(4563)	
1660	8 43/64	(220)	66 5/16	(1685)	3.99	(3710)	12 41/64	(321)	3.99	(3710)	5.40	(5020)	
1666	8 43/64	(220)	72 5/16	(1837)	4.35	(4045)	6 41/64	(169)	4.35	(4045)	5.90	(5478)	
1670	8 43/64	(220)	78 5/16	(1989)	4.72	(4381)	41/64	(16)	4.72	(4381)	6.39	(5936)	
2020	14 43/64	(373)	18 5/16	(465)	1.87	(1734)	60 41/64	(1540)	1.87	(1734)	2.21	(2049)	
2026	14 43/64	(373)	24 5/16	(618)	2.48	(2302)	54 41/64	(1388)	2.48	(2302)	2.95	(2739)	
2030	14 43/64	(373)	30 5/16	(770)	3.09	(2870)	48 41/64	(1236)	3.09	(2870)	3.69	(3429)	
2036	14 43/64	(373)	36 5/16	(923)	3.70	(3438)	42 41/64	(1083)	3.70	(3438)	4.43	(4119)	
2040	14 43/64	(373)	42 5/16	(1075)	4.31	(4005)	36 41/64	(931)	4.31	(4005)	5.18	(4809)	
2046	14 43/64	(373)	48 5/16	(1227)	4.92	(4573)	30 41/64	(778)	4.92	(4573)	5.92	(5499)	
2050	14 43/64	(373)	54 5/16	(1380)	5.53	(5141)	24 41/64	(626)	5.53	(5141)	6.66	(6188)	
2056	14 43/64	(373)	60 5/16	(1532)	6.15	(5709)	18 41/64	(474)	6.15	(5709)	7.40	(6878)	
2060	14 43/64	(373)	66 5/16	(1685)	6.76	(6277)	12 41/64	(321)	6.76	(6277)	8.15	(7568)	
2066	14 43/64	(373)	72 5/16	(1837)	7.37	(6845)	6 41/64	(169)	7.37	(6845)	8.89	(8258)	
2070	14 43/64	(373)	78 5/16	(1989)	7.98	(7413)	41/64	(16)	7.98	(7413)	9.63	(8948)	
2620	**	20 43/64	(525)	18 5/16	(465)	2.63	(2443)	60 41/64	(1540)	2.63	(2443)	2.95	(2739)
2626	**	20 43/64	(525)	24 5/16	(618)	3.49	(3243)	54 41/64	(1388)	3.49	(3243)	3.94	(3661)
2630	**	20 43/64	(525)	30 5/16	(770)	4.35	(4043)	48 41/64	(1236)	4.35	(4043)	4.93	(4583)
2636	**	20 43/64	(525)	36 5/16	(923)	5.21	(4843)	42 41/64	(1083)	5.21	(4843)	5.93	(5505)
2640	E **	20 43/64	(525)	42 5/16	(1075)	6.07	(5644)	36 41/64	(931)	6.07	(5644)	6.92	(6428)
2646	E **	20 43/64	(525)	48 5/16	(1227)	6.94	(6444)	30 41/64	(778)	6.94	(6444)	7.91	(7350)
2650	E **	20 43/64	(525)	54 5/16	(1380)	7.80	(7244)	24 41/64	(626)	7.80	(7244)	8.90	(8272)
2656	E **	20 43/64	(525)	60 5/16	(1532)	8.66	(8044)	18 41/64	(474)	8.66	(8044)	9.90	(9194)
2660	E **	20 43/64	(525)	66 5/16	(1685)	9.52	(8844)	12 41/64	(321)	9.52	(8844)	10.89	(10116)
2666	E	20 43/64	(525)	72 5/16	(1837)	10.38	(9644)	6 41/64	(169)	10.38	(9644)	11.88	(11038)
2670	E	20 43/64	(525)	78 5/16	(1989)	11.24	(10444)	41/64	(16)	11.24	(10444)	12.87	(11960)
3020	**	26 43/64	(677)	18 5/16	(465)	3.39	(3152)	60 41/64	(1540)	3.39	(3152)	3.69	(3429)
3026	**	26 43/64	(677)	24 5/16	(618)	4.50	(4185)	54 41/64	(1388)	4.50	(4185)	4.93	(4583)
3030	**	26 43/64	(677)	30 5/16	(770)	5.62	(5217)	48 41/64	(1236)	5.62	(5217)	6.18	(5738)
3036	E **	26 43/64	(677)	36 5/16	(923)	6.73	(6249)	42 41/64	(1083)	6.73	(6249)	7.42	(6892)
3040	E **	26 43/64	(677)	42 5/16	(1075)	7.84	(7282)	36 41/64	(931)	7.84	(7282)	8.66	(8047)
3046	E **	26 43/64	(677)	48 5/16	(1227)	8.95	(8314)	30 41/64	(778)	8.95	(8314)	9.90	(9201)
3050	E **	26 43/64	(677)	54 5/16	(1380)	10.06	(9347)	24 41/64	(626)	10.06	(9347)	11.15	(10355)
3056	E **	26 43/64	(677)	60 5/16	(1532)	11.17	(10379)	18 41/64	(474)	11.17	(10379)	12.39	(11510)
3060	E **	26 43/64	(677)	66 5/16	(1685)	12.28	(11411)	12 41/64	(321)	12.28	(11411)	13.63	(12664)
3066	E	25 3/16	(640)	72 5/16	(1837)	12.65	(11748)	6 41/64	(169)	12.65	(11748)	14.87	(13819)
3070	E	25 3/16	(640)	78 5/16	(1989)	13.70	(12723)	41/64	(16)	13.70	(12723)	16.12	(14973)

E These units meet National Egress Codes requiring 5.7 SF clear opening, 20" clear width, and 24" clear height, not to exceed a floor to sill height of 44". Code restrictions may vary depending on local building codes.

* Floor to clear opening is calculated using 6'-10 1/4" from finished floor to rough opening header.

** These units may optionally include a window opening control device tested to ASTM F2090-10, which can be released from the inside without the use of a key, tool, special knowledge, or force greater than that required for normal unit operation.

** WOCD not available on the CN66 and CN70 heights.

The information provided in this catalog has been gathered and assembled with every effort made to validate accuracy and consistency of the content. However, Marvin does not make any warranty or guarantee as to this information. Please verify critical product data in Marvin Order Management System (OMS) quotes and at the time of ordering.

EGRESS OPENINGS

Single Hung Equal Sash

EGRESS OPENING												
Unit #	Egress Width		Egress Height		Egress Clear Opening		Floor To Clear Opening*		Vent		DLO	
	Inches	(mm)	Inches	(mm)	Sq. Ft	Sq. Ft	Sq. Ft.	(cm ²)	Sq. Ft	(cm ²)	Sq. Ft	(cm ²)
1620	14 9/16	(370)	7 13/64	(183)	0.73	(677)	60 41/64	(1540)	0.73	(677)	1.45	(1347)
1626	14 9/16	(370)	10 13/64	(259)	1.03	(959)	54 41/64	(1388)	1.03	(959)	1.97	(1833)
1630	14 9/16	(370)	13 13/64	(336)	1.34	(1241)	48 41/64	(1236)	1.34	(1241)	2.50	(2319)
1636	14 9/16	(370)	16 13/64	(412)	1.64	(1523)	42 41/64	(1083)	1.64	(1523)	3.02	(2805)
1640	14 9/16	(370)	19 13/64	(488)	1.94	(1804)	36 41/64	(931)	1.94	(1804)	3.54	(3292)
1646	14 9/16	(370)	22 13/64	(564)	2.25	(2086)	30 41/64	(778)	2.25	(2086)	4.07	(3778)
1650	14 9/16	(370)	25 13/64	(640)	2.55	(2368)	24 41/64	(626)	2.55	(2368)	4.59	(4264)
1656	14 9/16	(370)	28 13/64	(717)	2.85	(2650)	18 41/64	(474)	2.85	(2650)	5.11	(4750)
1660	14 9/16	(370)	31 13/64	(793)	3.16	(2932)	12 41/64	(321)	3.16	(2932)	5.64	(5236)
1666	14 9/16	(370)	34 13/64	(869)	3.46	(3214)	6 41/64	(169)	3.46	(3214)	6.16	(5722)
2020	20 9/16	(522)	7 13/64	(183)	1.03	(956)	60 41/64	(1540)	1.03	(956)	2.14	(1990)
2026	20 9/16	(522)	10 13/64	(259)	1.46	(1354)	54 41/64	(1388)	1.46	(1354)	2.92	(2709)
2030	20 9/16	(522)	13 13/64	(336)	1.89	(1752)	48 41/64	(1236)	1.89	(1752)	3.69	(3427)
2036	20 9/16	(522)	16 13/64	(412)	2.31	(2150)	42 41/64	(1083)	2.31	(2150)	4.46	(4145)
2040	20 9/16	(522)	19 13/64	(488)	2.74	(2548)	36 41/64	(931)	2.74	(2548)	5.24	(4864)
2046	20 9/16	(522)	22 13/64	(564)	3.17	(2946)	30 41/64	(778)	3.17	(2946)	6.01	(5582)
2050	20 9/16	(522)	25 13/64	(640)	3.60	(3344)	24 41/64	(626)	3.60	(3344)	6.78	(6301)
2056	20 9/16	(522)	28 13/64	(717)	4.03	(3742)	18 41/64	(474)	4.03	(3742)	7.56	(7019)
2060	20 9/16	(522)	31 13/64	(793)	4.46	(4140)	12 41/64	(321)	4.46	(4140)	8.33	(7738)
2066	20 9/16	(522)	34 13/64	(869)	4.88	(4538)	6 41/64	(169)	4.88	(4538)	9.10	(8456)
2620	26 9/16	(675)	7 13/64	(183)	1.33	(1235)	60 41/64	(1540)	1.33	(1235)	2.83	(2633)
2626	26 9/16	(675)	10 13/64	(259)	1.88	(1750)	54 41/64	(1388)	1.88	(1750)	3.86	(3584)
2630	26 9/16	(675)	13 13/64	(336)	2.44	(2264)	48 41/64	(1236)	2.44	(2264)	4.88	(4535)
2636	26 9/16	(675)	16 13/64	(412)	2.99	(2778)	42 41/64	(1083)	2.99	(2778)	5.90	(5486)
2640	26 9/16	(675)	19 13/64	(488)	3.54	(3292)	36 41/64	(931)	3.54	(3292)	6.93	(6436)
2646	26 9/16	(675)	22 13/64	(564)	4.10	(3806)	30 41/64	(778)	4.10	(3806)	7.95	(7387)
2650	26 9/16	(675)	25 13/64	(640)	4.65	(4320)	24 41/64	(626)	4.65	(4320)	8.97	(8338)
2656	26 9/16	(675)	28 13/64	(717)	5.20	(4834)	18 41/64	(474)	5.20	(4834)	10.00	(9288)
2660	E 26 9/16	(675)	31 13/64	(793)	5.76	(5348)	12 41/64	(321)	5.76	(5348)	11.02	(10239)
2666	E 26 9/16	(675)	34 13/64	(869)	6.31	(5862)	6 41/64	(169)	6.31	(5862)	12.04	(11190)
2820	28 9/16	(725)	7 13/64	(183)	1.43	(1328)	60 41/64	(1540)	1.43	(1328)	3.07	(2848)
2826	28 9/16	(725)	10 13/64	(259)	2.02	(1881)	54 41/64	(1388)	2.02	(1881)	4.17	(3876)
2830	28 9/16	(725)	13 13/64	(336)	2.62	(2434)	48 41/64	(1236)	2.62	(2434)	5.28	(4904)
2836	28 9/16	(725)	16 13/64	(412)	3.21	(2987)	42 41/64	(1083)	3.21	(2987)	6.39	(5932)
2840	28 9/16	(725)	19 13/64	(488)	3.81	(3540)	36 41/64	(931)	3.81	(3540)	7.49	(6960)
2846	28 9/16	(725)	22 13/64	(564)	4.40	(4092)	30 41/64	(778)	4.40	(4092)	8.60	(7989)
2850	28 9/16	(725)	25 13/64	(640)	5.00	(4645)	24 41/64	(626)	5.00	(4645)	9.71	(9017)
2856	28 9/16	(725)	28 13/64	(717)	5.59	(5198)	18 41/64	(474)	5.59	(5198)	10.81	(10045)
2860	E 28 9/16	(725)	31 13/64	(793)	6.19	(5751)	12 41/64	(321)	6.19	(5751)	11.92	(11073)
2866	E 28 9/16	(725)	34 13/64	(869)	6.78	(6303)	6 41/64	(169)	6.78	(6303)	13.03	(12101)
3020	32 9/16	(827)	7 13/64	(183)	1.63	(1515)	60 41/64	(1540)	1.63	(1515)	3.53	(3277)
3026	32 9/16	(827)	10 13/64	(259)	2.31	(2145)	54 41/64	(1388)	2.31	(2145)	4.80	(4460)
3030	32 9/16	(827)	13 13/64	(336)	2.99	(2775)	48 41/64	(1236)	2.99	(2775)	6.07	(5643)
3036	32 9/16	(827)	16 13/64	(412)	3.67	(3405)	42 41/64	(1083)	3.67	(3405)	7.35	(6826)
3040	32 9/16	(827)	19 13/64	(488)	4.34	(4035)	36 41/64	(931)	4.34	(4035)	8.62	(8009)
3046	32 9/16	(827)	22 13/64	(564)	5.02	(4666)	30 41/64	(778)	5.02	(4666)	9.89	(9192)
3050	E 32 9/16	(827)	25 13/64	(640)	5.70	(5296)	24 41/64	(626)	5.70	(5296)	11.17	(10375)
3056	E 32 9/16	(827)	28 13/64	(717)	6.38	(5926)	18 41/64	(474)	6.38	(5926)	12.44	(11558)
3060	E 32 9/16	(827)	31 13/64	(793)	7.06	(6556)	12 41/64	(321)	7.06	(6556)	13.71	(12741)
3066	E 32 9/16	(827)	34 13/64	(869)	7.74	(7186)	6 41/64	(169)	7.74	(7186)	14.99	(13924)
3620	38 9/16	(979)	7 13/64	(183)	1.93	(1794)	60 41/64	(1540)	1.93	(1794)	4.22	(3920)
3626	38 9/16	(979)	10 13/64	(259)	2.73	(2540)	54 41/64	(1388)	2.73	(2540)	5.74	(5335)
3630	38 9/16	(979)	13 13/64	(336)	3.54	(3286)	48 41/64	(1236)	3.54	(3286)	7.27	(6751)
3636	38 9/16	(979)	16 13/64	(412)	4.34	(4033)	42 41/64	(1083)	4.34	(4033)	8.79	(8166)
3640	38 9/16	(979)	19 13/64	(488)	5.14	(4779)	36 41/64	(931)	5.14	(4779)	10.31	(9581)
3646	38 9/16	(979)	22 13/64	(564)	5.95	(5525)	30 41/64	(778)	5.95	(5525)	11.84	(10996)
3650	E 38 9/16	(979)	25 13/64	(640)	6.75	(6272)	24 41/64	(626)	6.75	(6272)	13.36	(12412)
3656	E 38 9/16	(979)	28 13/64	(717)	7.55	(7018)	18 41/64	(474)	7.55	(7018)	14.88	(13827)
3660	E 38 9/16	(979)	31 13/64	(793)	8.36	(7764)	12 41/64	(321)	8.36	(7764)	16.41	(15242)
3666	E 38 9/16	(979)	34 13/64	(869)	9.16	(8511)	6 41/64	(169)	9.16	(8511)	17.93	(16657)
4020	44 9/16	(1132)	7 13/64	(183)	2.23	(2073)	60 41/64	(1540)	2.23	(2073)	4.91	(4564)
4026	44 9/16	(1132)	10 13/64	(259)	3.16	(2935)	54 41/64	(1388)	3.16	(2935)	6.69	(6211)
4030	44 9/16	(1132)	13 13/64	(336)	4.09	(3798)	48 41/64	(1236)	4.09	(3798)	8.46	(7858)
4036	44 9/16	(1132)	16 13/64	(412)	5.02	(4660)	42 41/64	(1083)	5.02	(4660)	10.23	(9506)
4040	44 9/16	(1132)	19 13/64	(488)	5.94	(5523)	36 41/64	(931)	5.94	(5523)	12.01	(11153)
4046	44 9/16	(1132)	22 13/64	(564)	6.87	(6385)	30 41/64	(778)	6.87	(6385)	13.78	(12801)
4050	E 44 9/16	(1132)	25 13/64	(640)	7.80	(7247)	24 41/64	(626)	7.80	(7247)	15.55	(14448)
4056	E 44 9/16	(1132)	28 13/64	(717)	8.73	(8110)	18 41/64	(474)	8.73	(8110)	17.33	(16096)
4060	E 44 9/16	(1132)	31 13/64	(793)	9.66	(8972)	12 41/64	(321)	9.66	(8972)	19.10	(17743)
4066	E 44 9/16	(1132)	34 13/64	(869)	10.59	(9835)	6 41/64	(169)	10.59	(9835)	20.87	(19391)

E These units meet National Egress Codes requiring 5.7 SF clear opening, 20" clear width, and 24" clear height, not to exceed a floor to sill height of 44". Code restrictions may vary depending on local building codes.

* Floor to clear opening is calculated using 6'-10 1/4" from finished floor to rough opening header.

Units may optionally include a window opening control device tested to ASTM F2090-10, which can be released from the inside without the use of a key, tool, special knowledge, or force greater than that required for normal unit operation.

For further details and drawings visit the 'Technical Specifications' section at Marvin.com.

EGRESS OPENINGS

Single Hung Cottage

EGRESS OPENING														
Unit #	Egress Width		Egress Height		Egress Clear Opening		Floor To Clear Opening*		Vent		DLO		Check Rail Height	
	Inches	(mm)	Inches	(mm)	Sq. Ft.	(cm ²)	Inches	(mm)	Sq. Ft.	(cm ²)	Sq. Ft.	(cm ²)	Inches	(mm)
1626	14 9/16	(370)	7 23/32	(196)	0.78	(725)	54 41/64	(1388)	0.78	(725)	2.41	(2235)	17 11/16	(449)
1630	14 9/16	(370)	10 1/8	(257)	1.02	(951)	48 41/64	(1236)	1.02	(951)	3.03	(2818)	21 9/32	(541)
1636	14 9/16	(370)	12 33/64	(318)	1.27	(1176)	42 41/64	(1083)	1.27	(1176)	3.66	(3402)	24 7/8	(632)
1640	14 9/16	(370)	14 59/64	(379)	1.51	(1402)	36 41/64	(931)	1.51	(1402)	4.29	(3985)	28 31/64	(723)
1646	14 9/16	(370)	17 5/16	(440)	1.75	(1627)	30 41/64	(778)	1.75	(1627)	4.92	(4569)	32 5/64	(815)
1650	14 9/16	(370)	19 23/32	(501)	1.99	(1852)	24 41/64	(626)	1.99	(1852)	5.55	(5152)	35 11/16	(906)
1656	14 9/16	(370)	22 13/64	(564)	2.25	(2086)	18 41/64	(474)	2.25	(2086)	6.16	(5722)	39 3/16	(995)
1660	14 9/16	(370)	24 33/64	(623)	2.48	(2304)	12 41/64	(321)	2.48	(2304)	6.80	(6320)	42 7/8	(1089)
1666	14 9/16	(370)	26 59/64	(684)	2.72	(2529)	6 41/64	(169)	2.72	(2529)	7.43	(6903)	46 31/64	(1181)
2026	20 9/16	(522)	7 23/32	(196)	1.10	(1024)	54 41/64	(1388)	1.10	(1024)	3.55	(3302)	17 11/16	(449)
2030	20 9/16	(522)	10 1/8	(257)	1.44	(1342)	48 41/64	(1236)	1.44	(1342)	4.48	(4165)	21 9/32	(541)
2036	20 9/16	(522)	12 33/64	(318)	1.79	(1661)	42 41/64	(1083)	1.79	(1661)	5.41	(5027)	24 7/8	(632)
2040	20 9/16	(522)	14 59/64	(379)	2.13	(1979)	36 41/64	(931)	2.13	(1979)	6.34	(5889)	28 31/64	(723)
2046	20 9/16	(522)	17 5/16	(440)	2.47	(2297)	30 41/64	(778)	2					

EGRESS OPENINGS

Single Hung Reverse Cottage

EGRESS OPENING														
Unit #	Egress Width		Egress Height		Egress Clear Opening		Floor To Clear Opening*		Vent		DLO		Check Rail Height	
	Inches	(mm)	Inches	(mm)	Sq. Ft.	(cm ²)	Inches	(mm)	Sq. Ft.	(cm ²)	Sq. Ft.	(cm ²)	Inches	(mm)
1626	14 9/16	(370)	7 23/32	(196)	0.78	(725)	54 41/64	(1388)	0.78	(725)	1.54	(1431)	12 45/64	(323)
1630	14 9/16	(370)	10 1/8	(257)	1.02	(951)	48 41/64	(1236)	1.02	(951)	1.96	(1820)	15 7/64	(384)
1636	14 9/16	(370)	12 33/64	(318)	1.27	(1176)	42 41/64	(1083)	1.27	(1176)	2.38	(2209)	17 33/64	(445)
1640	14 9/16	(370)	14 59/64	(379)	1.51	(1402)	36 41/64	(931)	1.51	(1402)	2.80	(2598)	19 29/32	(506)
1646	14 9/16	(370)	17 5/16	(440)	1.75	(1627)	30 41/64	(778)	1.75	(1627)	3.22	(2987)	22 5/16	(567)
1650	14 9/16	(370)	19 23/32	(501)	1.99	(1852)	24 41/64	(626)	1.99	(1852)	3.63	(3376)	24 45/64	(628)
1656	14 9/16	(370)	22 13/64	(564)	2.25	(2086)	18 41/64	(474)	2.25	(2086)	4.07	(3778)	27 3/16	(691)
1660	14 9/16	(370)	24 33/64	(623)	2.48	(2304)	12 41/64	(321)	2.48	(2304)	4.47	(4153)	29 33/64	(750)
1666	14 9/16	(370)	26 59/64	(684)	2.72	(2529)	6 41/64	(169)	2.72	(2529)	4.89	(4542)	31 29/32	(810)
2026	20 9/16	(522)	7 23/32	(196)	1.10	(1024)	54 41/64	(1388)	1.10	(1024)	2.28	(2115)	12 45/64	(323)
2030	20 9/16	(522)	10 1/8	(257)	1.44	(1342)	48 41/64	(1236)	1.44	(1342)	2.89	(2689)	15 7/64	(384)
2036	20 9/16	(522)	12 33/64	(318)	1.79	(1661)	42 41/64	(1083)	1.79	(1661)	3.51	(3264)	17 33/64	(445)
2040	20 9/16	(522)	14 59/64	(379)	2.13	(1979)	36 41/64	(931)	2.13	(1979)	4.13	(3839)	19 29/32	(506)
2046	20 9/16	(522)	17 5/16	(440)	2.47	(2297)	30 41/64	(778)	2.47	(2297)	4.75	(4414)	22 5/16	(567)
2050	20 9/16	(522)	19 23/32	(501)	2.82	(2616)	24 41/64	(626)	2.82	(2616)	5.37	(4988)	24 45/64	(628)
2056	20 9/16	(522)	22 13/64	(564)	3.17	(2946)	18 41/64	(474)	3.17	(2946)	6.01	(5582)	27 3/16	(691)
2060	20 9/16	(522)	24 33/64	(623)	3.50	(3253)	12 41/64	(321)	3.50	(3253)	6.61	(6137)	29 33/64	(750)
2066	20 9/16	(522)	26 59/64	(684)	3.84	(3571)	6 41/64	(169)	3.84	(3571)	7.22	(6712)	31 29/32	(810)
2626	26 9/16	(675)	7 23/32	(196)	1.42	(1323)	54 41/64	(1388)	1.42	(1323)	3.01	(2798)	12 45/64	(323)
2630	26 9/16	(675)	10 1/8	(257)	1.87	(1734)	48 41/64	(1236)	1.87	(1734)	3.83	(3559)	15 7/64	(384)
2636	26 9/16	(675)	12 33/64	(318)	2.31	(2145)	42 41/64	(1083)	2.31	(2145)	4.65	(4319)	17 33/64	(445)
2640	26 9/16	(675)	14 59/64	(379)	2.75	(2557)	36 41/64	(931)	2.75	(2557)	5.47	(5080)	19 29/32	(506)
2646	26 9/16	(675)	17 5/16	(440)	3.19	(2968)	30 41/64	(778)	3.19	(2968)	6.29	(5841)	22 5/16	(567)
2650	26 9/16	(675)	19 23/32	(501)	3.64	(3379)	24 41/64	(626)	3.64	(3379)	7.11	(6601)	24 45/64	(628)
2656	26 9/16	(675)	22 13/64	(564)	4.10	(3806)	18 41/64	(474)	4.10	(3806)	7.95	(7387)	27 3/16	(691)
2660	26 9/16	(675)	24 33/64	(623)	4.52	(4202)	12 41/64	(321)	4.52	(4202)	8.74	(8121)	29 33/64	(750)
2666	26 9/16	(675)	26 59/64	(684)	4.97	(4613)	6 41/64	(169)	4.97	(4613)	9.56	(8882)	31 29/32	(810)
2826	28 9/16	(725)	7 23/32	(196)	1.53	(1422)	54 41/64	(1388)	1.53	(1422)	3.26	(3026)	12 45/64	(323)
2830	28 9/16	(725)	10 1/8	(257)	2.01	(1865)	48 41/64	(1236)	2.01	(1865)	4.14	(3849)	15 7/64	(384)
2836	28 9/16	(725)	12 33/64	(318)	2.48	(2307)	42 41/64	(1083)	2.48	(2307)	5.03	(4671)	17 33/64	(445)
2840	28 9/16	(725)	14 59/64	(379)	2.94	(2749)	36 41/64	(931)	2.96	(2749)	5.91	(5494)	19 29/32	(506)
2846	28 9/16	(725)	17 5/16	(440)	3.44	(3191)	30 41/64	(778)	3.44	(3191)	6.80	(6316)	22 5/16	(567)
2850	28 9/16	(725)	19 23/32	(501)	3.91	(3634)	24 41/64	(626)	3.91	(3634)	7.68	(7139)	24 45/64	(628)
2856	28 9/16	(725)	22 13/64	(564)	4.40	(4092)	18 41/64	(474)	4.40	(4092)	8.60	(7989)	27 3/16	(691)
2860	28 9/16	(725)	24 33/64	(623)	4.86	(4519)	12 41/64	(321)	4.86	(4519)	9.45	(8782)	29 33/64	(750)
2866	28 9/16	(725)	26 59/64	(684)	5.34	(4961)	6 41/64	(169)	5.34	(4961)	10.34	(9605)	31 29/32	(810)
3026	32 9/16	(827)	7 23/32	(196)	1.75	(1622)	54 41/64	(1388)	1.75	(1622)	3.75	(3482)	12 45/64	(323)
3030	32 9/16	(827)	10 1/8	(257)	2.29	(2126)	48 41/64	(1236)	2.29	(2126)	4.77	(4428)	15 7/64	(384)
3036	32 9/16	(827)	12 33/64	(318)	2.83	(2630)	42 41/64	(1083)	2.83	(2630)	5.79	(5375)	17 33/64	(445)
3040	32 9/16	(827)	14 59/64	(379)	3.37	(3134)	36 41/64	(931)	3.37	(3134)	6.80	(6321)	19 29/32	(506)
3046	32 9/16	(827)	17 5/16	(440)	3.92	(3638)	30 41/64	(778)	3.92	(3638)	7.82	(7267)	22 5/16	(567)
3050	32 9/16	(827)	19 23/32	(501)	4.46	(4142)	24 41/64	(626)	4.46	(4142)	8.84	(8214)	24 45/64	(628)
3056	32 9/16	(827)	22 13/64	(564)	5.02	(4666)	18 41/64	(474)	5.02	(4666)	9.89	(9192)	27 3/16	(691)
3060	32 9/16	(827)	24 33/64	(623)	5.54	(5151)	12 41/64	(321)	5.54	(5151)	10.88	(10105)	29 33/64	(750)
3066	E 32 9/16	(827)	26 59/64	(684)	6.09	(5656)	6 41/64	(169)	6.09	(5656)	11.90	(11051)	31 29/32	(810)
3626	38 9/16	(979)	7 23/32	(196)	2.07	(1921)	54 41/64	(1388)	2.07	(1921)	4.48	(4165)	12 45/64	(323)
3630	38 9/16	(979)	10 1/8	(257)	2.71	(2518)	48 41/64	(1236)	2.71	(2518)	5.70	(5298)	15 7/64	(384)
3636	38 9/16	(979)	12 33/64	(318)	3.35	(3115)	42 41/64	(1083)	3.35	(3115)	6.92	(6430)	17 33/64	(445)
3640	38 9/16	(979)	14 59/64	(379)	4.00	(3712)	36 41/64	(931)	4.00	(3712)	8.14	(7562)	19 29/32	(506)
3646	38 9/16	(979)	17 5/16	(440)	4.64	(4309)	30 41/64	(778)	4.64	(4309)	9.36	(8694)	22 5/16	(567)
3650	38 9/16	(979)	19 23/32	(501)	5.28	(4906)	24 41/64	(626)	5.28	(4906)	10.58	(9826)	24 45/64	(628)
3656	38 9/16	(979)	22 13/64	(564)	5.95	(5525)	18 41/64	(474)	5.95	(5525)	11.84	(10996)	27 3/16	(691)
3660	E 38 9/16	(979)	24 33/64	(623)	6.57	(6101)	12 41/64	(321)	6.57	(6101)	13.01	(12089)	29 33/64	(750)
3666	E 38 9/16	(979)	26 59/64	(684)	7.21	(6698)	6 41/64	(169)	7.21	(6698)	14.23	(13221)	31 29/32	(810)
4026	44 9/16	(1132)	7 23/32	(196)	2.39	(2219)	54 41/64	(1388)	2.39	(2219)	5.22	(4849)	12 45/64	(323)
4030	44 9/16	(1132)	10 1/8	(257)	3.13	(2909)	48 41/64	(1236)	3.13	(2909)	6.64	(6167)	15 7/64	(384)
4036	44 9/16	(1132)	12 33/64	(318)	3.87	(3599)	42 41/64	(1083)	3.87	(3599)	8.06	(7485)	17 33/64	(445)
4040	44 9/16	(1132)	14 59/64	(379)	4.62	(4289)	36 41/64	(931)	4.62	(4289)	9.48	(8803)	19 29/32	(506)
4046	44 9/16	(1132)	17 5/16	(440)	5.36	(4979)	30 41/64	(778)	5.36	(4979)	10.89	(10121)	22 5/16	(567)
4050	44 9/16	(1132)	19 23/32	(501)	6.10	(5669)	24 41/64	(626)	6.10	(5669)	12.31	(11439)	24 45/64	(628)
4056	44 9/16	(1132)	22 13/64	(564)	6.87	(6385)	18 41/64	(474)	6.87	(6385)	13.78	(12801)	27 3/16	(691)
4060	E 44 9/16	(1132)	24 33/64	(623)	7.59	(7050)	12 41/64	(321)	7.59	(7050)	15.15	(14073)	29 33/64	(750)
4066	E 44 9/16	(1132)	26 59/64	(684)	8.33	(7740)	6 41/64	(169)	8.33	(7740)	16.57	(15391)	31 29/32	(810)

E These units meet National Egress Codes requiring 5.7 SF clear opening, 20" clear width, and 24" clear height, not to exceed a floor to sill height of 44". Code restrictions may vary depending on local building codes.

* Floor to clear opening is calculated using 6'-10 1/4" from finished floor to rough opening header.

Units may optionally include a window opening control device tested to ASTM F2090-10, which can be released from the inside without the use of a key, tool, special knowledge, or force greater than that required for normal unit operation.

For further details and drawings visit the 'Technical Specifications' section at Marvin.com.

EGRESS OPENINGS

Double Hung Equal Sash

EGRESS OPENING													
Unit #	Egress Width		Egress Height		Egress Clear Opening		Floor To Clear Opening*		Vent		DLO		Check Rail Height
	Inches	(mm)	Inches	(mm)	Sq. Ft.	(cm ²)	Sq. Ft.	(cm ²)	Sq. Ft.	(cm ²)	Sq. Ft.	(cm ²)	
1620	14 9/16	(370)	7 13/64	(183)	0.73	(677)	60 41/64	(1540)	0.73	(677)	1.45	(1347)	
1626	14 9/16	(370)	10 13/64	(259)	1.03	(959)	54 41/64	(1388)	1.03	(959)	1.97	(1833)	
1630	14 9/16	(370)	13 13/64	(336)	1.34	(1241)	48 41/64	(1236)	1.34	(1241)	2.50	(2319)	
1636	14 9/16	(370)	16 13/64	(412)	1.64	(1523)	42 41/64	(1083)	1.64	(1523)	3.02	(2805)	
1640	14 9/16	(370)	19 13/64	(488)	1.94	(1804)	36 41/64	(931)	1.94	(1804)	3.54	(3292)	
1646	14 9/16	(370)	22 13/64	(564)	2.25	(2086)	30 41/64	(778)	2.25	(2086)	4.07	(3778)	
1650	14 9/16	(370)	25 13/64	(640)	2.55	(2368)	24 41/64	(626)	2.55	(2368)	4.59	(4264)	
1656	14 9/16	(370)	28 13/64	(717)	2.85	(2650)	18 41/64	(474)	2.85	(2650)	5.11	(4750)	
1660	14 9/16	(370)	31 13/64	(793)	3.16	(2932)	12 41/64	(321)	3.16	(2932)	5.64	(5236)	
1666	14 9/16	(370)	34 13/64	(869)	3.46	(3214)	6 41/64	(169)	3.46	(3214)	6.16	(5722)	
2020	20 9/16	(522)	7 13/64	(183)	1.03	(956)	60 41/64	(1540)	1.03	(956)	2.14	(1990)	
2026	20 9/16	(522)	10 13/64	(259)	1.46	(1354)	54 41/64	(1388)	1.46	(1354)	2.92	(2709)	
2030	20 9/16	(522)	13 13/64	(336)	1.89	(1752)	48 41/64	(1236)	1.89	(1752)	3.69	(3427)	

EGRESS OPENINGS

Double Hung Cottage

EGRESS OPENING														
Unit #	Egress Width		Egress Height		Egress Clear Opening		Floor To Clear Opening*		Vent		DLO		Check Rail Height	
	Inches	(mm)	Inches	(mm)	Sq. Ft.	(cm ²)	Inches	(mm)	Sq. Ft.	(cm ²)	Sq. Ft.	(cm ²)	Inches	(mm)
1626	14 9/16	(370)	7 23/32	(196)	0.78	(725)	54 41/64	(1388)	0.78	(725)	2.41	(2235)	17 11/16	(449)
1630	14 9/16	(370)	10 1/8	(257)	1.02	(951)	48 41/64	(1236)	1.02	(951)	3.03	(2818)	21 9/32	(541)
1636	14 9/16	(370)	12 33/64	(318)	1.27	(1176)	42 41/64	(1083)	1.27	(1176)	3.66	(3402)	24 7/8	(632)
1640	14 9/16	(370)	14 59/64	(379)	1.51	(1402)	36 41/64	(931)	1.51	(1402)	4.29	(3985)	28 31/64	(723)
1646	14 9/16	(370)	17 5/16	(440)	1.75	(1627)	30 41/64	(778)	1.75	(1627)	4.92	(4569)	32 5/64	(815)
1650	14 9/16	(370)	19 23/32	(501)	1.99	(1852)	24 41/64	(626)	1.99	(1852)	5.55	(5152)	35 11/16	(906)
1656	14 9/16	(370)	22 13/64	(564)	2.25	(2086)	18 41/64	(474)	2.25	(2086)	6.16	(5722)	39 3/16	(995)
2026	20 9/16	(522)	7 23/32	(196)	1.10	(1024)	54 41/64	(1388)	1.10	(1024)	3.55	(3302)	17 11/16	(449)
2030	20 9/16	(522)	10 1/8	(257)	1.44	(1342)	48 41/64	(1236)	1.44	(1342)	4.48	(4165)	21 9/32	(541)
2036	20 9/16	(522)	12 33/64	(318)	1.79	(1661)	42 41/64	(1083)	1.79	(1661)	5.41	(5027)	24 7/8	(632)
2040	20 9/16	(522)	14 59/64	(379)	2.13	(1979)	36 41/64	(931)	2.13	(1979)	6.34	(5889)	28 31/64	(723)
2046	20 9/16	(522)	17 5/16	(440)	2.47	(2297)	30 41/64	(778)	2.47	(2297)	7.27	(6751)	32 5/64	(815)
2050	20 9/16	(522)	19 23/32	(501)	2.82	(2616)	24 41/64	(626)	2.82	(2616)	8.19	(7613)	35 11/16	(906)
2056	20 9/16	(522)	22 13/64	(564)	3.17	(2946)	18 41/64	(474)	3.17	(2946)	9.10	(8456)	39 3/16	(995)
2626	26 9/16	(675)	7 23/32	(196)	1.42	(1323)	54 41/64	(1388)	1.42	(1323)	4.70	(4370)	17 11/16	(449)
2630	26 9/16	(675)	10 1/8	(257)	1.87	(1734)	48 41/64	(1236)	1.87	(1734)	5.93	(5511)	21 9/32	(541)
2636	26 9/16	(675)	12 33/64	(318)	2.31	(2145)	42 41/64	(1083)	2.31	(2145)	7.16	(6652)	24 7/8	(632)
2640	26 9/16	(675)	14 59/64	(379)	2.75	(2557)	36 41/64	(931)	2.75	(2557)	8.39	(7793)	28 31/64	(723)
2646	26 9/16	(675)	17 5/16	(440)	3.19	(2968)	30 41/64	(778)	3.19	(2968)	9.62	(8933)	32 5/64	(815)
2650	26 9/16	(675)	19 23/32	(501)	3.64	(3379)	24 41/64	(626)	3.64	(3379)	10.84	(10074)	35 11/16	(906)
2656	26 9/16	(675)	22 13/64	(564)	4.10	(3806)	18 41/64	(474)	4.10	(3806)	12.04	(11190)	39 3/16	(995)
2826	28 9/16	(725)	7 23/32	(196)	1.53	(1422)	54 41/64	(1388)	1.53	(1422)	5.09	(4726)	17 11/16	(449)
2830	28 9/16	(725)	10 1/8	(257)	2.01	(1865)	48 41/64	(1236)	2.01	(1865)	6.41	(5960)	21 9/32	(541)
2836	28 9/16	(725)	12 33/64	(318)	2.48	(2307)	42 41/64	(1083)	2.48	(2307)	7.74	(7193)	24 7/8	(632)
2840	28 9/16	(725)	14 59/64	(379)	2.96	(2749)	36 41/64	(931)	2.96	(2749)	9.07	(8427)	28 31/64	(723)
2846	28 9/16	(725)	17 5/16	(440)	3.44	(3191)	30 41/64	(778)	3.44	(3191)	10.40	(9661)	32 5/64	(815)
2850	28 9/16	(725)	19 23/32	(501)	3.91	(3634)	24 41/64	(626)	3.91	(3634)	11.73	(10895)	35 11/16	(906)
2856	28 9/16	(725)	22 13/64	(564)	4.40	(4092)	18 41/64	(474)	4.40	(4092)	13.03	(12101)	39 3/16	(995)
3026	32 9/16	(827)	7 23/32	(196)	1.75	(1622)	54 41/64	(1388)	1.75	(1622)	5.85	(5438)	17 11/16	(449)
3030	32 9/16	(827)	10 1/8	(257)	2.29	(2126)	48 41/64	(1236)	2.29	(2126)	7.38	(6857)	21 9/32	(541)
3036	32 9/16	(827)	12 33/64	(318)	2.83	(2630)	42 41/64	(1083)	2.83	(2630)	8.91	(8277)	24 7/8	(632)
3040	32 9/16	(827)	14 59/64	(379)	3.37	(3134)	36 41/64	(931)	3.37	(3134)	10.44	(9696)	28 31/64	(723)
3046	32 9/16	(827)	17 5/16	(440)	3.92	(3638)	30 41/64	(778)	3.92	(3638)	11.97	(11116)	32 5/64	(815)
3050	32 9/16	(827)	19 23/32	(501)	4.46	(4142)	24 41/64	(626)	4.46	(4142)	13.49	(12535)	35 11/16	(906)
3056	32 9/16	(827)	22 13/64	(564)	5.02	(4666)	18 41/64	(474)	5.02	(4666)	14.99	(13924)	39 3/16	(995)
3626	38 9/16	(979)	7 23/32	(196)	2.07	(1921)	54 41/64	(1388)	2.07	(1921)	7.00	(6505)	17 11/16	(449)
3630	38 9/16	(979)	10 1/8	(257)	2.71	(2518)	48 41/64	(1236)	2.71	(2518)	8.83	(8204)	21 9/32	(541)
3636	38 9/16	(979)	12 33/64	(318)	3.35	(3115)	42 41/64	(1083)	3.35	(3115)	10.66	(9902)	24 7/8	(632)
3640	38 9/16	(979)	14 59/64	(379)	4.00	(3712)	36 41/64	(931)	4.00	(3712)	12.49	(11600)	28 31/64	(723)
3646	38 9/16	(979)	17 5/16	(440)	4.64	(4309)	30 41/64	(778)	4.64	(4309)	14.31	(13298)	32 5/64	(815)
3650	38 9/16	(979)	19 23/32	(501)	5.28	(4906)	24 41/64	(626)	5.28	(4906)	16.14	(14997)	35 11/16	(906)
3656	38 9/16	(979)	22 13/64	(564)	5.95	(5525)	18 41/64	(474)	5.95	(5525)	17.93	(16657)	39 3/16	(995)
4026	44 9/16	(1132)	7 23/32	(196)	2.39	(2219)	54 41/64	(1388)	2.39	(2219)	8.15	(7573)	17 11/16	(449)
4030	44 9/16	(1132)	10 1/8	(257)	3.13	(2909)	48 41/64	(1236)	3.13	(2909)	10.28	(9550)	21 9/32	(541)
4036	44 9/16	(1132)	12 33/64	(318)	3.87	(3599)	42 41/64	(1083)	3.87	(3599)	12.41	(11527)	24 7/8	(632)
4040	44 9/16	(1132)	14 59/64	(379)	4.62	(4289)	36 41/64	(931)	4.62	(4289)	14.54	(13504)	28 31/64	(723)
4046	44 9/16	(1132)	17 5/16	(440)	5.36	(4979)	30 41/64	(778)	5.36	(4979)	16.66	(15481)	32 5/64	(815)
4050	44 9/16	(1132)	19 23/32	(501)	6.10	(5669)	24 41/64	(626)	6.10	(5669)	18.79	(17458)	35 11/16	(906)
4056	44 9/16	(1132)	22 13/64	(564)	6.87	(6385)	18 41/64	(474)	6.87	(6385)	20.87	(19391)	39 3/16	(995)

E These units meet National Egress Codes requiring 5.7 SF clear opening, 20" clear width, and 24" clear height, not to exceed a floor to sill height of 44". Code restrictions may vary depending on local building codes.

* Floor to clear opening is calculated using 6'-10 1/4" from finished floor to rough opening header.

Units may optionally include a window opening control device tested to ASTM F2090-10, which can be released from the inside without the use of a key, tool, special knowledge, or force greater than that required for normal unit operation.

For further details and drawings visit the 'Technical Specifications' section at Marvin.com.

The information provided in this catalog has been gathered and assembled with every effort made to validate accuracy and consistency of the content. However, Marvin does not make any warranty or guarantee as to this information. Please verify critical product data in Marvin Order Management System (OMS) quotes and at the time of ordering.

EGRESS OPENINGS

Double Hung Reverse Cottage

EGRESS OPENING														
Unit #	Egress Width		Egress Height		Egress Clear Opening		Floor To Clear Opening*		Vent		DLO		Check Rail Height	
	Inches	(mm)	Inches	(mm)	Sq. Ft.	(cm ²)	Inches	(mm)	Sq. Ft.	(cm ²)	Sq. Ft.	(cm ²)	Inches	(mm)
1626	14 9/16	(370)	7 23/32	(196)	0.78	(725)	54 41/64	(1388)	0.78	(725)	2.41	(2235)	17 11/16	(449)
1630	14 9/16	(370)	10 1/8	(257)	1.02	(951)	48 41/64	(1236)	1.02	(951)	3.03	(2818)	21 9/32	(541)
1636	14 9/16	(370)	12 33/64	(318)	1.27	(1176)	42 41/64	(1083)	1.27	(1176)	3.66	(3402)	24 7/8	(632)
1640	14 9/16	(370)	14 59/64	(379)	1.51	(1402)	36 41/64	(931)	1.51	(1402)	4.29	(3985)	28 31/64	(723)
1646	14 9/16	(370)	17 5/16	(440)	1.75	(1627)	30 41/64	(778)	1.75	(1627)	4.92	(4569)	32 5/64	(815)
1650	14 9/16	(370)	19 23/32	(501)	1.99	(1852)	24 41/64	(626)	1.99	(1852)	5.55	(5152)	35 11/16	(906)
1656	14 9/16	(370)	22 13/64	(564)	2.25	(2086)	18 41/64	(474)	2.25	(2086)	6.16	(5722)	39 3/16	(995)
2026	20 9/16	(522)	7 23/32	(196)	1.10	(1024)	54 41/64	(1388)	1.10	(1024)	3.55	(3302)	17 11/16	(449)
2030	20 9/16	(522)	10 1/8	(257)	1.44	(1342)	48 41/64	(1236)	1.44	(1342)	4.48	(4165)	21 9/32	(541)
2036	20 9/16	(522)	12 33/64	(318)	1.79	(1661)	42 41/64	(1083)	1.79	(1661)	5.41	(5027)	24 7/8	(632)
2040	20 9/16	(522)	14 59/64	(379)	2.13	(1979)	36 41/64	(931)	2.13	(1979)	6.34	(5889)	28 31/64	(723)
2046	20 9/16	(522)	17 5/16	(440)	2.47	(2297)	30 41/64	(778)	2.47	(2297)	7.27	(6751)	32 5/64	(815)
2050	20 9/16	(522)	19 23/32	(501)	2.82	(2616)	24 41/64	(626)	2.82	(2616)	8.19	(7613)	35 11/16	(906)
2056	20 9/16	(522)	22 13/64	(564)	3.17	(2946)	18 41/64	(474)	3.17	(2946)	9.10	(8456)	39 3/16	(995)
2626	26 9/16	(675)	7 23/32	(196)	1.42	(1323)	54 41/64	(1388)	1.42	(1323)	4.70	(4370)	17 11/16	(449)
2630	26 9/16	(675)	10 1/8	(257)	1.87	(1734)	48 41/64	(1236)	1.87	(1734)	5.93	(5511)	21 9/32	(541)
2636	26 9/16	(675)	12 33/64	(318)	2.31	(2145)	42 41/64	(1083)	2.31	(2145)	7.16	(6652)	24 7/8	(632)
2640	26 9/16	(675)	14 59/64	(379)	2.75	(2557)	36 41/64	(931)	2.75	(2557)	8.39	(7793)	28 31/64	(723)
2646	26 9/16	(675)	17 5/16	(440)	3.19	(2968)	30 41/64	(778)	3.19	(2968)	9.62	(8933)	32 5/64	(815)
2650	26 9/16	(675)	19 23/32	(501)	3.64	(3379)	24 41/64	(626)	3.64	(3379)	10.84	(10074)	35 11/16	(906)
2656	26 9/16	(675)	22 13/64	(564)	4.10	(3806)	18 41/64	(474)	4.10	(3806)	12.04	(11190)	39 3/16	(995)
2826	28 9/16	(725)	7 23/32	(196)	1.53	(1422)	54 41/64	(1388)	1.53	(1422)	5.09	(4726)	17 11/16	(449)
2830	28 9/16	(725)	10 1/8	(257)	2.01	(1865)	48 41/64	(1236)	2.01	(1865)	6.41	(5960)	21 9/32	(541)
2836	28 9/16	(725)	12 33/64	(318)	2.48	(2307)	42 41/64	(1083)	2.48	(2307)	7.74	(7193)	24 7/8	(632)
2840	28 9/16	(725)	14 59/64	(379)	2.96	(2749)	36 41/64	(931)	2.96	(2749				

Sliding Patio Door

EGRESS OPENING											
Unit #	Egress Width		Egress Height		Egress Clear Opening		Vent		DLO		
	Inches	(mm)	Inches	(mm)	Sq. Ft.	(cm ²)	Sq. Ft.	(cm ²)	Sq. Ft.	(cm ²)	
5068	24 1/16	(611)	75 17/64	(1912)	12.58	(11688)	12.58	(11688)	25.16	(23376)	
50610	24 1/16	(611)	77 17/64	(1963)	12.92	(11999)	12.92	(11999)	25.86	(24021)	
5080	24 1/16	(611)	91 17/64	(2318)	15.26	(14173)	15.26	(14173)	30.72	(28536)	
51068	29 5/16	(745)	75 17/64	(1912)	15.33	(14238)	15.33	(14238)	30.45	(28287)	
6068	30 1/16	(764)	75 17/64	(1912)	15.72	(14602)	15.72	(14602)	31.20	(28989)	
60610	30 1/16	(764)	77 17/64	(1963)	16.14	(14990)	16.14	(14990)	32.06	(29789)	
6080	30 1/16	(764)	91 17/64	(2318)	19.06	(17706)	19.06	(17706)	38.09	(35387)	
6068	**	32 5/32	(817)	75 17/64	(1912)	16.81	(15616)	16.81	(15616)	31.20	(28989)
60610	**	32 5/32	(817)	77 17/64	(1963)	17.26	(16031)	17.26	(16031)	32.06	(29789)
6080	**	32 5/32	(817)	91 17/64	(2318)	20.38	(18935)	20.38	(18935)	38.09	(35387)
8068	42 1/16	(1069)	75 17/64	(1912)	21.99	(20430)	21.99	(20430)	43.29	(40214)	
80610	42 1/16	(1069)	77 17/64	(1963)	22.57	(20972)	22.57	(20972)	44.48	(41323)	
8080	42 1/16	(1069)	91 17/64	(2318)	26.66	(24772)	26.66	(24772)	52.84	(49089)	
9068	30 1/16	(764)	75 17/64	(1912)	15.72	(14602)	15.72	(14602)	31.20	(28989)	
90610	30 1/16	(764)	77 17/64	(1963)	16.14	(14990)	16.14	(14990)	32.06	(29789)	
9080	30 1/16	(764)	91 17/64	(2318)	19.06	(17706)	19.06	(17706)	38.09	(35387)	

E These units meet National Egress Codes requiring 5.7 SF clear opening, 20" clear width, and 24" clear height, not to exceed a floor to sill height of 44". Code restrictions may vary depending on local building codes.

** Applies to Sliding Patio Doors with optional field applied Slim Handle (Net Clear Opening Handle).

Units may optionally include a window opening control device tested to ASTM F2090-10, which can be released from the inside without the use of a key, tool, special knowledge, or force greater than that required for normal unit operation.

For further details and drawings visit the 'Technical Specifications' section at Marvin.com.

EGRESS OPENINGS

Glider

EGRESS OPENING														
Unit #		Egress Width		Egress Height		Egress Clear Opening		Floor To Clear Opening*		Venting		DLO		
		Inches	(mm)	Inches	(mm)	Sq. Ft.	(cm ²)	Sq. Ft.	(cm ²)	Sq. Ft.	(cm ²)	Sq. Ft.	(cm ²)	
2616	XO,OX	11 13/16	(300)	13 41/64	(346)	1.10	(1024)	66 41/64	(1693)	1.10	(1024)	1.97	(1833)	
2620	XO,OX	11 13/16	(300)	19 41/64	(499)	1.59	(1482)	60 41/64	(1540)	1.59	(1482)	2.92	(2709)	
2626	XO,OX	11 13/16	(300)	25 41/64	(651)	2.09	(1939)	54 41/64	(1388)	2.09	(1939)	3.86	(3584)	
2630	XO,OX	11 13/16	(300)	31 41/64	(804)	2.58	(2396)	48 41/64	(1236)	2.58	(2396)	4.80	(4460)	
2636	XO,OX	11 13/16	(300)	37 41/64	(956)	3.07	(2853)	42 41/64	(1083)	3.07	(2853)	5.74	(5335)	
2640	XO,OX	11 13/16	(300)	43 41/64	(1108)	3.56	(3310)	36 41/64	(931)	3.56	(3310)	6.69	(6211)	
2646	XO,OX	11 13/16	(300)	49 41/64	(1261)	4.05	(3767)	30 41/64	(778)	4.05	(3767)	7.63	(7087)	
2650	XO,OX	11 13/16	(300)	55 41/64	(1413)	4.55	(4224)	24 41/64	(626)	4.55	(4224)	8.57	(7962)	
3016	XO,OX	14 13/16	(376)	13 41/64	(346)	1.39	(1288)	66 41/64	(1693)	1.39	(1288)	2.50	(2319)	
3020	XO,OX	14 13/16	(376)	19 41/64	(499)	2.00	(1862)	60 41/64	(1540)	2.00	(1862)	3.69	(3427)	
3026	XO,OX	14 13/16	(376)	25 41/64	(651)	2.62	(2435)	54 41/64	(1388)	2.62	(2435)	4.88	(4535)	
3030	XO,OX	14 13/16	(376)	31 41/64	(804)	3.24	(3008)	48 41/64	(1236)	3.24	(3008)	6.07	(5643)	
3036	XO,OX	14 13/16	(376)	37 41/64	(956)	3.85	(3581)	42 41/64	(1083)	3.85	(3581)	7.27	(6751)	
3040	XO,OX	14 13/16	(376)	43 41/64	(1108)	4.47	(4154)	36 41/64	(931)	4.47	(4154)	8.46	(7858)	
3046	XO,OX	14 13/16	(376)	49 41/64	(1261)	5.09	(4728)	30 41/64	(778)	5.09	(4728)	9.65	(8966)	
3050	XO,OX	14 13/16	(376)	55 41/64	(1413)	5.71	(5301)	24 41/64	(626)	5.71	(5301)	10.84	(10074)	
3616	XO,OX	17 13/16	(452)	13 41/64	(346)	1.67	(1552)	66 41/64	(1693)	1.67	(1552)	3.02	(2805)	
3620	XO,OX	17 13/16	(452)	19 41/64	(499)	2.41	(2242)	60 41/64	(1540)	2.41	(2242)	4.46	(4145)	
3626	XO,OX	17 13/16	(452)	25 41/64	(651)	3.15	(2931)	54 41/64	(1388)	3.15	(2931)	5.90	(5486)	
3630	XO,OX	17 13/16	(452)	31 41/64	(804)	3.90	(3620)	48 41/64	(1236)	3.90	(3620)	7.35	(6826)	
3636	XO,OX	17 13/16	(452)	37 41/64	(956)	4.64	(4310)	42 41/64	(1083)	4.64	(4310)	8.79	(8166)	
3640	XO,OX	17 13/16	(452)	43 41/64	(1108)	5.38	(4999)	36 41/64	(931)	5.38	(4999)	10.23	(9506)	
3646	XO,OX	17 13/16	(452)	49 41/64	(1261)	6.12	(5688)	30 41/64	(778)	6.12	(5688)	11.67	(10846)	
3650	XO,OX	17 13/16	(452)	55 41/64	(1413)	6.86	(6378)	24 41/64	(626)	6.86	(6378)	13.12	(12186)	
4016	XO,OX	20 13/16	(529)	13 41/64	(346)	1.95	(1816)	66 41/64	(1693)	1.95	(1816)	3.54	(3292)	
4020	XO,OX	20 13/16	(529)	19 41/64	(499)	2.82	(2622)	60 41/64	(1540)	2.82	(2622)	5.24	(4864)	
4026	XO,OX	20 13/16	(529)	25 41/64	(651)	3.69	(3427)	54 41/64	(1388)	3.69	(3427)	6.93	(6436)	
4030	XO,OX	20 13/16	(529)	31 41/64	(804)	4.56	(4232)	48 41/64	(1236)	4.56	(4232)	8.62	(8009)	
4036	XO,OX	20 13/16	(529)	37 41/64	(956)	5.42	(5038)	42 41/64	(1083)	5.42	(5038)	10.31	(9581)	
4040	XO,OX	E	20 13/16	(529)	43 41/64	(1108)	6.29	(5843)	36 41/64	(931)	6.29	(5843)	12.01	(11153)
4046	XO,OX	E	20 13/16	(529)	49 41/64	(1261)	7.16	(6649)	30 41/64	(778)	7.16	(6649)	13.70	(12726)
4050	XO,OX	E	20 13/16	(529)	55 41/64	(1413)	8.02	(7454)	24 41/64	(626)	8.02	(7454)	15.39	(14298)
4616	XO,OX	23 13/16	(605)	13 41/64	(346)	2.24	(2080)	66 41/64	(1693)	2.24	(2080)	4.07	(3778)	
4620	XO,OX	23 13/16	(605)	19 41/64	(499)	3.23	(3002)	60 41/64	(1540)	3.23	(3002)	6.01	(5582)	
4626	XO,OX	23 13/16	(605)	25 41/64	(651)	4.22	(3923)	54 41/64	(1388)	4.22	(3923)	7.95	(7387)	
4630	XO,OX	23 13/16	(605)	31 41/64	(804)	5.21	(4845)	48 41/64	(1236)	5.21	(4845)	9.89	(9192)	
4636	XO,OX	E	23 13/16	(605)	37 41/64	(956)	6.21	(5766)	42 41/64	(1083)	6.21	(5766)	11.84	(10996)
4640	XO,OX	E	23 13/16	(605)	43 41/64	(1108)	7.20	(6688)	36 41/64	(931)	7.20	(6688)	13.78	(12801)
4646	XO,OX	E	23 13/16	(605)	49 41/64	(1261)	8.19	(7610)	30 41/64	(778)	8.19	(7610)	15.72	(14606)
4650	XO,OX	E	23 13/16	(605)	55 41/64	(1413)	9.18	(8531)	24 41/64	(626)	9.18	(8531)	17.66	(16410)
5016	XO,OX	26 13/16	(681)	13 41/64	(346)	2.52	(2344)	66 41/64	(1693)	2.52	(2344)	4.59	(4264)	
5020	XO,OX	26 13/16	(681)	19 41/64	(499)	3.64	(3382)	60 41/64	(1540)	3.64	(3382)	6.78	(6301)	
5026	XO,OX	26 13/16	(681)	25 41/64	(651)	4.76	(4419)	54 41/64	(1388)	4.76	(4419)	8.97	(8338)	
5030	XO,OX	E	26 13/16	(681)	31 41/64	(804)	5.87	(5457)	48 41/64	(1236)	5.87	(5457)	11.17	(10375)
5036	XO,OX	E	26 13/16	(681)	37 41/64	(956)	6.99	(6495)	42 41/64	(1083)	6.99	(6495)	13.36	(12412)
5040	XO,OX	E	26 13/16	(681)	43 41/64	(1108)	8.11	(7532)	36 41/64	(931)	8.11	(7532)	15.55	(14448)
5046	XO,OX	E	26 13/16	(681)	49 41/64	(1261)	9.22	(8570)	30 41/64	(778)	9.22	(8570)	17.74	(16485)
5050	XO,OX	E	26 13/16	(681)	55 41/64	(1413)	10.34	(9608)	24 41/64	(626)	10.34	(9608)	19.94	(18522)
6016	XO,OX	32 13/16	(833)	13 41/64	(346)	3.09	(2872)	66 41/64	(1693)	3.09	(2872)	5.64	(5236)	
6020	XO,OX	32 13/16	(833)	19 41/64	(499)	4.46	(4142)	60 41/64	(1540)	4.46	(4142)	8.33	(7738)	
6026	XO,OX	E	32 13/16	(833)	25 41/64	(651)	5.82	(5412)	54 41/64	(1388)	5.82	(5412)	11.02	(10239)
6030	XO,OX	E	32 13/16	(833)	31 41/64	(804)	7.19	(6682)	48 41/64	(1236)	7.19	(6682)	13.71	(12741)
6036	XO,OX	E	32 13/16	(833)	37 41/64	(956)	8.56	(7952)	42 41/64	(1083)	8.56	(7952)	16.41	(15242)
6040	XO,OX	E	32 13/16	(833)	43 41/64	(1108)	9.93	(9222)	36 41/64	(931)	9.93	(9222)	19.10	(17743)
6046	XO,OX	E	32 13/16	(833)	49 41/64	(1261)	11.29	(10492)	30 41/64	(778)	11.29	(10492)	21.79	(20245)
6050	XO,OX	E	32 13/16	(833)	55 41/64	(1413)	12.66	(11762)	24 41/64	(626)	12.66	(11762)	24.48	(22746)
6016	XOX	14 13/16	(376)	13 41/64	(346)	1.39	(1289)	66 41/64	(1693)	2.77	(2578)	5.47	(5086)	
6020	XOX	14 13/16	(376)	19 41/64	(499)	2.00	(1862)	60 41/64	(1540)	4.01	(3725)	8.09	(7516)	
6026	XOX	14 13/16	(376)	25 41/64	(651)	2.62	(2436)	54 41/64	(1388)	5.24	(4872)	10.71	(9946)	
6030	XOX	14 13/16	(376)	31 41/64	(804)	3.24	(3009)	48 41/64	(1236)	6.48	(6019)	13.32	(12375)	
6036	XOX	14 13/16	(376)	37 41/64	(956)	3.86	(3583)	42 41/64	(1083)	7.71	(7166)	15.94	(14805)	
6040	XOX	14 13/16	(376)	43 41/64	(1108)	4.47	(4156)	36 41/64	(931)	8.95	(8313)	18.55	(17235)	
6046	XOX	14 13/16	(376)	49 41/64	(1261)	5.09	(4730)	30 41/64	(778)	10.18	(9460)	21.17	(19665)	
6050	XOX	14 13/16	(376)	55 41/64	(1413)	5.71	(5303)	24 41/64	(626)	11.42	(10607)	23.78	(22094)	
7016	XOX	17 13/16	(453)	13 41/64	(346)	1.67	(1553)	66 41/64	(1693)	3.34	(3106)	6.52	(6059)	
7020	XOX	17 13/16	(453)	19 41/64	(499)	2.41	(2242)	60 41/64	(1540)	4.83	(4485)	9.64	(8953)	
7026	XOX	17 13/16	(453)	25 41/										

ALTITUDE GUIDELINES

Marvin recommends the maximum altitude limitation for its seal insulated glass units. These limits do not account for glass deflection which may take on a pillowed appearance below these elevations. The limits may be affected by site, location, temperature and/or divided lites. Marvin does not recommend the use of IG units in excess of these specified guidelines. These limitations apply to Marvin units and should not be interpreted as an industry standard.

Casement

ALTITUDE LIMITS (FEET)

	UNIT SIZE	16	20	26	30
20	Annealed	4000	5000	5500	5500
	Tempered	5500	8000	9000	9000
26	Annealed	4000	5500	7000	7000
	Tempered	7000	9000	10000	10000
30	Annealed	4000	5500	7000	9000
	Tempered	7000	9000	10000	10000
36	Annealed	4000	6000	7500	9000
	Tempered	7000	10000	10000	10000
40	Annealed	4000	6000	7500	9500
	Tempered	7000	10000	10000	10000
46	Annealed	4000	6000	8000	9500
	Tempered	7000	10000	10000	10000
50	Annealed	4000	6000	8000	10000
	Tempered	7000	10000	10000	10000
56	Annealed	4000	6000	8000	10000
	Tempered	7000	10000	10000	10000
60	Annealed	4000	6000	8000	10000
	Tempered	7000	10000	10000	10000
66	Annealed	4000	6000	8000	10000
	Tempered	7000	10000	10000	10000
70	Annealed	4000	6000	8000	10000
	Tempered	7000	10000	10000	10000

Casement STC/OITC

ALTITUDE LIMITS (FEET)

	UNIT SIZE	16	20	26	30
20	Annealed	3000	4000	4000	4000
	Tempered	4500	6000	8000	8000
26	Annealed	3000	4000	6000	6000
	Tempered	5000	8000	10000	10000
30	Annealed	3000	4000	6000	7000
	Tempered	5000	8000	10000	10000
36	Annealed	3000	4000	6500	7000
	Tempered	5000	10000	10000	10000
40	Annealed	3000	4000	6500	8000
	Tempered	5000	10000	10000	10000
46	Annealed	3000	4000	7000	8000
	Tempered	5000	10000	10000	10000
50	Annealed	3000	4000	7000	9000
	Tempered	5000	10000	10000	10000
56	Annealed	3000	4000	7000	9000
	Tempered	5000	10000	10000	10000
60	Annealed	3000	4000	7000	9000
	Tempered	5000	10000	10000	10000
66	Annealed	3000	5000	7000	N/A
	Tempered	6000	10000	10000	N/A
70	Annealed	3000	5000	N/A	N/A
	Tempered	6000	10000	N/A	N/A

Awning

ALTITUDE LIMITS (FEET)

	UNIT SIZE	16	20	26	30	36	40	46	50
16	Annealed	4000	4000	4000	4000	4000	4000	4000	4000
	Tempered	4000	5500	7000	7000	7000	7000	7000	7000
20	Annealed	4000	5000	5500	5500	6000	6000	5000	6000
	Tempered	5500	8000	9000	9000	10000	10000	8000	10000
26	Annealed	4000	5500	7000	7000	7500	7500	7000	8000
	Tempered	7000	9000	10000	10000	10000	10000	10000	10000
30	Annealed	4000	5500	7000	9000	9000	9500	9000	10000
	Tempered	7000	9000	10000	10000	10000	10000	10000	10000
36	Annealed	4000	6000	7500	9000	10000	10000	10000	10000
	Tempered	7000	10000	10000	10000	10000	10000	10000	10000
40	Annealed	4000	6000	7500	9500	10000	10000	10000	10000
	Tempered	7000	10000	10000	10000	10000	10000	10000	10000

Awning STC/OITC

ALTITUDE LIMITS (FEET)

	UNIT SIZE	16	20	26	30	36	40	46	50
16	Annealed	3000	3000	3000	3000	3000	3000	3000	3000
	Tempered	4000	4500	5000	5000	5000	6000	6000	6000
20	Annealed	3000	4000	4000	4000	4000	4000	5000	4000
	Tempered	4500	6000	8000	8000	10000	10000	10000	10000
26	Annealed	3000	4000	6000	6000	6500	6500	6000	7000
	Tempered	5000	8000	10000	10000	10000	10000	10000	10000
30	Annealed	3000	4000	6000	7000	7000	8000	8000	9000
	Tempered	5000	8000	10000	10000	10000	10000	10000	10000
36	Annealed	3000	4000	6500	7000	9000	9000	10000	9500
	Tempered	5000	10000	10000	10000	10000	10000	10000	10000
40	Annealed	3000	4000	6500	8000	9000	10000	10000	10000
	Tempered	5000	10000	10000	10000	10000	10000	10000	10000

Marvin provides these elevation guidelines as a convenience to our customers. Marvin does not recommend installation above the elevation guidelines, and products installed above such elevations are not warranted. A variety of factors, including ambient temperature, altitude, and other conditions outside Marvin's control may cause glass deflection, distortion, or an increase in convexity of the insulating glass units. Deflection, distortion, and increased convexity are not considered product defects and are not covered under Marvin's general warranty; capillary tubes may minimize these effects. Essential does not warrant the amount or percentage of argon or other inert gas present in insulating glass at any time after manufacture. Inert gas dissipates over time, and may be ineffective in products manufactured with capillary tubes. Thermal efficiencies vary with the application of the product. Marvin does not warrant that a specific level of thermal efficiency will be achieved by inert gas, low emissivity coatings, or other product features. Determining the suitability and compliance with local or other applicable building codes or standards, of all building components, including the use of any Marvin product, and the design and installation of any flashing or sealing system, is the responsibility of the buyer, user, architect, contractor, installer, and/or other construction professional. Marvin will not be liable for any problem or damage relating to inappropriate or faulty building design or construction, maintenance, installation, or selection of products. Marvin does not warrant any product's compliance with local or other applicable building codes or standards, or its suitability for use in connection with a project seeking third party certification to any standard.

ALTITUDE GUIDELINES

Marvin recommends the maximum altitude limitation for its seal insulated glass units. These limits do not account for glass deflection which may take on a pillowed appearance below these elevations. The limits may be affected by site, location, temperature and/or divided lites. Marvin does not recommend the use of IG units in excess of these specified guidelines. These limitations apply to Marvin units and should not be interpreted as an industry standard.

Casement Picture

ALTITUDE LIMITS (FEET)

	UNIT SIZE	16	20	26	30	36	40	46	50	60
20	Annealed	4000	5000	5500	5500	6000	6000	5000	5000	6000
	Tempered	5500	8000	9000	9000	10000	10000	8000	10000	10000
26	Annealed	4000	5500	7000	7000	7500	7500	7000	8000	8000
	Tempered	7000	9000	10000	10000	10000	10000	10000	10000	10000
30	Annealed	4000	5500	7000	9000	9000	9500	9000	10000	10000
	Tempered	7000	9000	10000	10000	10000	10000	10000	10000	10000
36	Annealed	4000	6000	7500	9000	10000	10000	10000	10000	10000
	Tempered	7000	10000	10000	10000	10000	10000	10000	10000	10000
40	Annealed	4000	6000	7500	9500	10000	10000	10000	10000	10000
	Tempered	7000	10000	10000	10000	10000	10000	10000	10000	10000
46	Annealed	4000	6000	8000	9500	10000	10000	10000	10000	10000
	Tempered	7000	10000	10000	10000	10000	10000	10000	10000	10000
50	Annealed	4000	6000	8000	10000	10000	10000	10000	10000	10000
	Tempered	7000	10000	10000	10000	10000	10000	10000	10000	10000
56	Annealed	4000	6000	8000	10000	10000	10000	10000	10000	10000
	Tempered	7000	10000	10000	10000	10000	10000	10000	10000	10000
60	Annealed	4000	6000	8000	10000	10000	10000	10000	10000	10000
	Tempered	7000	10000	10000	10000	10000	10000	10000	10000	10000
66	Annealed	4000	6000	8000	10000	10000	N/A	N/A	N/A	N/A
	Tempered	7000	10000	10000	10000	10000	N/A	N/A	N/A	N/A
70	Annealed	4000	6000	8000	10000	10000	N/A	N/A	N/A	N/A
	Tempered	7000	10000	10000	10000	10000	N/A	N/A	N/A	N/A

Casement Transom

ALTITUDE LIMITS (FEET)

	UNIT SIZE	16	20	26	30	36	40	46	50	60
10	Annealed	4000	4000	4000	4000	4000	4000	4000	N/A	N/A
	Tempered	7000	7000	7000	7000	7000	7000	7000	N/A	N/A
16	Annealed	4000	4000	4000	4000	4000	4000	4000	N/A	N/A
	Tempered	4000	5500	7000	7000	7000	7000	7000	N/A	N/A
20	Annealed	4000	5000	5500	5500	6000	6000	5000	6000	6000
	Tempered	5500	8000	9000	9000	10000	10000	8000	10000	10000

Casement Picture STC/OITC

ALTITUDE LIMITS (FEET)

	UNIT SIZE	16	20	26	30	36	40	46	50	60
20	Annealed	3000	4000	4000	4000	4000	4000	5000	4000	4000
	Tempered	4500	6000	8000	8000	10000	10000	10000	10000	10000
26	Annealed	3000	4000	6000	6000	6500	6500	6000	7000	7000
	Tempered	5000	8000	10000	10000	10000	10000	10000	10000	10000
30	Annealed	3000	4000	6000	7000	7000	8000	8000	9000	9000
	Tempered	5000	8000	10000	10000	10000	10000	10000	10000	10000
36	Annealed	3000	4000	6500	7000	9000	9000	10000	9500	10000
	Tempered	5000	10000	10000	10000	10000	10000	10000	10000	10000
40	Annealed	3000	4000	6500	8000	9000	10000	10000	10000	N/A
	Tempered	5000	10000	10000	10000	10000	10000	10000	10000	N/A
46	Annealed	3000	4000	7000	8000	9500	10000	10000	10000	N/A
	Tempered	5000	10000	10000	10000	10000	10000	10000	10000	N/A
50	Annealed	3000	4000	7000	9000	9500	10000	N/A	N/A	N/A
	Tempered	5000	10000	10000	10000	10000	10000	10000	10000	N/A
56	Annealed	3000	4000	7000	9000	9500	10000	N/A	N/A	N/A
	Tem									

Single Hung/Double Hung

ALTITUDE LIMITS (FEET)

UNIT SIZE	16	20	26	28	30	36	40
20	Annealed	4000	4000	4000	4000	4000	4000
	Tempered	4000	5000	5000	6000	6000	6000
26	Annealed	4000	4000	4000	4000	4000	4000
	Tempered	5000	6000	7000	7000	8000	9000
30	Annealed	4000	5000	5000	5000	5000	5000
	Tempered	6000	7000	9000	9000	10000	10000
36	Annealed	4000	5000	5000	6000	6000	6000
	Tempered	6000	8000	10000	10000	10000	10000
40	Annealed	4000	6000	6000	6000	7000	7000
	Tempered	7000	9000	10000	10000	10000	10000
46	Annealed	4000	6000	7000	7000	8000	8000
	Tempered	7000	10000	10000	10000	10000	10000
50	Annealed	4000	6000	8000	8000	9000	9000
	Tempered	8000	10000	10000	10000	10000	10000
56	Annealed	4000	6000	8000	8000	9000	10000
	Tempered	8000	10000	10000	10000	10000	10000
60	Annealed	4000	6000	8000	8000	9000	10000
	Tempered	9000	10000	10000	10000	10000	10000
66	Annealed	4000	6000	8000	9000	10000	10000
	Tempered	9000	10000	10000	10000	10000	10000

Single Hung/Double Hung STC/OITC

ALTITUDE LIMITS (FEET)

UNIT SIZE	16	20	26	28	30	36	40
20	Annealed	3000	3000	3000	3000	3000	3000
	Tempered	4000	4000	5000	5000	5000	5000
26	Annealed	3000	3000	3000	3000	3000	3000
	Tempered	4000	5000	6000	6000	7000	7000
30	Annealed	3000	4000	4000	4000	4000	4000
	Tempered	5000	6000	7000	7000	8000	9000
36	Annealed	3000	4000	4000	4000	5000	5000
	Tempered	5000	7000	8000	9000	10000	10000
40	Annealed	3000	4000	5000	5000	5000	6000
	Tempered	6000	8000	10000	10000	10000	10000
46	Annealed	3000	5000	6000	6000	6000	7000
	Tempered	6000	9000	10000	10000	10000	10000
50	Annealed	3000	5000	6000	7000	7000	7000
	Tempered	7000	9000	10000	10000	10000	10000
56	Annealed	3000	5000	6000	7000	8000	8000
	Tempered	7000	10000	10000	10000	10000	10000
60	Annealed	3000	5000	7000	7000	8000	9000
	Tempered	7000	10000	10000	10000	10000	10000
66	Annealed	3000	5000	7000	7000	8000	10000
	Tempered	8000	10000	10000	10000	10000	10000

Double Hung Picture

ALTITUDE LIMITS (FEET)

UNIT SIZE	16	20	26	28	30	36	40	50
20	Annealed	4000	5000	6000	6000	6000	6000	6000
	Tempered	7000	9000	10000	10000	10000	10000	10000
26	Annealed	4000	6000	7000	8000	8000	8000	9000
	Tempered	8000	10000	10000	10000	10000	10000	10000
30	Annealed	4000	6000	8000	8000	9000	10000	10000
	Tempered	8000	10000	10000	10000	10000	10000	10000
36	Annealed	4000	6000	8000	9000	10000	10000	10000
	Tempered	9000	10000	10000	10000	10000	10000	10000
40	Annealed	4000	6000	8000	9000	10000	10000	10000
	Tempered	10000	10000	10000	10000	10000	10000	10000
46	Annealed	4000	6000	8000	9000	10000	10000	10000
	Tempered	10000	10000	10000	10000	10000	10000	10000
50	Annealed	4000	6000	9000	9000	10000	10000	10000
	Tempered	10000	10000	10000	10000	10000	10000	10000
56	Annealed	4000	6000	8000	9000	10000	10000	10000
	Tempered	10000	10000	10000	10000	10000	10000	10000
60	Annealed	4000	6000	8000	9000	10000	10000	10000
	Tempered	10000	10000	10000	10000	10000	10000	10000

Double Hung Picture STC/OITC

ALTITUDE LIMITS (FEET)

UNIT SIZE	16	20	26	28	30	36	40	50
20	Annealed	3000	4000	5000	5000	5000	5000	5000
	Tempered	5000	7000	9000	9000	10000	10000	10000
26	Annealed	3000	5000	6000	6000	6000	7000	7000
	Tempered	6000	9000	10000	10000	10000	10000	10000
30	Annealed	3000	5000	6000	7000	8000	9000	9000
	Tempered	7000	10000	10000	10000	10000	10000	10000
36	Annealed	3000	5000	7000	7000	8000	10000	10000
	Tempered	8000	10000	10000	10000	10000	10000	10000
40	Annealed	3000	5000	7000	7000	9000	10000	N/A
	Tempered	8000	10000	10000	10000	10000	10000	N/A
46	Annealed	3000	5000	7000	8000	9000	10000	N/A
	Tempered	9000	10000	10000	10000	10000	10000	N/A
50	Annealed	3000	5000	7000	8000	9000	10000	N/A
	Tempered	9000	10000	10000	10000	10000	10000	N/A
56	Annealed	3000	5000	N/A	N/A	9000	N/A	N/A
	Tempered	9000	10000	N/A	N/A	10000	N/A	N/A
60	Annealed	3000	5000	N/A	N/A	N/A	N/A	N/A
	Tempered	9000	10000	N/A	N/A	N/A	N/A	N/A

ALTITUDE GUIDELINES

Glider

ALTITUDE LIMITS (FEET)

UNIT SIZE	26	30	36	40	46	50	60
16	Annealed	4000	4000	4000	4000	4000	4000
	Tempered	5000	6000	6000	7000	7000	8000
20	Annealed	4000	5000	5000	6000	6000	6000
	Tempered	6000	7000	8000	9000	10000	10000
26	Annealed	4000	5000	5000	6000	7000	8000
	Tempered	7000	9000	10000	10000	10000	10000
30	Annealed	4000	5000	6000	7000	7000	8000
	Tempered	8000	10000	10000	10000	10000	10000
36	Annealed	4000	5000	6000	7000	8000	9000
	Tempered	8000	10000	10000	10000	10000	10000
40	Annealed	4000	5000	6000	7000	8000	9000
	Tempered	9000	10000	10000	10000	10000	10000
46	Annealed	4000	5000	6000	7000	8000	9000
	Tempered	9000	10000	10000	10000	10000	10000
50	Annealed	4000	5000	6000	7000	8000	9000
	Tempered	9000	10000	10000	10000	10000	10000

Glider STC/OITC

ALTITUDE LIMITS (FEET)

UNIT SIZE	26	30	36	40	46	50	60
16	Annealed	3000	3000	3000	3000	3000	3000
	Tempered	4000	5000	5000	6000	6000	7000
20	Annealed	3000	4000	4000	4000	5000	5000
	Tempered	5000	6000	7000	8000	9000	10000
26	Annealed	3000	4000	4000	5000	6000	7000
	Tempered	6000	7000	8000	10000	10000	10000
30	Annealed	3000	4000	5000	5000	6000	7000
	Tempered	6000	8000	10000	10000	10000	10000
36	Annealed	3000	4000	5000	5000	6000	7000
	Tempered	7000	9000	10000	10000	10000	10000
40	Annealed	3000	4000	5000	6000	7000	9000
	Tempered	7000	10000	10000	10000	10000	10000
46	Annealed	3000	4000	5000	6000	7000	9000
	Tempered	8000	10000	10000	10000	10000	10000
50	Annealed	3000	4000	5000	6000	7000	9000
	Tempered	8000	10000	10000	10000	10000	10000

Glider Triple Sash Operating Sash

ALTITUDE LIMITS (FEET)

UNIT SIZE	60	70	80	
16	Annealed	4000	4000	4000
	Tempered	6000	6000	7000
20	Annealed	5000	5000	6000
	Tempered	7000	8000	9000
26	Annealed	5000	5000	6000
	Tempered	9000	10000	10000
30	Annealed	5000	6000	7000
	Tempered	10000	10000	10000
36	Annealed	5000	6000	7000
	Tempered	10000	10000	10000
40	Annealed	5000	6000	7000
	Tempered	10000	10000	10000
46	Annealed	5000	6000	7000
	Tempered	10000	10000	10000
50	Annealed	5000	6000	7000
	Tempered	10000	10000	10000

Glider Triple Sash Operating Sash STC/OITC

ALTITUDE LIMITS (FEET)

UNIT SIZE	60	70	80	
16	Annealed	3000	3000	3000
	Tempered	5000	5000	5000
20	Annealed	4000	4000	4000
	Tempered	6000	6000	7000
26	Annealed	4000	4000	5000
	Tempered	7000	8000	9000
30	Annealed	4000	5000	5000
	Tempered	8000	10000	10000
36	Annealed	4000	5000	5000
	Tempered	9000	10000	10000
40	Annealed			

ALTITUDE GUIDELINES

Double Hung Transom

ALTITUDE LIMITS (FEET)									
UNIT SIZE	16	20	26	28	30	36	40	50	
10	Annealed	4000	4000	4000	4000	4000	4000	4000	4000
	Tempered	4000	5000	5000	5000	5000	5000	5000	5000
16	Annealed	4000	4000	4000	4000	4000	4000	4000	4000
	Tempered	5000	7000	8000	8000	8000	9000	10000	10000
20	Annealed	N/A	5000	6000	6000	6000	6000	6000	6000
	Tempered	N/A	9000	10000	10000	10000	10000	10000	10000

Sliding Patio Door

ALTITUDE LIMITS (FEET)					
UNIT SIZE	50	510	60	80	90
68	Annealed	N/A	N/A	N/A	N/A
	Tempered	10000	10000	10000	10000
610	Annealed	N/A	N/A	N/A	N/A
	Tempered	10000	N/A	10000	10000
80	Annealed	N/A	N/A	N/A	N/A
	Tempered	10000	N/A	10000	10000

Direct Glaze over Sliding Patio Door

ALTITUDE LIMITS (FEET)					
UNIT SIZE	50	510	60	80	90
10	Annealed	3000	3000	3000	3000
	Tempered	N/A	N/A	N/A	N/A
16	Annealed	4000	4000	4000	3000
	Tempered	N/A	N/A	N/A	N/A

Direct Glaze Round Top - RT1

ALTITUDE LIMITS (FEET)										
UNIT SIZE	2613	2814	3016	3619	4020	5026	5428	6030	7036	8040
10	Annealed	3000	3000	4000	5000	5000	7000	8000	9000	10000
	Tempered	N/A	N/A	N/A	N/A	N/A	N/A	N/A	N/A	10000

Direct Glaze Round Top - RT2

ALTITUDE LIMITS (FEET)									
UNIT SIZE	26	28	30	36	40	50	54	60	
10	Annealed	5000	6000	6000	7500	8500	10000	9500	10000
	Tempered	9000	10000	10000	10000	10000	10000	10000	10000
16	Annealed	6000	7000	8000	9000	9000	10000	9500	10000
	Tempered	10000	10000	10000	10000	10000	10000	10000	10000
20	Annealed	6500	7500	8000	9000	10000	10000	10000	10000
	Tempered	10000	10000	10000	10000	10000	10000	10000	10000
26	Annealed	6500	7500	8500	9000	10000	9000	10000	10000
	Tempered	10000	10000	10000	10000	10000	10000	10000	10000
30	Annealed	7000	7500	8500	9500	10000	9000	10000	N/A
	Tempered	10000	10000	10000	10000	10000	10000	10000	N/A
36	Annealed	7000	8000	8500	9500	10000	10000	10000	N/A
	Tempered	10000	10000	10000	10000	10000	10000	10000	N/A
40	Annealed	6000	7000	9000	9500	10000	10000	10000	N/A
	Tempered	10000	10000	10000	10000	10000	10000	10000	N/A
46	Annealed	6000	7000	10000	10000	10000	10000	N/A	N/A
	Tempered	10000	10000	10000	10000	10000	10000	N/A	N/A
50	Annealed	6000	7000	10000	10000	10000	N/A	N/A	N/A
	Tempered	10000	10000	10000	10000	10000	N/A	N/A	N/A

Double Hung Transom STC/OITC

ALTITUDE LIMITS (FEET)									
UNIT SIZE	16	20	26	28	30	36	40	50	
10	Annealed	3000	3000	3000	3000	3000	3000	3000	3000
	Tempered	4000	4000	4000	4000	4000	5000	5000	5000
16	Annealed	3000	3000	3000	3000	3000	3000	3000	3000
	Tempered	4000	5000	6000	7000	7000	8000	8000	9000
20	Annealed	N/A	4000	5000	5000	5000	5000	5000	5000
	Tempered	N/A	7000	9000	9000	10000	10000	10000	10000

Sliding Patio Door STC/OITC

ALTITUDE LIMITS (FEET)					
UNIT SIZE	50	510	60	80	90
68	Annealed	N/A	N/A	N/A	N/A
	Tempered	10000	10000	10000	N/A
610	Annealed	N/A	N/A	N/A	N/A
	Tempered	10000	N/A	10000	N/A
80	Annealed	N/A	N/A	N/A	N/A
	Tempered	N/A	N/A	N/A	N/A

Direct Glaze over Sliding Patio Door STC/OITC

ALTITUDE LIMITS (FEET)				
UNIT SIZE	50	510	60	80
10	Annealed	3000	3000	3000
	Tempered	N/A	N/A	N/A
16	Annealed	4000	4000	3000
	Tempered	N/A	N/A	N/A

Direct Glaze Round Top - RT1 STC/OITC

ALTITUDE LIMITS (FEET)				
UNIT SIZE	2613	2814	3016	3619
10	Annealed	3000	3000	4000
	Tempered	NA	NA	NA

Direct Glaze Round Top - RT2 STC/OITC

ALTITUDE LIMITS (FEET)				
UNIT SIZE	26	28	30	36
10	Annealed	4000	4000	5000
	Tempered	8000	8000	9000
16	Annealed	5000	5000	6000
	Tempered	9000	10000	N/A
20	Annealed	5500	5500	6000
	Tempered	9500	10000	N/A
26	Annealed	5500	5500	6500
	Tempered	9500	10000	N/A
30	Annealed	6000	5500	6500
	Tempered	10000	10000	N/A
36	Annealed	6000	6000	6500
	Tempered	10000	10000	N/A
40	Annealed	N/A	N/A	7000
	Tempered	10000	10000	N/A
46	Annealed	N/A	N/A	N/A
	Tempered	10000	10000	N/A
50	Annealed	N/A	N/A	N/A
	Tempered	10000	10000	N/A

ALTITUDE GUIDELINES

Direct Glaze Round Top - RT6

ALTITUDE LIMITS (FEET)										
UNIT SIZE	26	28	30	36	40	50	54	60	70	80
10	Annealed	4000	4000	4000	4000	4000	4000	4000	4000	
	Tempered	5000	5000	7000	7000	7000	9000	8000	10000	
16	Annealed	4000	4000	4500	5000	6000	6000	6000	6000	
	Tempered	8000	8000	8500	10000	10000	10000	10000	10000	
20	Annealed	5000	5000	6500	6500	8000	7000	7000	8000	
	Tempered	9000	9000	10000	10000	10000	10000	10000	10000	
26	Annealed	6000	7000	8000	8000	8500	9000	10000	9000	
	Tempered	10000	10000	10000	10000	10000	10000	10000	10000	
30	Annealed	6500	7500	8000	9000	9500	9500	10000	N/A	
	Tempered	10000	10000	10000	10000	10000	10000	10000	10000	
36	Annealed	6500	7500	8500	9000	10000	10000	10000	10000	
	Tempered	10000	10000	10000	10000	10000	10000	10000	10000	
40	Annealed	7000	7500	8500	9500	10000	10000	10000	10000	
	Tempered	10000	10000	10000	10000	10000	10000	10000	10000	
46	Annealed	7000	8000	8500	9500	10000	10000	10000	N/A	
	Tempered	10000	10000	10000	10000	10000	10000	10000	N/A	
50	Annealed	6000	7000	9000	9500	10000	10000	10000	N/A	
	Tempered	10000	10000	10000	10000	10000	10000	10000	N/A	
56	Annealed	6000	7000	8000	9500	10000	10000	10000	N/A	
	Tempered	10000	10000	10000	10000	10000	10000	N/A	N/A	
60	Annealed	6000	7000	8000	10000	10000	10000	N/A	N/A	
	Tempered	10000	10000	10000	10000	10000	10000	N/A	N/A	

Direct Glaze Round Top - RT6 STC/OITC

ALTITUDE LIMITS (FEET)									
UNIT SIZE	26	28	30	36	40	50	54	60	
10	Annealed	3000	3000	3000	3000	3000	3000	3000	3000
	Tempered	4000	4000	5000	5000	6000	7000	7000	8000
16	Annealed	3000	3000	3000	4000	4000	4000	4000	N/A
	Tempered	6500	8000	6500	9000	10000	10000	10000	10000
20	Annealed	4000	4000	5000	5000	6000	6000	N/A	N/A
	Tempered	8000	8000	9500	9500	10000	10000	10000	10000
26	Annealed	5000	5000	6000	6000	6500	7500	8000	N/A
	Tempered	9000	10000	10000	10000	10000	10000	10000	N/A
30	Annealed	5500	5500	6000	8000	8000	N/A	N/A	N/A
	Tempered	9500	10000	10000	N/A	N/A	N/A	N/A	N/A
36	Annealed	5500	5500	6000	8000	9000	N/A	N/A	N/A
	Tempered	9500	10000	10000	N/A	N/A	N/A	N/A	N/A
40	Annealed	6000	5500	6500	8000	N/A	N/A	N/A	N/A
	Tempered	10000	10000	10000	N/A	N/A	N/A	N/A	N/A
46	Annealed	6000	6000	6500	N/A	N/A	N/A	N/A	N/A
	Tempered	10000	10000	10000	N/A	N/A	N/A	N/A	N/A
50	Annealed	N/A	N/A	7000	N/A	N/A	N/A	N/A	N/A
	Tempered	10000	10000	10000	N/A	N/A	N/A	N/A	N/A
56	Annealed	N/A	N/A	N/A	N/A	N/A	N/A	N/A	N/A
	Tempered	10000	10000	10000	N/A	N/A	N/A	N/A	N/A
60	Annealed	N/A	N/A	N/A	N/A	N/A	N/A	N/A	N/A
	Tempered	10000	10000	10000	N/A	N/A	N/A	N/A	N/A

SOUND TRANSMISSION

PRODUCT TYPE	EXTERIOR GLAZING	AIR SPACE	INTERIOR GLAZING	STC	OITC
Casement/Awning	ESCA	1/8" (3.1)	15/32" (11.5)	1/8" (3.1)	28 24
		1/8" (3.1)	13/32" (9.8)	3/16" (

WDMA STANDARDS AND PERFORMANCE GRADE (PG)

The Window and Door Manufacturers Association (WDMA), in conjunction with other organizations in the industry, has developed standards that make it easy to compare windows from different manufacturers, testing product performance regarding air and water infiltration, as well as physical loads on the exterior and interior (very important when you consider the pressure differentials that can occur in coastal areas, as well as forced entry resistance). Essential products are rated in accordance with the North American Fenestration Standard (AAMA/WDMA CSA 101/I.S.2/A440) and are certified in compliance with the WDMA Hallmark program.

Single Hung/Double Hung Equal Sash

CN	16	20	26	28	30	36	40
20	LC-PG50-H	LC-PG50-H	LC-PG50-H	LC-PG50-H	LC-PG50-H	LC-PG50-H	LC-PG50-H
26	LC-PG50-H	LC-PG50-H	LC-PG50-H	LC-PG50-H	LC-PG50-H	LC-PG50-H	LC-PG50-H
30	LC-PG50-H	LC-PG50-H	LC-PG50-H	LC-PG50-H	LC-PG50-H	LC-PG50-H	LC-PG50-H
36	LC-PG50-H	LC-PG50-H	LC-PG50-H	LC-PG50-H	LC-PG50-H	LC-PG50-H	LC-PG50-H
40	LC-PG50-H	LC-PG50-H	LC-PG50-H	LC-PG50-H	LC-PG50-H	LC-PG50-H	LC-PG50-H
46	LC-PG50-H	LC-PG50-H	LC-PG50-H	LC-PG50-H	LC-PG50-H	LC-PG40-H	LC-PG40-H
50	LC-PG50-H	LC-PG50-H	LC-PG50-H	LC-PG50-H	LC-PG50-H	LC-PG40-H	LC-PG40-H
56	LC-PG40-H	LC-PG40-H	LC-PG40-H	LC-PG40-H	LC-PG40-H	LC-PG40-H	LC-PG30-H
60	LC-PG40-H	LC-PG40-H	LC-PG40-H	LC-PG40-H	LC-PG40-H	LC-PG30-H	LC-PG30-H
66	LC-PG40-H	LC-PG40-H	LC-PG40-H	LC-PG40-H	LC-PG40-H	LC-PG30-H	LC-PG30-H

Single Hung Cottage/Reverse Cottage

CN	16	20	26	28	30	36	40
26	LC-PG50-H	LC-PG50-H	LC-PG50-H	LC-PG50-H	LC-PG50-H	LC-PG50-H	LC-PG50-H
30	LC-PG50-H	LC-PG50-H	LC-PG50-H	LC-PG50-H	LC-PG50-H	LC-PG50-H	LC-PG50-H
36	LC-PG50-H	LC-PG50-H	LC-PG50-H	LC-PG50-H	LC-PG50-H	LC-PG40-H	LC-PG40-H
40	LC-PG50-H	LC-PG50-H	LC-PG50-H	LC-PG50-H	LC-PG50-H	LC-PG40-H	LC-PG40-H
46	LC-PG40-H	LC-PG40-H	LC-PG40-H	LC-PG40-H	LC-PG40-H	LC-PG40-H	LC-PG30-H
50	LC-PG40-H	LC-PG40-H	LC-PG40-H	LC-PG40-H	LC-PG40-H	LC-PG30-H	LC-PG30-H
56	LC-PG40-H	LC-PG40-H	LC-PG40-H	LC-PG40-H	LC-PG40-H	LC-PG30-H	LC-PG30-H
60	LC-PG30-H	LC-PG30-H	LC-PG30-H	LC-PG30-H	LC-PG30-H	LC-PG25-H	LC-PG25-H
66	LC-PG25-H	LC-PG25-H	LC-PG25-H	LC-PG25-H	LC-PG25-H	LC-PG25-H	LC-PG25-H

Double Hung Cottage/Reverse Cottage

CN	16	20	26	28	30	36	40
26	LC-PG50-H	LC-PG50-H	LC-PG50-H	LC-PG50-H	LC-PG50-H	LC-PG50-H	LC-PG50-H
30	LC-PG50-H	LC-PG50-H	LC-PG50-H	LC-PG50-H	LC-PG50-H	LC-PG50-H	LC-PG50-H
36	LC-PG50-H	LC-PG50-H	LC-PG50-H	LC-PG50-H	LC-PG50-H	LC-PG40-H	LC-PG40-H
40	LC-PG50-H	LC-PG50-H	LC-PG50-H	LC-PG50-H	LC-PG50-H	LC-PG40-H	LC-PG40-H
46	LC-PG40-H	LC-PG40-H	LC-PG40-H	LC-PG40-H	LC-PG40-H	LC-PG40-H	LC-PG30-H
50	LC-PG40-H	LC-PG40-H	LC-PG40-H	LC-PG40-H	LC-PG40-H	LC-PG30-H	LC-PG30-H
56	LC-PG40-H	LC-PG40-H	LC-PG40-H	LC-PG40-H	LC-PG40-H	LC-PG30-H	LC-PG30-H

Glider

CN	26	30	36	40	46	50	60
16	LC-PG40-HS	LC-PG40-HS	LC-PG40-HS	LC-PG40-HS	LC-PG40-HS	LC-PG40-HS	LC-PG40-HS
20	LC-PG40-HS	LC-PG40-HS	LC-PG40-HS	LC-PG40-HS	LC-PG40-HS	LC-PG40-HS	LC-PG40-HS
26	LC-PG40-HS	LC-PG40-HS	LC-PG40-HS	LC-PG40-HS	LC-PG40-HS	LC-PG40-HS	LC-PG40-HS
30	LC-PG40-HS	LC-PG40-HS	LC-PG40-HS	LC-PG40-HS	LC-PG40-HS	LC-PG40-HS	LC-PG40-HS
36	LC-PG40-HS	LC-PG40-HS	LC-PG40-HS	LC-PG40-HS	LC-PG40-HS	LC-PG40-HS	LC-PG40-HS
40	LC-PG40-HS	LC-PG40-HS	LC-PG40-HS	LC-PG40-HS	LC-PG40-HS	LC-PG30-HS	LC-PG30-HS
46	LC-PG40-HS	LC-PG40-HS	LC-PG40-HS	LC-PG40-HS	LC-PG40-HS	LC-PG30-HS	LC-PG30-HS
50	LC-PG40-HS	LC-PG40-HS	LC-PG40-HS	LC-PG40-HS	LC-PG40-HS	LC-PG30-HS	LC-PG30-HS

Glider - Triple Sash

CN	60	70	80
16	LC-PG25-HS	LC-PG25-HS	LC-PG25-HS
20	LC-PG25-HS	LC-PG25-HS	LC-PG25-HS
26	LC-PG25-HS	LC-PG25-HS	LC-PG25-HS
30	LC-PG25-HS	LC-PG25-HS	LC-PG25-HS
36	LC-PG25-HS	LC-PG25-HS	LC-PG25-HS
40	LC-PG25-HS	LC-PG25-HS	LC-PG25-HS
46	LC-PG25-HS	LC-PG25-HS	LC-PG25-HS
50	LC-PG25-HS	LC-PG25-HS	LC-PG25-HS

Casement

CN	16	20	26	30
20	LC-PG40-C	LC-PG40-C	LC-PG40-C	LC-PG40-C
26	LC-PG40-C	LC-PG40-C	LC-PG40-C	LC-PG40-C
30	LC-PG40-C	LC-PG40-C	LC-PG40-C	LC-PG40-C
36	LC-PG40-C	LC-PG40-C	LC-PG40-C	LC-PG40-C
40	LC-PG40-C	LC-PG40-C	LC-PG40-C	LC-PG40-C
46	LC-PG40-C	LC-PG40-C	LC-PG40-C	LC-PG40-C
50	LC-PG40-C	LC-PG40-C	LC-PG40-C	LC-PG40-C
56	LC-PG40-C	LC-PG40-C	LC-PG40-C	LC-PG40-C
60	LC-PG40-C	LC-PG40-C	LC-PG40-C	LC-PG40-C
66	R-PG40-C	R-PG40-C	LC-PG40-C	LC-PG40-C
70	R-PG40-C	R-PG40-C	LC-PG40-C	LC-PG40-C

Sliding Patio Door

CN	50	510	60	80	90
68	LC-PG30-SD	LC-PG30-SD	LC-PG30-SD	LC-PG30-SD	LC-PG30-SD
610	LC-PG30-SD	Not Available	LC-PG30-SD	LC-PG30-SD	LC-PG30-SD
80	LC-PG30-SD	Not Available	LC-PG30-SD	LC-PG25-SD	LC-PG30-SD

Product Type	WDMA Certification
Awning	LC-PG40-AP
Direct Glaze Round Top	CW-PG50-FW
Direct Glaze	LC-PG50-FW
Double Hung Picture/Transom	LC-PG50-FW
Casement Picture/Transom	LC-PG40-FW

Mullion PG Rating may be determined by the lowest PG rating of the overall assembly. The Standard Mull has been certified to a PG25. The MRF Mull has been certified to a PG40.





Since 1912, Marvin has been a family-owned and -led company, with a legacy of innovation and commitment to the highest quality. We understand the unique opportunity windows and doors have to improve our spaces and how we feel in them. That's why we never stop pushing what's possible and inventing new solutions to channel fresh air, enhance light quality, and connect with the world around us.

MARVIN.COM

©2025 Marvin Lumber and Cedar Co., LLC. All rights reserved.
®Registered trademark of Marvin Lumber and Cedar Co., LLC.
ENERGY STAR® and the ENERGY STAR certification mark are registered US marks.

Cover image: Essential awning and picture windows Ultimate corner window

Part #19981903. January 2025.

Colors shown in printed materials are simulations and may not precisely duplicate product or finish colors. Contact your local Marvin dealer to view actual product and finish color samples.