

Elevate Casement/Awning Mullion Kit Instructions



BEFORE YOU BEGIN

IMPORTANT

Read these instructions thoroughly before beginning to assemble any multiple Marvin units. Failure to assemble as recommended will void any warranty, written or implied. Refer to specific product installation instructions for proper installation methods.

NOTE: When specifying or considering the structural load requirements for windows and doors, it is important to consider the method of fastening the unit(s) together in addition to the method of fastening multiple assemblies into an opening. The methods contained herein may not be appropriate for all performance requirements. Selection of the appropriate fastening method(s) is the sole responsibility of the installer, contractor, structural engineer, architect, building owner and/or installer.

Multiple assemblies can be ordered factory mullied up to 7 units wide by 1 unit high, or 4 units wide by 5 units high as long as the following limitations are not exceeded:

Maximum RO Height: 94 3/4" (2407) not to exceed 85" (2159) in width.

Maximum RO Width: 113" (2870) not to exceed 71 5/8" (1819) in height.

Assemblies exceeding these limitations must be field mullied and must be assembled using a structural mullion kit designed specifically for Marvin multiple assemblies. Contact your Integrity dealer for additional information.

The construction adhesive called for in the Round Top over Casement instructions should meet AFG-01 specifications, as established by the American Plywood Association.



WARNING

Practice safety! Wear safety glasses or goggles and appropriate hearing protection when assembling multiple Marvin window and door products.

Standard Mullion Kit

Parts Shipped With Standard Mullion Kit Casement/Awning

Illustrations (not to scale)	Description and Color	Part/Profile Number
	2-Mull filler blocks 14" (356)	W6172 33732900
	Interior mull trim*	W1243
	2-Wood mullion tie 12" (305)	W7004 33732920
	Mull sealant foam tape - 1 sided adhesive 96" (2438)	11869508
	Aluminum mulling pin*	A330
	Mullion insulation 96" (2438)	10501115
	2-Nailing fin connector*	10500213

* Length/color will vary depending on particular mull kit ordered.

You Will Need to Supply

Safety glasses	Hearing protection
Phillips screwdriver	Hammer
Power drill	3/16" drill bit
Clamps	Hacksaw
Silicone sealant w/gun	
1/2" crown x 1/2" leg 16 gauge staples w/gun	
3/16" crown x 1" leg 18 gauge staples w/gun	

Mulling Procedure - Standard

1. Lay frames on a flat surface in the desired mulling configuration (interior facing up). Remove nailing fin and/or drip cap from head jamb, sill, and side jambs that will be mulled together. Apply mull sealing tape the full length of the head jamb or jambs ensuring that it is located 1/4" (6) from the exterior edge of the Ultrex® as shown in figure 1.

NOTE: When assembling units vertically it will be necessary to remove standing block from underside of sill (upper unit only).

IMPORTANT

Units should be flush and square with each other.

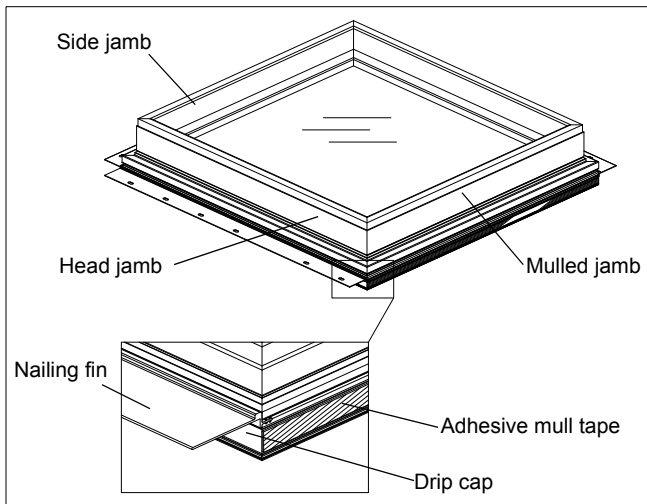

Figure 1

NOTE: If mulling a polygon to a casement unit drill out the outer edges of the nailing fin/drip cap kerf of the polygon unit on one end with a 3/16" (5) drill bit, clean filings out of kerf. This will ensure easy installation of the mulling pin.

2. Slide aluminum mulling pin into nailing fin/drip cap kerf. The mull pin ends must be recessed 1/4" (6) to allow sealant application later. See figure 2.

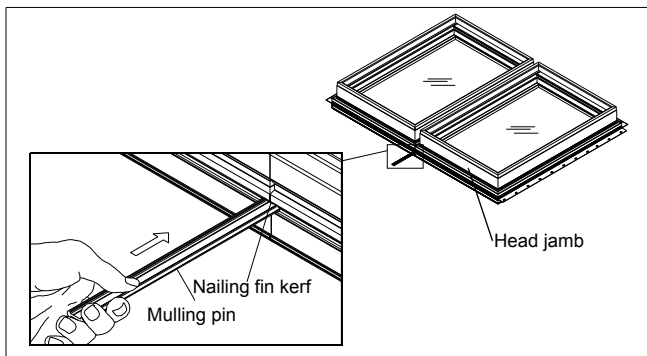

Figure 2

3. Insert mullion insulation between side jambs or head jamb and sill depending on your configuration. Insert mullion filler blocks at each end of mull cavity and at center in units with jambs 55" (1397) or longer. Attach blocks using 1/2" x 1/2" 16 gauge staples spaced every 4" (102). See figure 3. Attach mullion tie blocks at junction points with at least four 3/16" x 1" 18 gauge staples on each side of mullion as shown in figure 3.

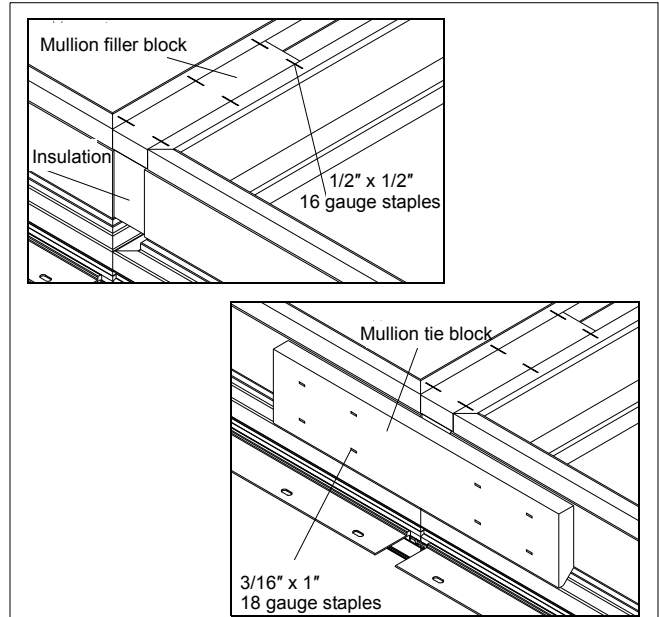

Figure 3

4. Apply silicone sealant at the mullion from the frame exterior edge to the drip cap/nailing fin kerf and across the kerf over the mulling pin as shown in figure 4. Apply nailing fin connectors at the head jamb and sill or jambs by removing the paper backing from the connector and pressing into place. See figure 4. Follow installation instructions for installing unit into rough or masonry opening. Interior mull trim should be applied after unit is completely installed and interior trim is applied.

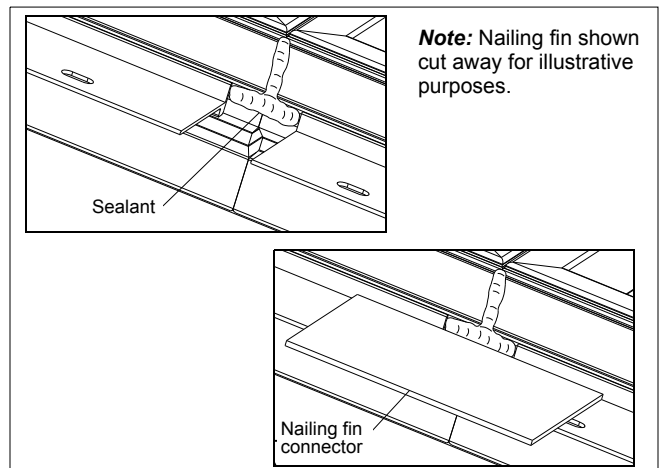
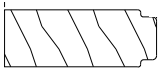

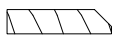
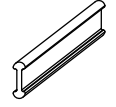
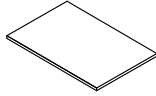
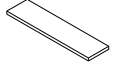

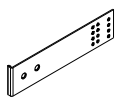

Figure 4

Note: Nailing fin shown cut away for illustrative purposes.

Structural Mullion Kit

Parts Shipped With Standard Mullion Kit Casement/Awning		
Illustrations (not to scale)	Description and Color	Part/Profile Number
	1-Mull reinforcement member	W7008
	Interior mull trim*	W1243
	2-Wood mullion tie 12" (305)	W7004 33732920
	Aluminum mulling pin*	A330
	2-Nailing fin connector*	10500213
	1-Roll mull sealant foam tape-one side adhesive 96" (2438)	11869508
	8-#8 x 1 3/4" screws	11881122
	8-#7 x 5/8" Phillips flat head screws	11800758
	4-Structural brackets 6" (152) 10" (254)	11860014 11860009

* Length/color will vary depending on particular mull kit ordered.

You Will Need to Supply

Safety glasses	Hearing protection
Phillips screwdriver	Hammer
Power drill	3/16" drill bit
Hacksaw	Silicone sealant w/gun
1/2" crown x 1/2" leg 16 gauge staples w/gun	
3/16" crown x 1" leg 18 gauge staples w/gun	

Mulling Procedures - Structural

NOTE: When using the mull reinforcement member provided with the Elevate Structural Mullion Kit the rough or masonry opening width and/or height does not need to be adjusted for the reinforcement. The reinforcement is placed into a pocket which is normally filled with insulation. When assembling in-sash units vertically using the Elevate mull reinforcement it is necessary to remove standing block from underside of sill (upper unit only).

1. Lay frames on a flat surface in the desired mulling configuration (interior facing up). Remove nailing fin and/or drip cap from head jamb, sill, and side jambs that will be mulled together. Apply mull sealing tape to the full length of the head jamb, jamb or sill ensuring that it is located 1/4" (6) from the exterior edge of the Ultrex frame as shown in figure 5.

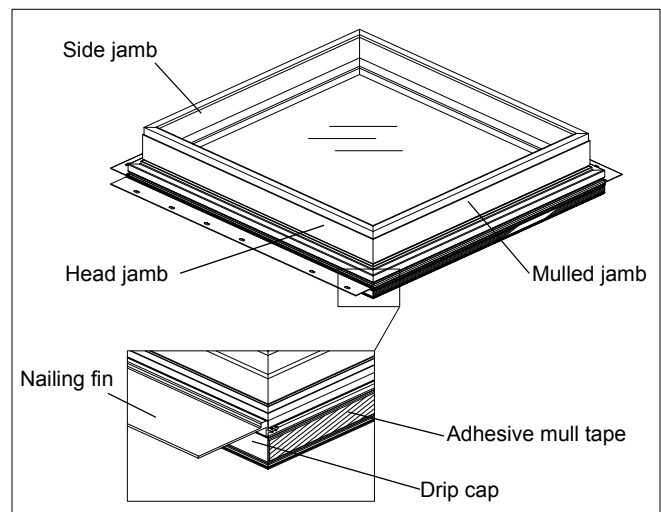

Figure 5

2. Attach mullion reinforcement member (W7008) vertically to side jambs or horizontally to head jambs (depending on mulling configuration) with #8 x 1 3/4" screws spaced every 12" (305) along the length of the reinforcement. See figure 6.

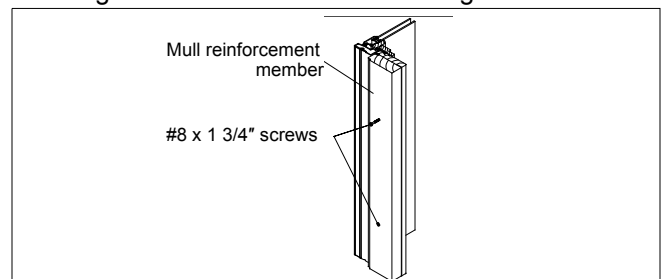

Figure 6

NOTE: Mull reinforcement member should be flush with side jambs (vertical reinforcement) or with head jambs and sills (horizontal reinforcement).

IMPORTANT

Units should be flush and square with each other.

NOTE: If mulling a direct glaze polygon to a casement, drill out the outer edges of the nailing fin/drip cap kerf of the polygon on one end with a 3/16" drill bit. Clean filings out of kerf. This will ensure easy installation of the mulling pin.

3. With frames in the desired mulling configuration (interior facing up) clamp units together on interior near each end of the mullion (use scrap blocks to protect interior wood frame members). Slide aluminum mulling pin into nailing fin/drip cap kerf as shown in figure 7. Make sure mulling pin is recessed 1/4" to allow for sealant placement later.

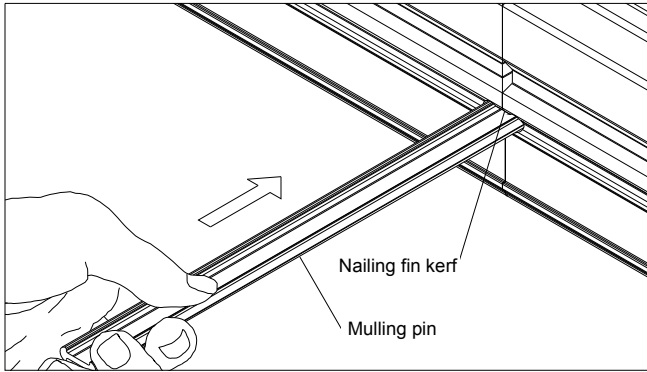

Figure 7

4. Fasten interior wood frame members with 1/2"x1/2" 16 gauge staples spaced every 4" (102). See figure .

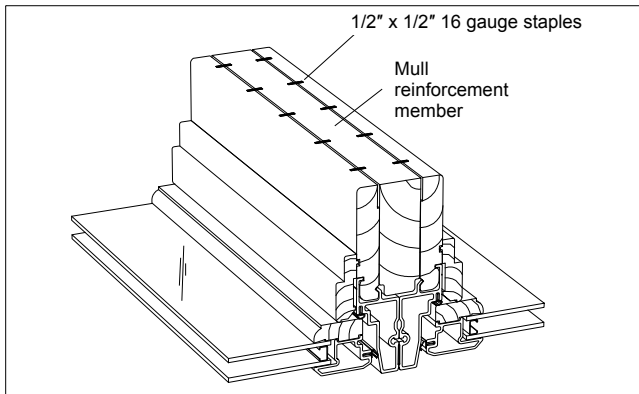

Figure 8

5. Attach mullion tie blocks at junction points with at least four 3/16" x 1" 18 gauge staples on each side of mullion as shown in figure 9.

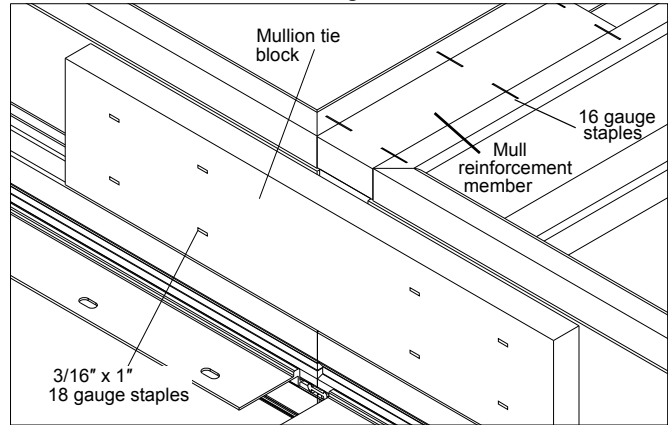

Figure 9

6. Attach structural brackets on each side of the mullion using two #7 x 5/8" screws provided. Structural brackets should be installed within 6" of mull as shown in figure 10.

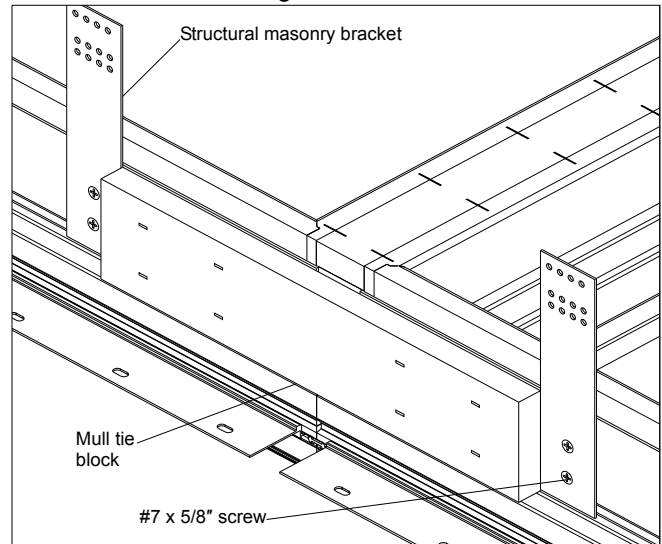

Figure 10

7. Apply silicone sealant at the mullion from the frame exterior edge to the drip cap/nauling fin kerf and across the kerf over the mulling pin as shown in figure 11. Apply nauling fin connectors at the head jamb and sill or jambs by removing the paper backing from the connector and pressing into place. See figure 11. If applicable jamb extension can now be applied. Follow installation instructions for installing unit into rough or masonry opening. Interior mull trim should be applied after unit is completely installed and interior trim is applied.

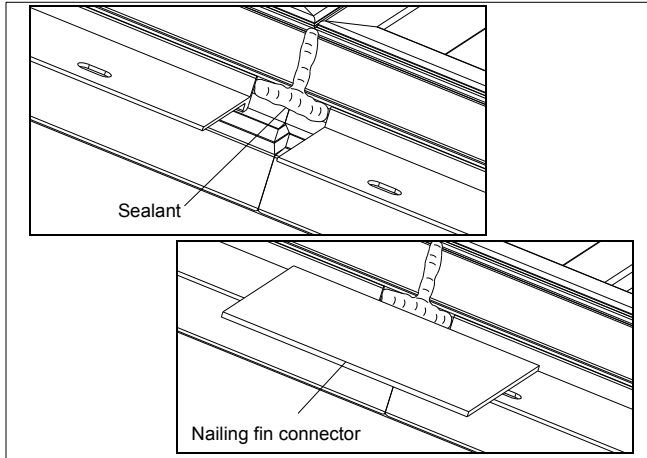

Figure 11

2 Wide x 2 High Configuration

Parts Shipped With Mullion Kit: 2 Wide x 2 High Mulling Configurations Casement/Awning/Polygon

Illustrations (not to scale)	Description and Color	Part/Profile Number
	Aluminum mulling pin*	A330
	1-Mullion reinforcement	W7008
	2-Mullion filler blocks 14" (356)	W6172 33732900
	2-Wood mullion tie 12" (305)	W7004 33732920
	Interior mullion trim*	W1243
	1-Roll mull sealant foam tape- one sided adhesive 96" (2438)	11869508
	4-Elevate structural brackets <i>Note: 10" not supplied with kit used on 6 9/16" or 6 13/16" jambs, must be ordered separately.</i>	6" (152)- 11860014 10" (254)- 11860009
	2-Nailing fin connector*	10500213
	Mullion insulation 96" (2438)	10501115
	8-#7 x 5/8" screws	11800758
	8-#8 x 1 3/4" screws	11881122

* Length/color will vary depending on particular mull kit ordered.

You Will Need to Supply

Safety glasses	Hearing protection
Phillips screwdriver	Hammer
Power drill	3/16" (5) drill bit
Hacksaw	Silicone sealant w/gun
1/2" crown x 1" leg 16 gauge staples w/gun	
3/16" crown x 1" leg 18 gauge staples w/gun	

IMPORTANT

2 wide 2 high configurations require the use of a structural mull reinforcement member (W7008) and structural mullion brackets. Mull reinforcement member should be added to the shortest span. Reinforcement member is installed horizontally in the procedures described below. Mull reinforcement member can be installed vertically provided that it is the shortest span. Left and right halves of unit would then be mullled prior to installing the vertical mulling pin and reinforcement member.

NOTE: Illustrations for mulling the upper units of a 2 wide x 2 high assembly show direct glaze polygons. Procedures are the same for in-sash transoms or awnings.

Mulling Procedures - Upper 2 Wide Assembly

1. Lay the two direct glaze polygon, in sash transom, or awnings that will be mullled above the two casement units in the desired mulling configuration (interior facing up). Remove nailing fin from sill and side jambs that will be mullled together. If mulling direct glaze polygons above casement units drill out the outer edges of the sill nailing fin/drip cap kerfs on each corner and head jamb at mullion with a 3/16" drill bit. Clean filings out of kerf. This will ensure easy installation of the mulling pin. Apply mull sealing tape the full length of the jamb ensuring that it is located 1/4" (6) from the exterior edge of the Ultrex frame as shown in figure 19.

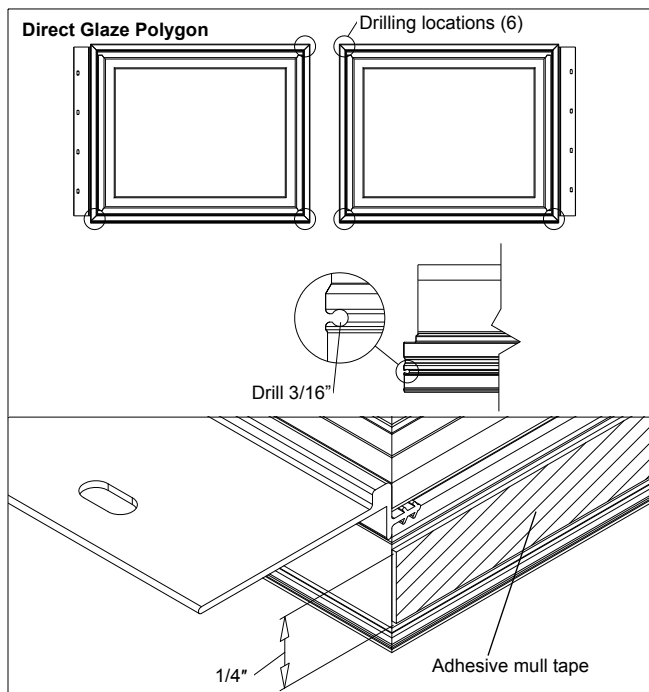

Figure 19

2. Slide aluminum mulling pin into nailing fin drip cap kerf. Make sure mulling pin is recessed at least 1/4" on each end to allow for sealant placement and horizontal mulling pin application later. See figure 20.

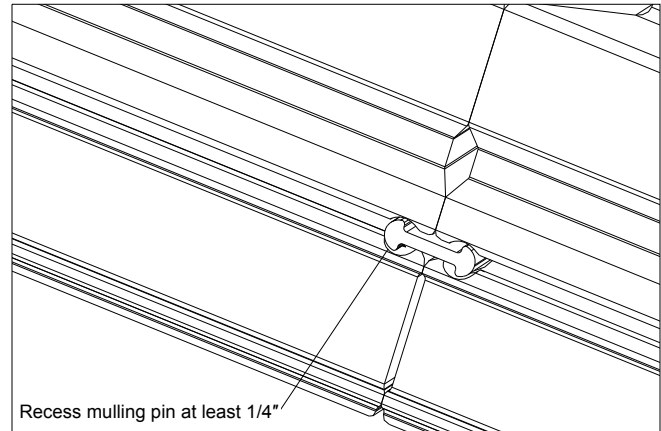

Figure 20

3. Insert mullion insulation between side jambs. Insert mullion filler blocks at each end of mull cavity. Attach blocks using 1/2" x 1/2" 16 gauge staples spaced every 4" (102). See figure 21.

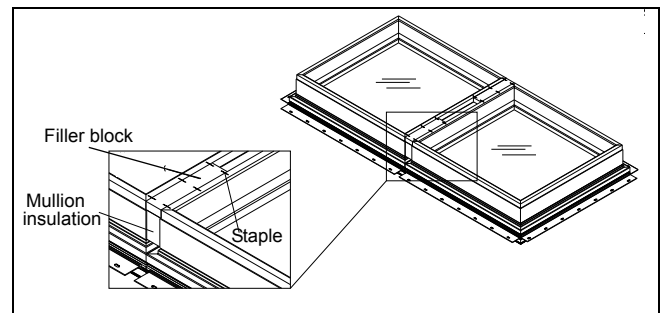

Figure 21

4. Attach mullion tie blocks at head jamb mullion with at least four 3/16" x 1" 18 gauge staples on each side as shown in figure 22. Carefully set the upper units aside.

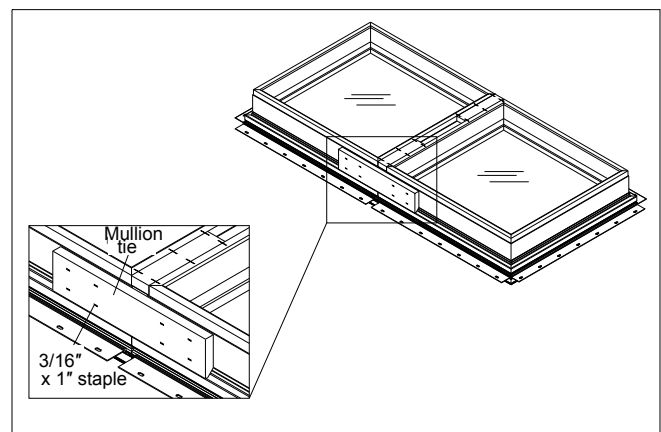

Figure 22

Mulling Procedures - Lower 2 Wide Assembly

NOTE: Illustrations for mulling the lower units of a 2 wide x 2 high assembly show in-sash stationary units. Procedures are the same for operating Casements or direct glaze polygons.

1. Lay the lower casement frames on a flat surface in the desired mulling configuration (interior facing up). Remove nailing fin and drip cap from head jambs and side jambs that will be mulled together. Apply mull sealing tape the full length of the jamb ensuring that it is located 1/4" (6) from the exterior edge of the Ultrex frame as shown in figure 23.

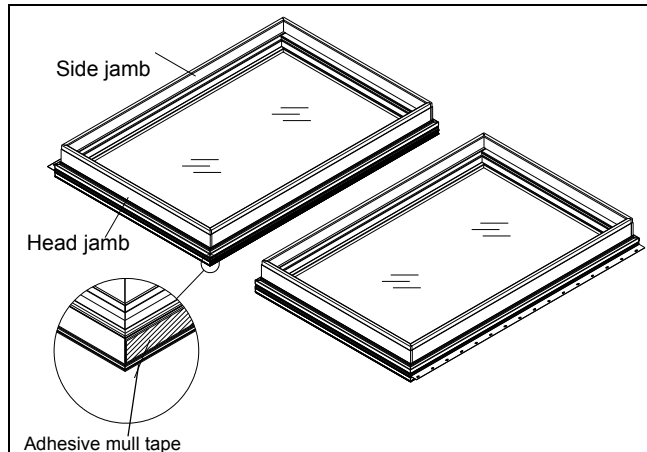

Figure 23

NOTE: If mulling direct glaze polygons, drill out the outer edges of the head jamb nailing fin/drip cap kerfs at all corners.

2. Slide aluminum mulling pin into nailing fin/drip cap kerf. Make sure mulling pin is recessed at least 1/4" on each end to allow for sealant placement and horizontal mulling pin application later. See figure 24.

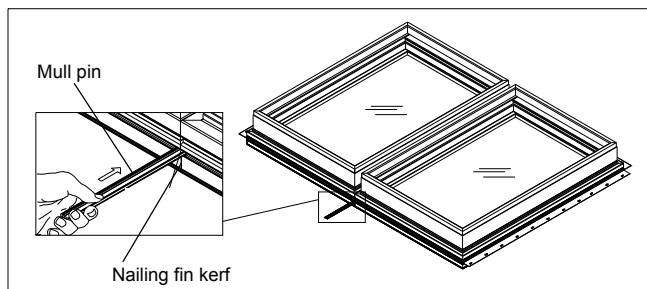

Figure 24

3. Insert mullion insulation between side jambs or head jamb and sill depending on your configuration. Insert mullion filler blocks at each end of mull cavity and at center in units with jambs 55" (1397) or longer. Attach blocks using 1/2" x 1/2" 16 gauge staples spaced every 4" (102). Attach mullion tie blocks at sill mullion with at least four 3/16" x 1" 18 gauge staples on each side as shown in figure 25.

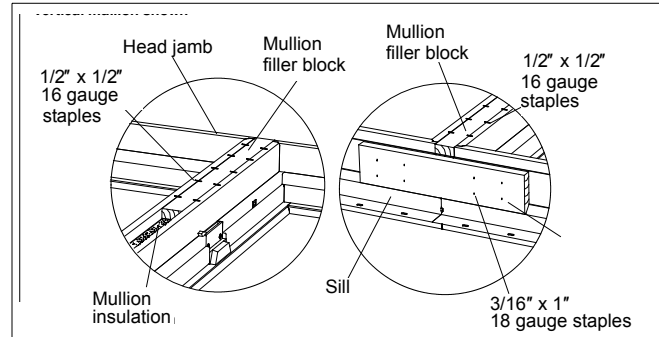

Figure 25

Mulling Procedures - 2 Wide 2 High Unit Assembly

1. Apply mull sealing tape the full length of the head jamb of the lower 2 wide casement assembly ensuring that it is located 1/4" (6) from the exterior edge of the Ultrex frame similar to steps 1 and 5.
2. Attach mullion reinforcement member (W7008) to head jambs of lower unit with #8 x 1 3/4" screws spaced every 12" (305) as shown in illustration 27. Set upper and lower mulled units in the desired configuration (interior facing up). Clamp units together on interior near each end of the mullion (use scrap blocks to protect interior wood frame members). Slide horizontal aluminum mulling pin into nailing fin kerf. Make sure mulling pin is recessed at least 1/4" on each end to allow for sealant application later. Fasten interior wood frame members with 1/2" x 1/2" 16 gauge staples spaced every 4" (102). See figure 26.

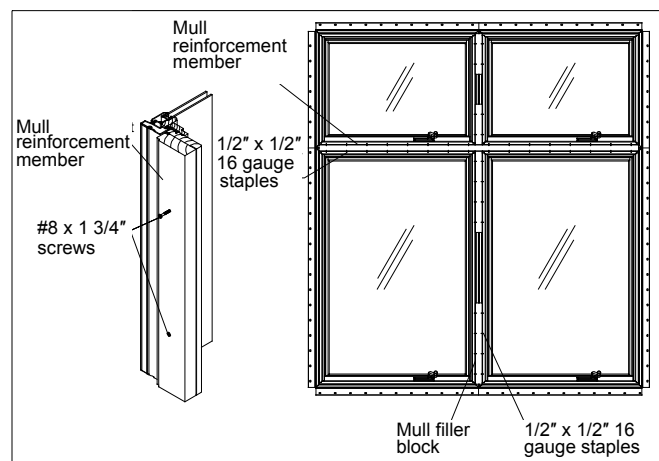

Figure 26

3. Center and attach mullion tie blocks at mullion with at least four 3/16" x 1" 18 gauge staples on each side of mullion as shown in figure 27. Attach structural masonry brackets on each side of mullion using two #7 x 5/8" screws. Structural brackets should be installed within 6" of mullion junction as shown in figure 27.

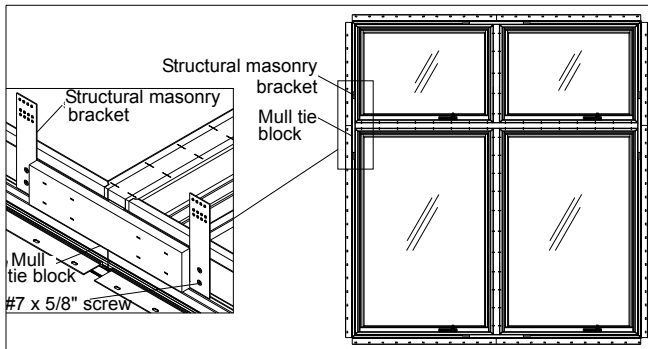

Figure 27

4. Apply silicone sealant at the mullions from the frame exterior edge to the drip cap/nailling fin kerf and across the kerf over the mulling pin as shown in figure 28. Apply nailing fin connector at the head jamb, sill, and jambs by removing the paper backing from the connector and pressing into place. See figure 28. If applicable, jamb extension can now be installed. Follow installation instructions for installing unit into rough or masonry opening. Interior mull trim should be applied after unit is completely installed and interior trim is applied.

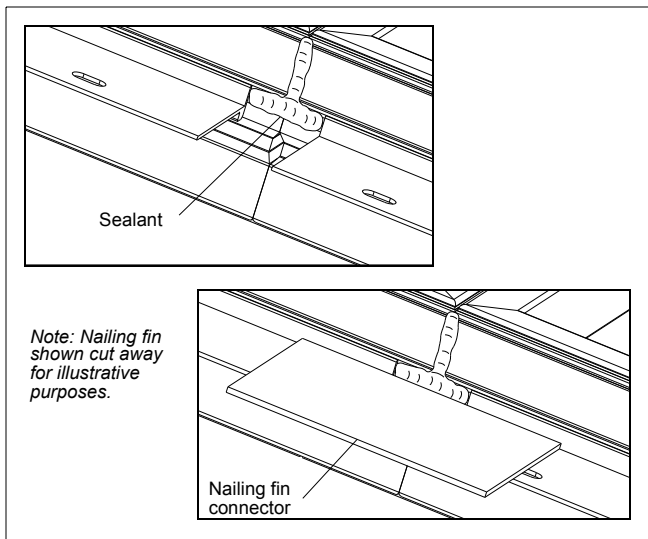

Figure 28

ELALDGR T Casement Mullion Kit Instructions

Standard Parts Shipped with ELALDGR T to Casement Mullion Kits

Illustrations (not to scale)	Description and Color	Part/Profile Number
	2-Mull splice blocks 12" (305) <i>NOTE: Not used on RT1 over Casement</i>	W7004 33732920
	4-Mull filler blocks 14" (356)	W6172 33732900
	2-Mull tin 2 1/2" x 16" (64 x 406)	02070460
	2- Foam nailing fin connectors	10500213
	1-Roll- Mull sealant foam tape- one sided adhesive 96" (2438)	11869508
	1- Aluminum mulling pin*	A330
	Mullion insulation- 96" (2438)	10500213
	1-Horizontal mull trim*	A330
	4- Structural brackets <i>Note: 10" bracket is not supplied, must be ordered separately.</i>	6"(152)- 11860014 10"(254)- 11860009
	8- #7 x 5/8" Phillips flat head wood screws	11800758

* Length/color will vary depending on particular mull kit ordered.

NOTE: Units may be shown without nailing fin in figures 29-35 for illustration purposes.

You Will Need to Supply

Safety glasses	Hearing protection
Wood saw	3/16" drill bit
Clamps	Silicone sealant w/gun
Hammer	
Power drill/driver w/Phillips head bit	
1/2" x 1/2" 16 gauge staples w/gun	

Mulling Procedures

1. Lay frames on a flat surface in the desired mulling configuration (interior facing up). Removing nailing fin/drip cap and any shipping blocks from mullion locations. Using a wood saw cut the ends of the jambs on the ELALDGRT so that it is flush with the sill. See figure 29.

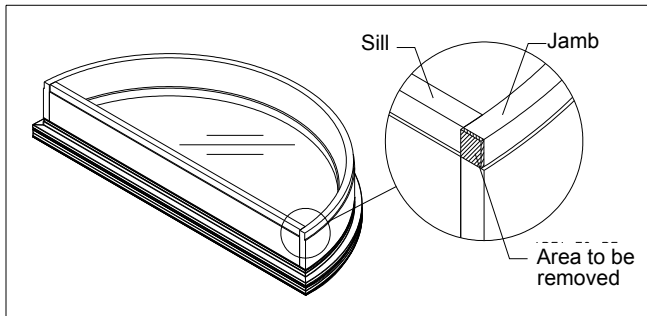

Figure 29

2. Apply mull sealing tape to the full length of the mullion on the casement unit jamb or head jamb, ensuring that it is located 1/4" (6) from the exterior edge of the Ultrex frame. See figure 3. Remove paper backing from mull tape.

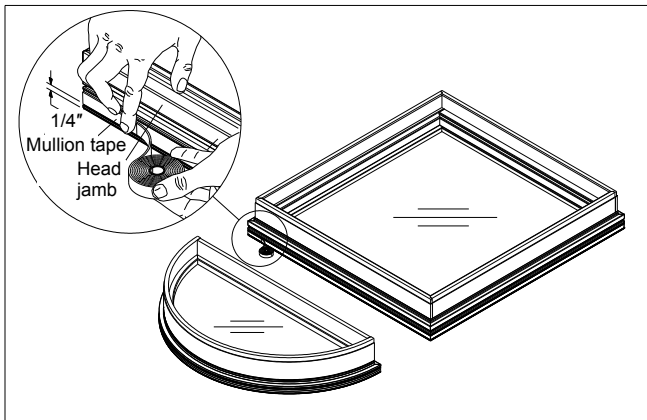

Figure 30

3. Drill out end of nailing fin/drip cap kerf on ELALDGRT units with a 3/16" drill bit. This will ease the installation of the mulling pin. Clean away any fibers or filings from the kerf area.

NOTE: If mulling a direct glaze polygon to an ELALDGRT, drill out the polygon nailing fin/drip cap kerf as well.

4. Place frames together and slide aluminum mulling pin into nailing fin/drip cap kerf. A hammer may aid in the application of the mull pin. The mull pin ends must be recessed 1/4" to allow sealant application later. See figure 31.

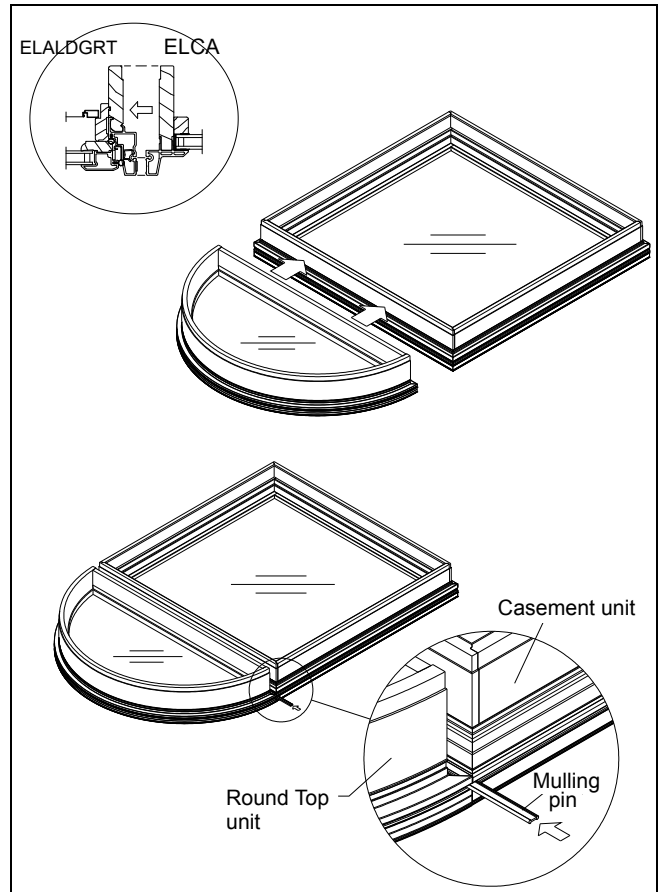

Figure 31

5. Insert mullion insulation between mullions. Insert mullion filler blocks (W6172) at each end and if necessary, center of mull cavity. Clamp the units together and attach blocks using 1/2" x 1/2" 16 gauge staples spaced every 4". See figure 32.

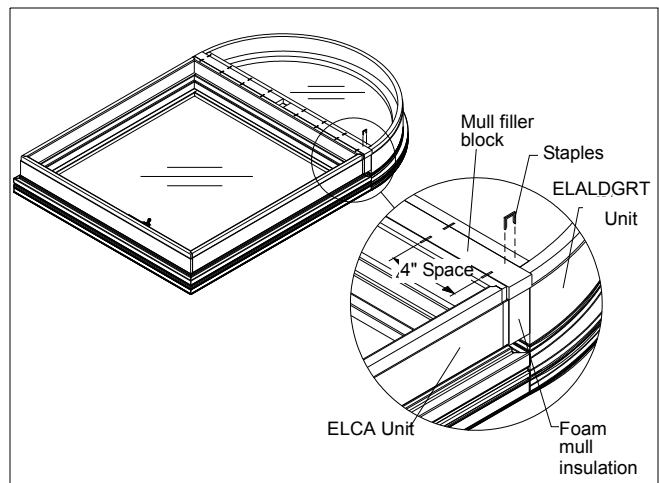

Figure 32

6. Center and attach mulling tin over mullion and fasten securely with 1/2" x 1/2" 16 gauge staples to wood members using the staggered pattern shown in figure 33. On vertical mulling configurations with uneven headers such as an RT2 or RT6, first crease the mullion tin in half to ease installation.

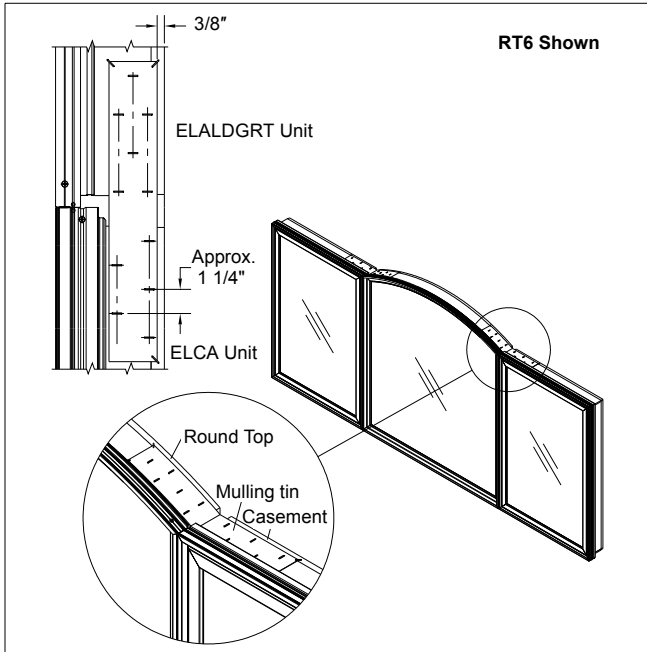

Figure 33

8. Apply silicone sealant at the mullion from the frame exterior edge to the drip cap/nauling fin kerf and across the kerf over the mulling pin. Remove paper backing from nauling fin connectors and press into place as shown in figure 35. Seal around the edge of the connectors as shown.

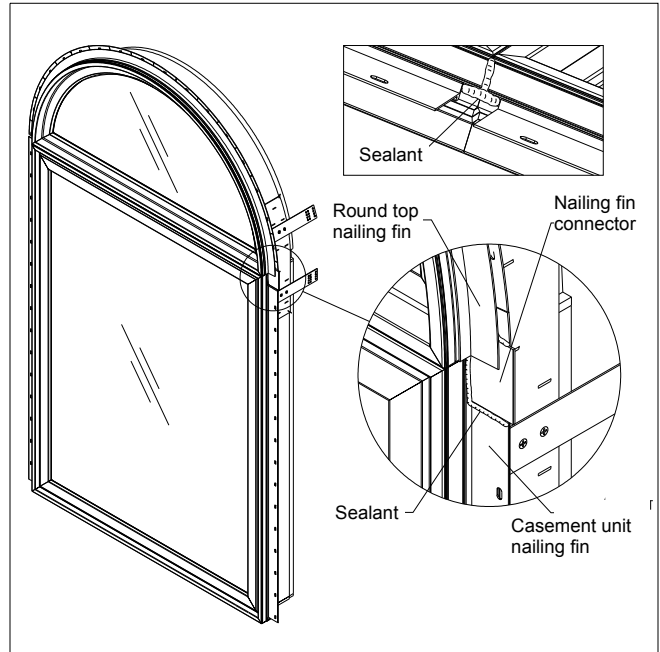

Figure 35

7. When mulling RT2 or RT6 over a casement unit, apply one structural masonry bracket approximately 4" (102) from each side of the mullion on both jambs. Attach each of the brackets with one of the #7 x 5/8" screws provided. See figure 34.

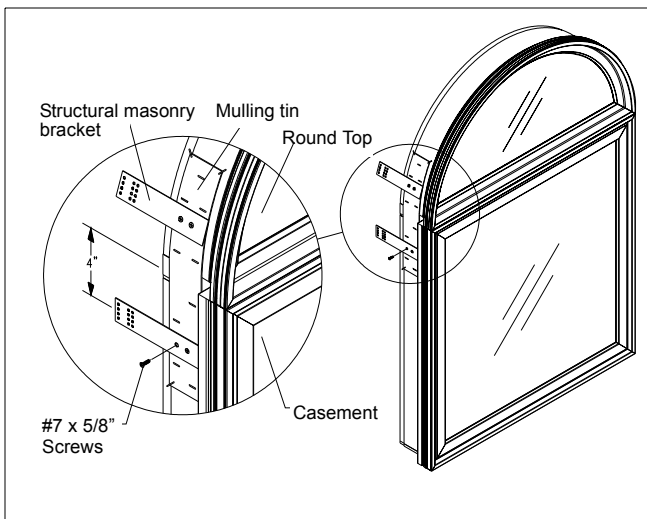

Figure 34

9. If applicable, jamb extension can now be installed. Follow installation instructions for installing unit into rough or masonry opening. Mull trim should be applied after the unit is completely installed and interior trim is applied.

NOTE: It is important that care be exercised when moving a mullied assembly from the mullion area to the rough opening.