

# Coastline Glider

## Installation Instruction

---

**ABSTRACT:** These instructions advise the window installer/carpenter/contractor on the recommended way to install Marvin Coastline windows where structural installation is necessary, including those rated for use in Impact Zone 4.

These instructions are applicable for the following products: Coastline Glider IZ4 - FL33619.1 and FL33619.2.

In addition to steps for installing your window, included within are: Rough opening (RO) preparation for recessed masonry applications; RO prep and sealing details for standard wood frame construction; detailed fastening methods and more.

The procedures within these instructions are consistent with those used in testing to achieve the advertised DP (Design Pressure) rating. Contact your local Marvin dealer if your construction scenario differs from those detailed within. Regional standard practices, environmental conditions and codes may vary and supersede the procedures contained within. The responsibility for compliance is yours: the installer, inspector, and owner(s). See the Technical Installation Specifications inside for more details.

---

### Table of Contents

Before You Begin .....	1
After Market Products .....	2
Installer and Builder Information .....	2
You will need to supply:.....	3
Rough Opening Preparation and Framing Requirements.....	3
Unit Preparation .....	5
Installing the Window .....	6
Typical Anchors .....	9
Continuous Air Barrier Systems-Preparing the Opening.....	10
Flashing the Installation .....	11
Technical Specifications .....	13

---

### Before You Begin



Always practice safety! Wear the appropriate eye, ear, and hand protection, especially when working with power tools.



This product can expose you to chemicals including titanium oxide, which is known to the state of California to cause cancer. For more information, go to [www.P65Warnings.ca.gov](http://www.P65Warnings.ca.gov).

## **WARNING!**

This product can expose you to chemicals including methanol, which is known to the state of California to cause birth defects or other reproductive harm. For more information, go to [www.P65Warnings.ca.gov](http://www.P65Warnings.ca.gov).

## **WARNING!**

Older homes may contain lead-based paint, which may be disturbed when replacing windows or performing renovations. Consult state or local authorities for safe handling, disposal, or abatement requirements. For more information, go to [www.epa.gov/lead](http://www.epa.gov/lead).

## **WARNING!**

**Do NOT lift or move without proper equipment.**  
**Read, understand, and follow all lift equipment manufacturers' instructions and safety information.**

## **CAUTION!**

Be aware that the use of rigid sill pans and other barriers will decrease the rough opening height clearance. Adjust opening dimensions accordingly.

---

### ***After Market Products***

Alterations to Marvin products including window films, insulating or reflective interior window treatments or additional glazing can cause excessive heat buildup and/or condensation. They may lead to premature failures not covered under warranty by Marvin Windows and Doors.

Before purchasing or applying any product that may affect the installation or performance of Marvin windows or doors, contact the manufacturer of after-market product/glazing that are not supplied by Marvin and request written product use, associated warranties and damage coverage. Provide this information and warranties to the end user and/or building owner for future reference.

---

### ***Installer and Builder Information***

- Always provide a copy of these instructions for the current homeowner.
- Plan sizing of rough opening and clearance from exterior finishing systems to allow for normal materials shrinkage or shifting (e.g. wood structure with brick veneer; allow adequate clearance at the sill). Failure to do so can void the Marvin warranty coverage.
- It is the responsibility of the builder, installer, and subcontractors to protect the interior and exterior of windows or doors from contact with harsh chemical washes, construction material contamination and moisture. Damage to glazing, hardware, weather strip and cladding can occur. Protect with painters tape and/or protective sheathing as required. Follow all guidelines regarding material use, preparation, personal safety and disposal.
- Contact your Marvin supplier if you have any questions regarding product and materials used in manufacturing or questions on replacement parts.
- Please refer to the PDF version of this instruction for further information regarding best practices, installer and builder information, code, and other legal requirements. The PDF version is the official document of record.

---

## You will need to supply:

- Square
- Shims
- Tape measure
- Sill pan flashing
- Level
- Safety Glasses
- Backing material (foam backing rod)
- Insulation
- Appropriate fasteners ([refer to Typical Anchors on page 9](#))
- Glass vacuum suction cups
- Perimeter sealant<sup>1</sup>
- Low expansion foam insulation<sup>2</sup>
- Construction adhesive<sup>3</sup>

---

1. Sealant must be minimum Grade NS Class 25 per ASTM C920 and compatible with building exterior and window surface.

2. Optional, use low expansion foam insulation only. Foam and foam application must comply with ASTM E2112, section 5.9.2.

3. APA rated AFG-01 spec

---

## Rough Opening Preparation and Framing Requirements

This section gives requirements for framing and rough opening clearances. Masonry or concrete openings may be lined with a treated wood product (1by wood buck). You must fasten the buck to the masonry opening in a fashion that will withstand conditions which would be encountered under the certified and advertised DP ratings for this window. The structural integrity of this installation is only as good as the bond between the wood buck and the masonry opening. For more details, contact your Marvin representative.

*NOTE: Wood bucks and buck fasteners by others, must be designed and installed adequately to transfer applied product loads to the building structure.*

1. Apply a barrier such as self-sealing adhesive flashing or CMU sealer (liquid-applied coating) to all four sides of the masonry opening prior to buck and window installation. Begin by waterproofing the masonry opening on the installation surface, as well as 6" outwards on the inside and outside of the wall itself following local code and manufacturer requirements. [See Figure 1.](#)

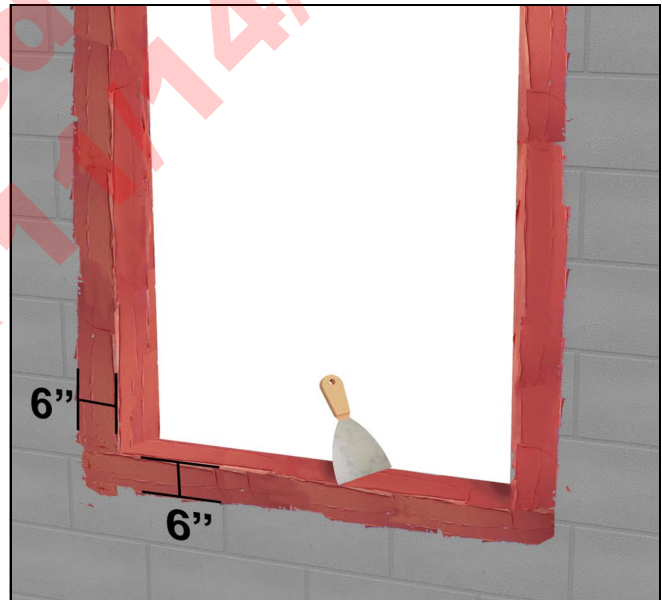

Figure 1

2. **Optional:** Line all sides (jamb, head jamb, and sill) with treated lumber. Apply lumber to the masonry opening with construction adhesive to ensure weather-resistant barrier. The buck material should be installed in such a manner that all gaps between the buck and structure are sealed. If using a self-sealing adhesive flashing or CMU sealer, waterproof over the buck material, ensuring overlap with the previous coating. [See Figure 2.](#)



Figure 2

3. If you will not be using rigid panning, you could instead apply a barrier such as self sealing adhesive flashing or CMU sealer (liquid-applied coating) to all four sides of the masonry opening, buck wood and return on the face of the exterior substrate prior to window installation. See Figure 3.



Figure 3

## ATTENTION

Be aware that use of rigid sill pans and other barriers will decrease the rough opening height clearance. Adjust opening dimensions accordingly.

## ! CAUTION!

If the previous conditions are not met, the installer must take corrective actions to alter the opening(s) before proceeding. It is also essential that the sheathing behind the wall be a solid surface to ensure that the unit can be secured firmly to the wall.

4. On installations with brick veneer (Masonry), verify there is at least 1/2" between bottom of window sill (or eventual placement of the window) and the top row of brick to avoid "brick bind". See Figure 4.



Figure 4

5. Masonry Openings (MO) for flanged windows should be 1" greater than outside frame (flange) measurement. The Rough Opening (RO), with or without a wood buck, should result in a 1/2" overall shim space, 1/4" per side. Size the Masonry Opening (MO) accordingly, based on the wood buck specifications. When framing a rough opening, ensure the sill plate is level and the opening is square, straight, and plumb. See Figure 5.

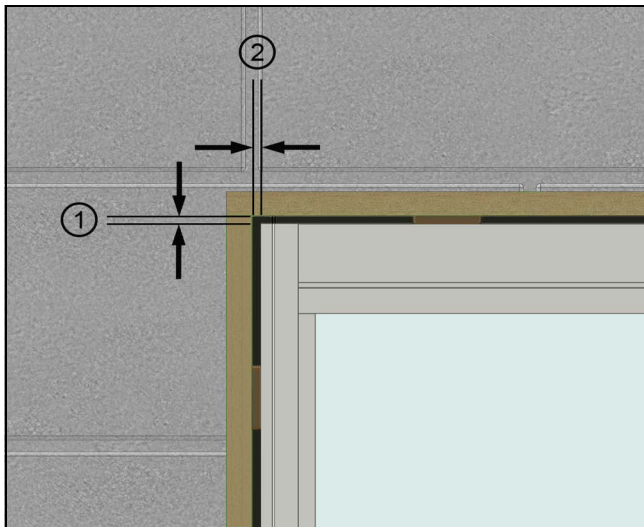

Figure 5

1	Interior Shim Space, 1/4"
2	Interior Shim Space, 1/4"

## Unit Preparation

1. Remove the protective packaging from the unit and dispose/recycle properly. Inspect unit for any hidden damage and report immediately to your Marvin representative. Provide the order number on the product label attached to the unit. See Figure 6.
2. Remove Operator Sash and Sill Track, set aside. See Figure 7.



Figure 6

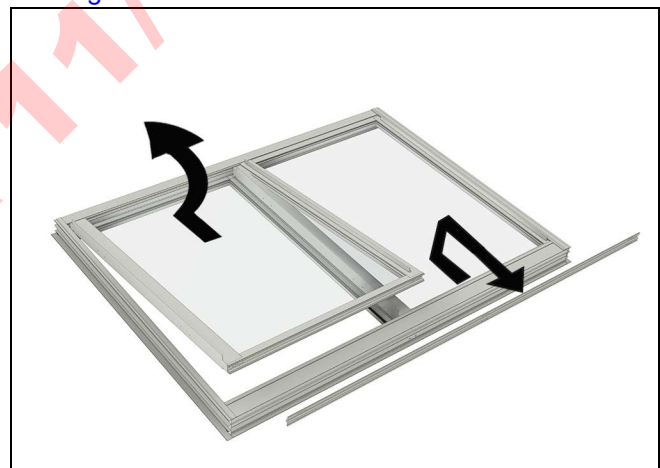

Figure 7

3. A window frame being installed with a sealing flange attached must be installed from the exterior. Apply a continuous bead of sealant to the back side of the flange on the interior surface. Alternatively, sealant may be applied to the framed opening at the point where the back side of the sealing flange will contact the perimeter seal. See Figure 8.

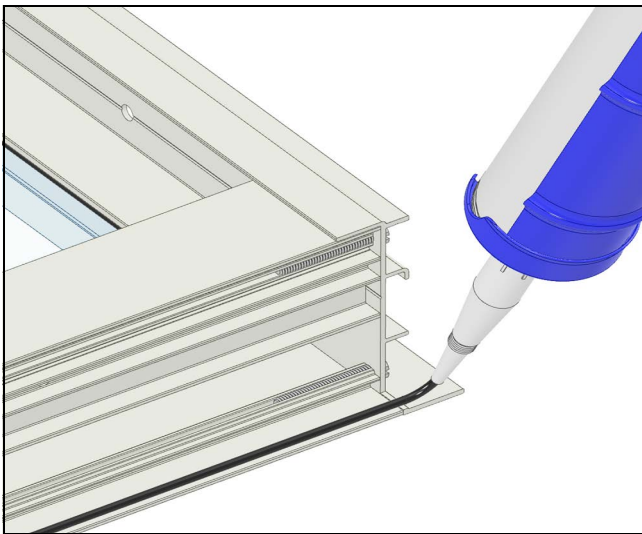

Figure 8

4. Add an additional bead of sealant following the flange jamb to sill miters and the head jamb to jamb

miters on the interior surface of the flange. See Figure 9.

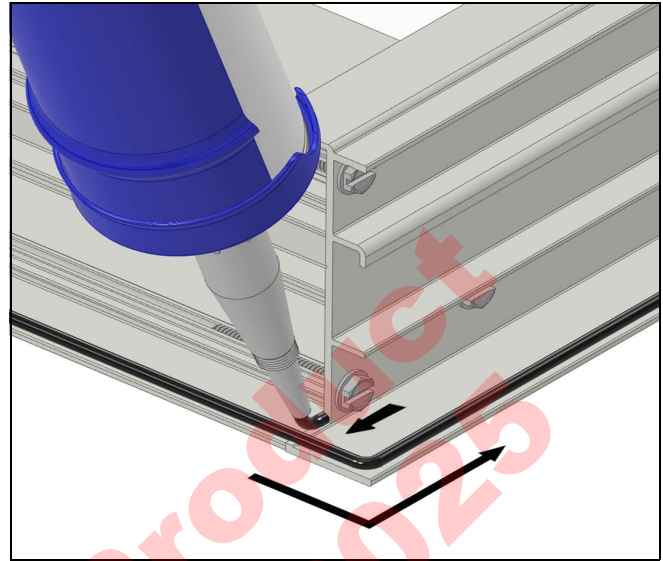

Figure 9

## Installing the Window

The following steps provide details for the structural fastening of the window to the opening. On applicable construction using a continuous air barrier system, prepare the opening before installing the window. Refer to the "Continuous Air Barrier Systems" section for details.

1. It is recommended to have at least two people, with one inside and one outside, to support the unit during installation.



### Seek Assistance

Some large windows and/or assemblies are very heavy. Avoid injury by getting help to lift and position the window into the rough opening.

## CAUTION!

Proper shimming is extremely important. Under-shimming or over-shimming will result in bowed jambs and/or head jamb. Both conditions can contribute to improper window operation.

2. Lift and place the unit into the opening, with the flange securely against the opening surface. Then add shims to each corner to initially pin the unit. See Figure 10.

*NOTE: For safety and to prevent unit damage, continue to maintain support on the unit until a few fasteners are pinned through the head jamb or jambs.*

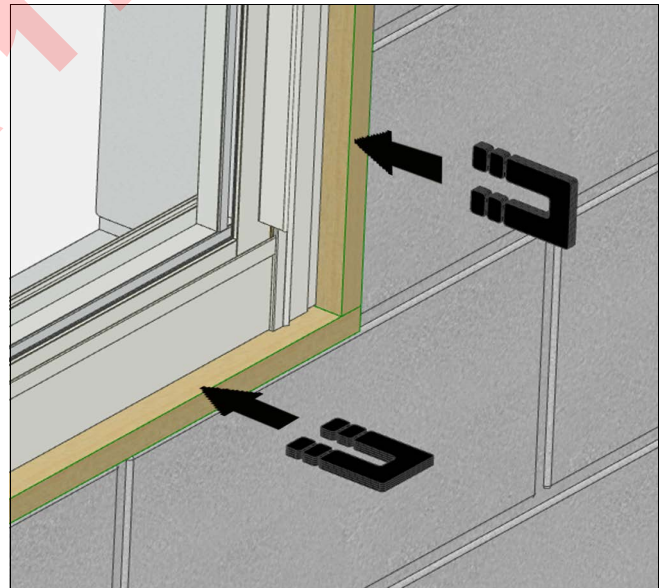

Figure 10

3. Install one fastener through the head jamb to affix the unit to the opening. Follow instructions in the section, "Typical Anchors on page 9". See Figure 11.

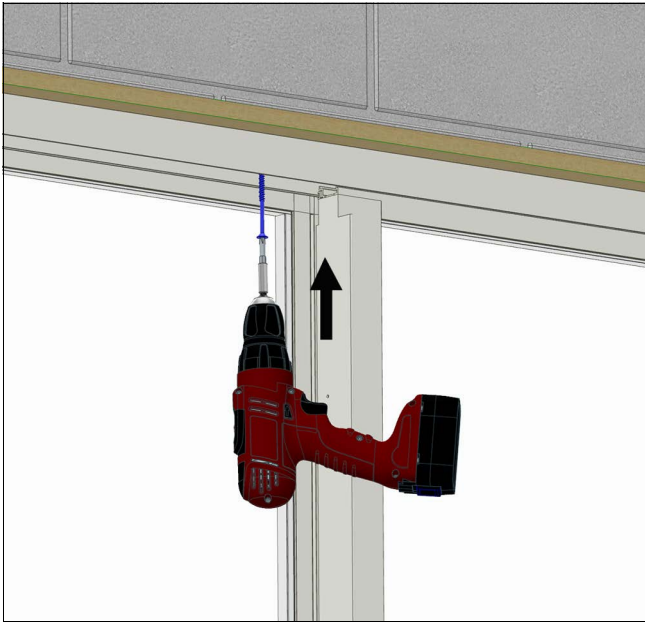

Figure 11

4. Center the window in the opening and ensure the unit is level at the sill. Then continue to add shims at each installation fastener anchor hole around the perimeter of the unit. See Figure 12.

*NOTE: The shims should fill the gap without being loose or deforming the frame. Be sure not to over-tighten the fasteners.*

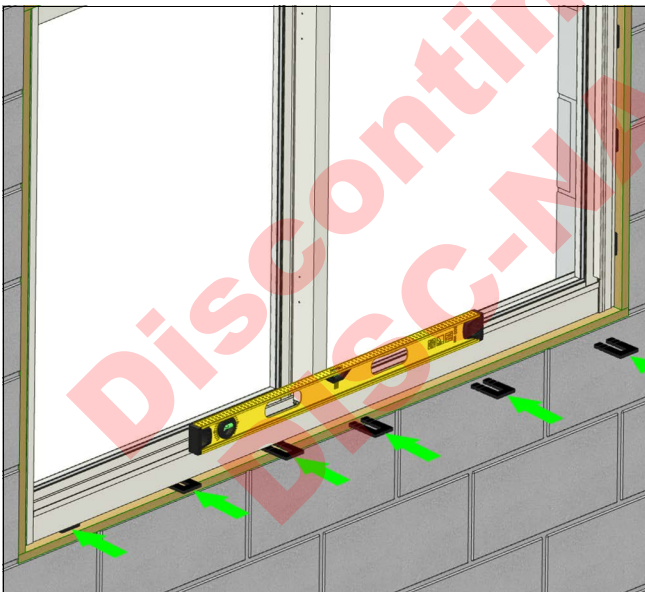

Figure 12

5. As needed, pre-drill the installation holes through the frame and into the installation opening (See Typical Anchors on page 9). See Figure 13.

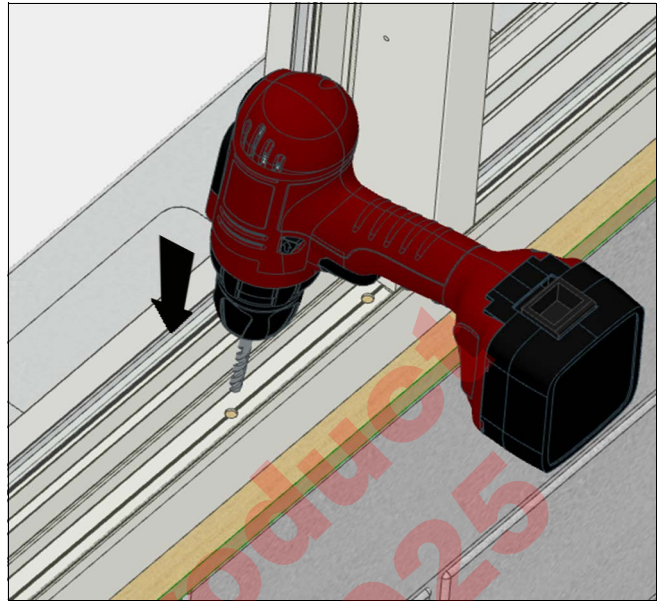

Figure 13

6. Inject sealant into and around the installation holes in the frame. See Figure 14.



Figure 14

7. Fasten the unit into the opening through all installation holes using appropriate fasteners (See Typical Anchors on page 9). See Figure 15.

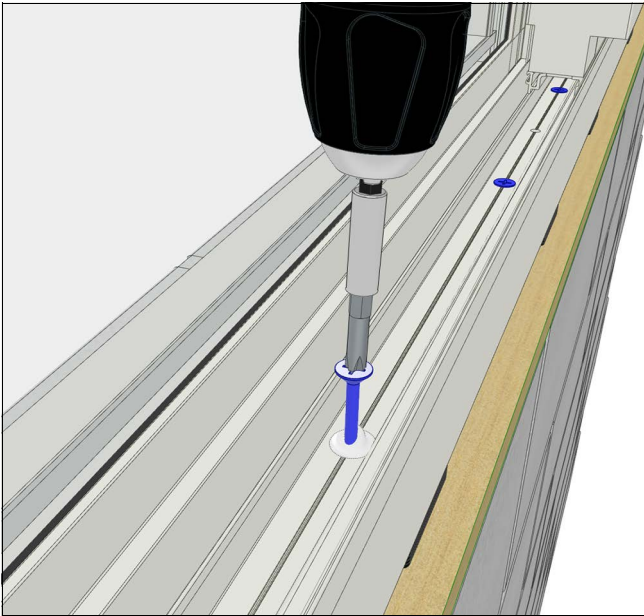

Figure 15

8. Then, seal over the screw heads of the fasteners with additional silicone. See Figure 16.

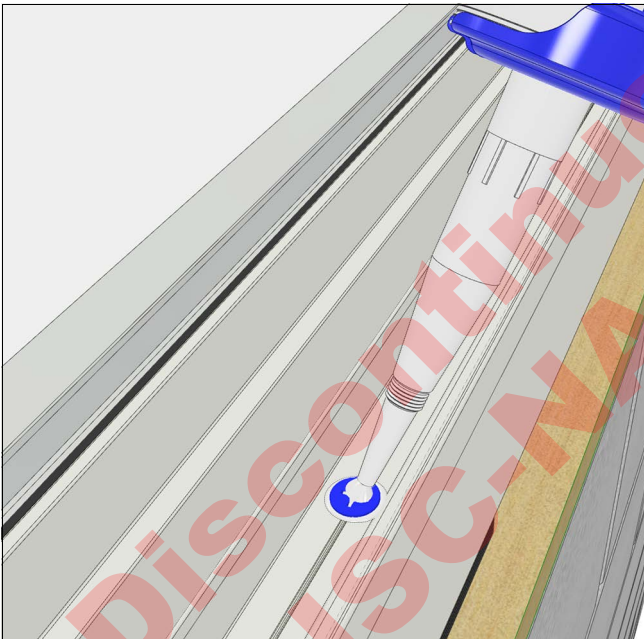

Figure 16

9. Reinstall the Sill Track, and then reinstall Operator Sash. See Figure 17.

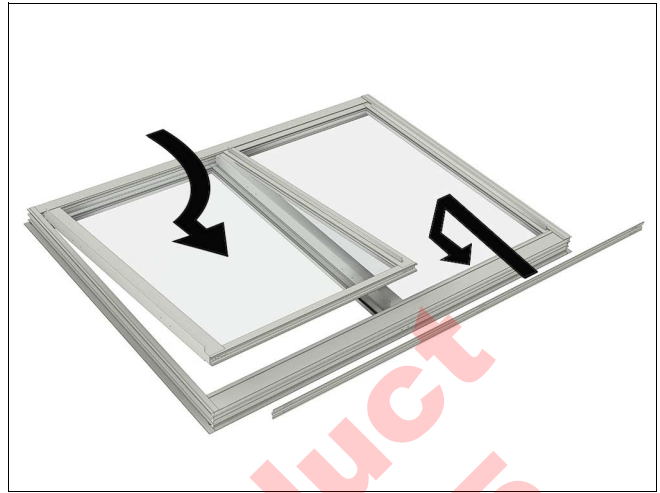

Figure 17

# Typical Anchors

Illustrations show a concrete block opening but apply to typical wood frame construction as well.

Fastener Type	Application	Embedment Depth	Typical Edge Distance	Additional Requirements
1/4" Diameter Ultracon+ by 'Dewalt', or Equivalent  (Fu 164 KSI, Fy - 148 KSI)	2by Wood Bucks or Wood Structures	1-1/2" minimum penetration Into Wood (Head / Jambs)	1" minimum	Anchor placement 6" maximum from frame ends and 12" maximum on center. 8" maximum spacing at meeting stile ends.
	Through 1by Wood Bucks into Concrete or Filled Blocks	1-1/4" minimum embedment into Concrete (Head / Jambs)  1-1/4" minimum embedment into Filled Blocks (Jambs)	1-3/4" minimum	Anchor placement 6" maximum from frame ends and 12" maximum on center. 8" maximum spacing at meeting stile ends.
	Directly into Concrete or Blocks	1-1/4" minimum embedment into Concrete (Head / Jambs) 1 1/4" minimum embedment into Filled Blocks (Jambs)	1-3/4" minimum	Anchor placement 6" maximum from frame ends and 12" maximum on center. 8" maximum spacing at meeting stile ends.
#14 SMS or Self Driving Screws	Metal Structures	(3) Threads minimum Penetration Beyond Substrate Aluminum: 1/8" thick minimum (6063-T5 Min.) Steel*: 1/8" thick minimum (Fy = 36 KSI minimum)	1/2" minimum	Anchor placement 6" maximum from frame ends and 12" maximum on center. 8" maximum spacing at meeting stile ends.
#12 SMS or Self Drilling Screws  (Grade 2 CRS)	F.B.C. Approved Mullions	(3) Threads minimum Penetration beyond substrate Aluminum: 1/8" thick minimum (6063-T5 minimum) Steel*: 1/8" thick minimum (Fy = 36 KSI minimum)	1/2" minimum	Anchor placement 6" maximum from frame ends and 12" maximum on center. 8" maximum spacing at meeting stile ends.
For additional material applications, refer to Florida Product Approval (See Abstract or Technical Specifications).				
* Steel in contact with aluminum to be plated or painted.				

## Continuous Air Barrier Systems-Preparing the Opening

**NOTE:** This does not apply to self-adhering WRB sheathing systems.

1. Make horizontal cuts to the Weather Resistive Barrier (WRB) across the top and bottom of the Rough Opening. Make a vertical cut down the center of the RO, then make 45 degree cuts away from the corners of the top of the RO. See Figure 18. Trim up from the bottom corners 2" and then make an additional horizontal cut about 3-1/2" wide.

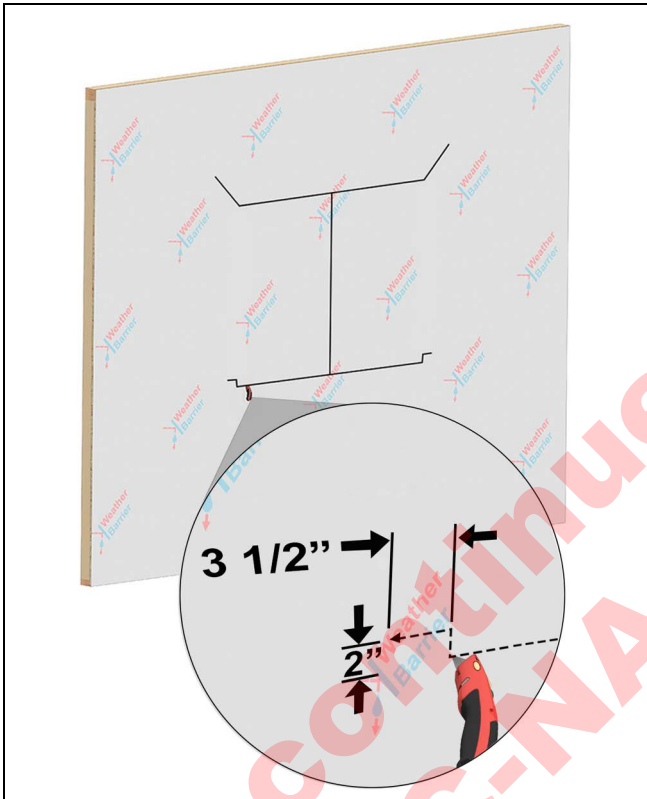

Figure 18

2. Flip the top up and side flaps away and tack temporarily. See Figure 19.

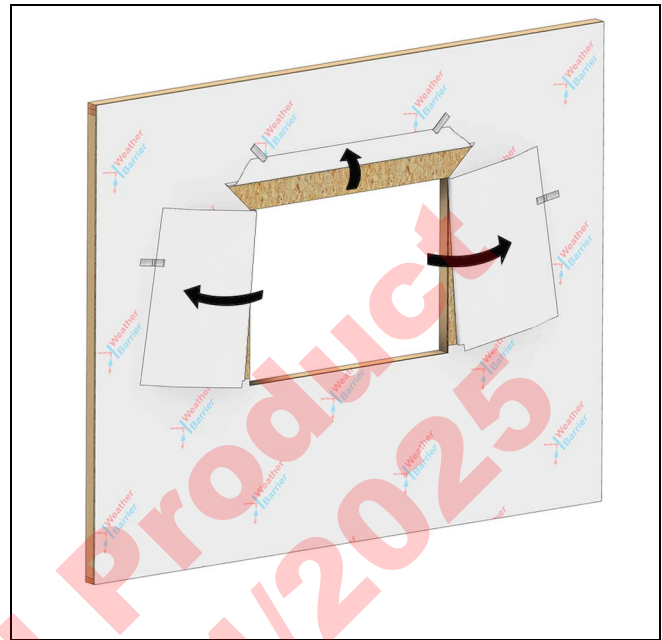

Figure 19

3. **Type III Sill Pan Flash:** Apply self sealing flexible membrane slope. See Figure 20.

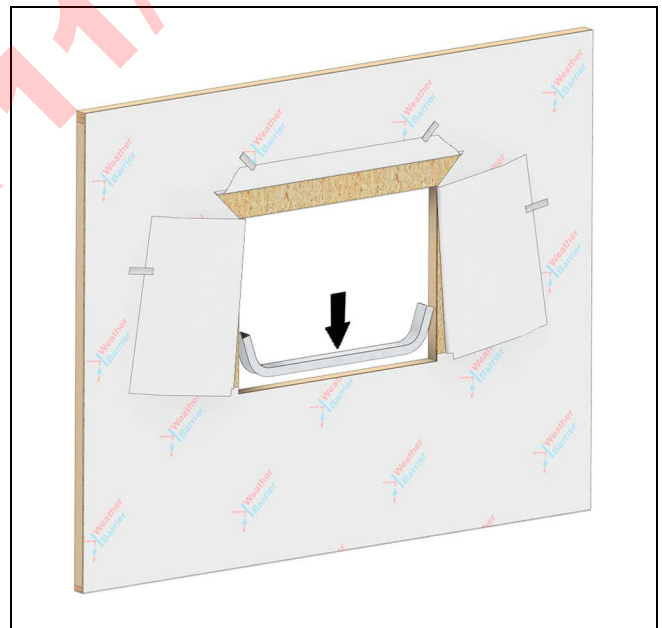

Figure 20

**NOTE:** Some situations call for an upturned leg at the interior. If that is the case, do so using the excess sill flashing membrane to the interior.

4. Wrap side flaps to the interior and staple in place about 1-1/2" from the interior edge of the opening. Cut the excess off near the staple so that a 1" to 1-1/2" strip of bare wood is exposed. Tape this edge with seam seal tape. See Figure 21.

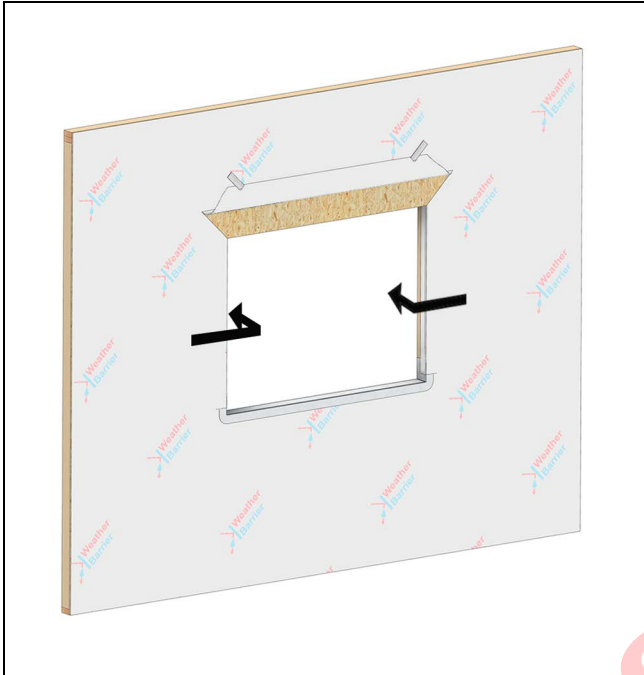

Figure 21

5. Apply seam seal tape over the corners. Place plastic or composite shims at the ends and in the middle of the RO to counter the slope of the sill wedge and support the unit. Fasten with adhesive or finish nails. If using finish nails, place adhesive under shim where the nail will penetrate. See Figure 22.

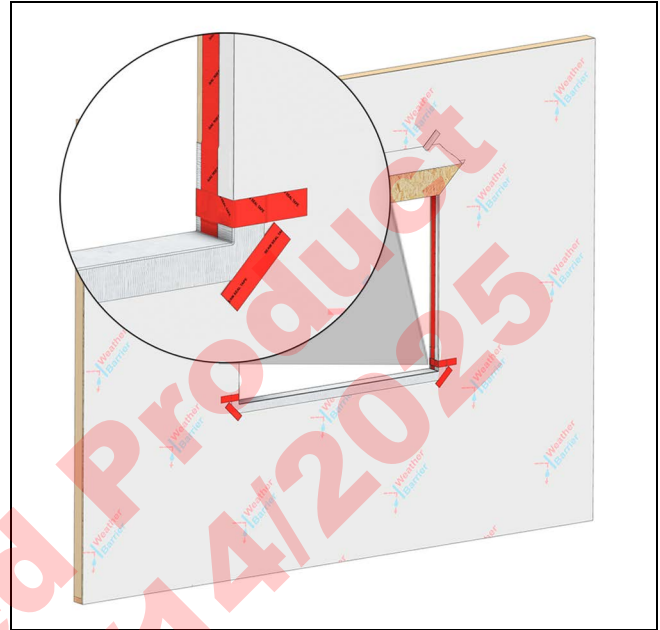

Figure 22

## Flashing the Installation

### IMPORTANT

Follow the flashing tape manufacturer's recommended instructions for attaching to the building materials under the WRB. For example, priming wet or frozen wood, application temperature, etc.

**1. Optional Skirt:** Install an optional "skirt" in applications with exposure to wind driven rain/climate. Use flashing material or a 12" strip of WRB and attach to the sill, overlapping at least half of the front face of the flange. See Figure 23.

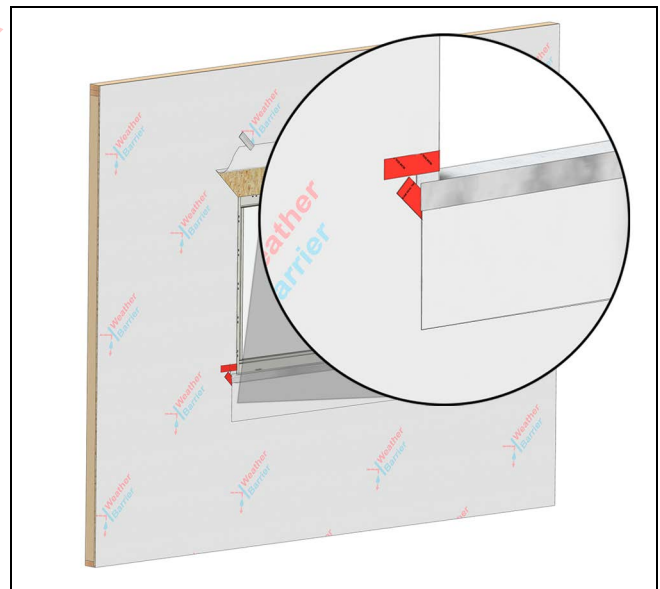

Figure 23

**2.** Lap vertical strips of adhesive flashing tape onto the unit and out over the WRB. See Figure 24.

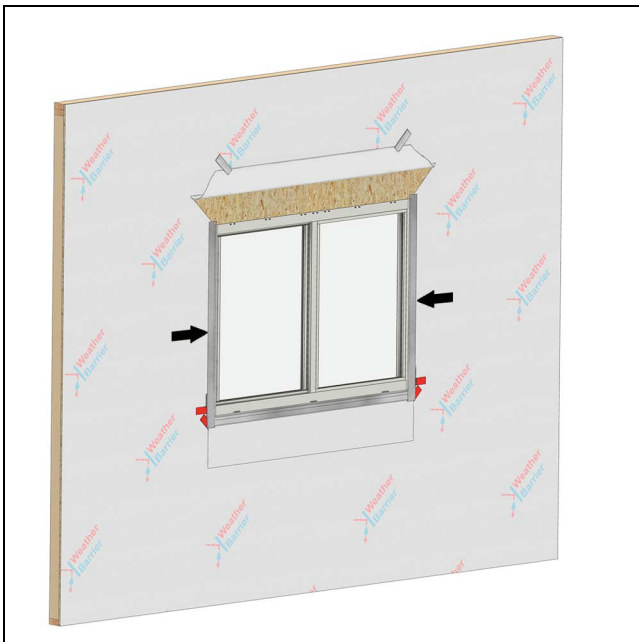

Figure 24

3. Install another layer of adhesive membrane lapping onto the head jamb of the unit and over the sheathing. The membrane flashing at the head jamb should extend and cover the flashing previously installed at the jamba. See Figure 25.

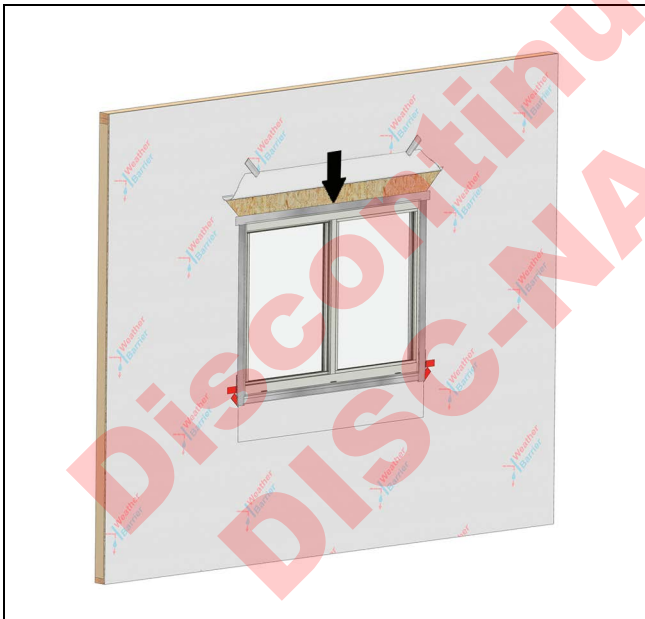

Figure 25

4. Tape the top edge of the head jamb flashing with seam seal tape. See Figure 26.

*NOTE: This does not apply to self adhered WRB.*



Figure 26

5. Fold the head jamb WRB down over the head jamb flashing. Apply seam seal tape over the diagonal cut in the WRB. Make sure the seam seal tape laps onto the unit or casing. Tape any seams and fasteners directly above the unit with seam seal tape. See Figure 27.

*NOTE: This does not apply to self adhered WRB.*

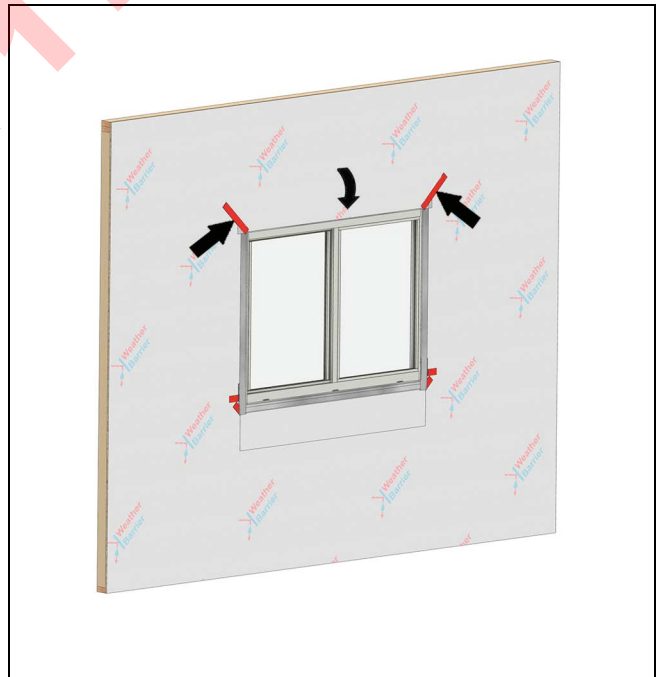

Figure 27

# Technical Specifications

**The following details are specified for proper installation and for the unit to meet the advertised Design Pressure (DP) rating.**

- Must comply with all product installation requirements specified on:
    - Coastline Glider IZ4 - FL33619.1 and FL33619.2
  - For flanged units, Rough Opening (RO) Width and Height shall be 1/2" wider and taller than the unit's inside frame measurement. RO is 1/2" less than outside frame measurement.
  - Wood bucks and buck fasteners by others, must be designed and installed adequately to transfer applied product loads to the building structure.
  - Marvin recommends the use of sloped sills on all concrete openings (either pre-cast or poured).
  - Construct framing from treated lumber and fasten to the masonry opening jambs, header, and sill. This framing must be designed (and anchored to the opening) properly to withstand certified and advertised Design Pressure (DP) ratings for your unit.
  - Follow local codes for sealing and water management details.
  - For installations in typical wood frame construction (with sheathing and building paper or air barrier material) where a continuous air barrier system is used, refer to most recent version of ASTM E2112 or reference the "Continuous Air Barrier Systems" section for details on preparing the rough opening and sealing the installation.
  - Properly flash and/or seal all windows at the exterior perimeter. Sealants used for installation must be minimum Grade NS Class 25 per ASTM C920 and compatible with the building exterior, window exterior surface, and flashing/ water management materials.
  - Flashing materials must comply with ASTM E2112, and be compatible with all materials used in installation including any potential panning systems, air barriers and building papers, sheathing, and the window unit.
  - Optional foams used for installation must be low expansion only. Foam and foam application must comply with ASTM E2112.
  - Shims are required between the window frame and framing members at all locking points and at every point of attachment as well as at all points detailed within these instructions.
- All shims to be high impact, non-metallic and non-compressible.
  - Fasteners penetrating chemically treated lumber must be a minimum of 0.90 oz/ft<sup>2</sup> zinc hot dipped galvanized or stainless-steel type 304 or 316.
  - Materials including (but not limited to) steel / metal screws, that contact other dissimilar materials shall meet the requirements of current adopted version of the Florida Building Code and adopted standards.