

BOWS AND BAYS

Table of Contents

	PAGE
History	3
Ultimate Casement Bow and Bay	
Part Identification – Clad	
Clad Ultimate Casement Bow or Bay	12
Clad Ultimate Casement 45° Bay	13
Clad Ultimate Casement 90° Bay	14
Clad Ultimate Casement Bow	15
Clad Ultimate Push Out Casement Bow or Bay	16
Clad Ultimate Push Out Casement 45° Bay	17
Clad Ultimate Push Out Casement 90° Bay	18
Clad Ultimate Push Out Casement Bow	19
Part Identification – Wood	
Wood Ultimate Casement Bow or Bay	20
Wood Ultimate Casement 45° Bay	21
Wood Ultimate Casement 90° Bay	22
Wood Ultimate Casement Bow	23
Wood Ultimate Push Out Casement Bow or Bay	24
Wood Ultimate Push Out Casement 45° Bay	25
Wood Ultimate Push Out Casement 90° Bay	26
Wood Ultimate Push Out Casement Bow	27
Casemaster Bow and Bay	
Part Identification – Clad	
Clad Casemaster Bow or Bay	8
Clad Casemaster 45° Bay	9
Clad Casemaster 90° Bay	10
Clad Casemaster Bow	11
Part Identification – Wood	
Wood Casemaster Bow or Bay	4
Wood Casemaster 45° Bay	5
Wood Casemaster 90° Bay	6
Wood Casemaster Bow	7

	PAGE
Ultimate Double Hung Bay	
Part Identification – Head Jamb and Sill Details	
Clad Ultimate Double Hung Bay	30
Wood Ultimate Double Hung Bay	28
Part Identification – Jamb Details	
Clad Ultimate Double Hung Bay	31
Wood Ultimate Double Hung Bay	29
Wood 90° Bent Glass Triangle Bay	32
Replacement Parts	33
Obsolete	
Obsolete Sun Bay Information	37

ATTENTION:

- Specification and technical data are subject to change without notice.
- Numbers listed in parentheses () are metric equivalents in millimeters rounded to the nearest whole number.

PRODUCED	UNIT TYPE	FEATURES OR CHANGES	STATUS
1962	Casement Bows	Introduced 4, 5 and 6 wide bow units with head and seat board.	1979
1971	Wood Double Hung Bays	Introduced 30 and 45 degree bay units with head and seat board.	Present
1974	Wood Casemaster Bows and Bay	Introduced 45 degree bay and 5 wide bow units with head and seat board.	Present
1976	Wood Casemaster Bow	Added 4 and 6 wide bow units.	Present
1978	Clad Casemaster Bows and Bay	Introduced 45 degree bay and 4, 5 and 6 wide bow units with head and seat board.	Present
1979	Clad Double Hung Bay	Introduced 45 degree bay unit with head and seat board.	Present
1981	Wood Casemaster and Double Hung Bays	Introduced 60 degree bay units with head and seat board.	Present
1982	Wood Casemaster Bays	Introduced 30 and 90 degree bay units with head and seat board. The 90 degree bay features 1 7/8" top and side flat casing.	Present
1983	Clad Double Hung and Clad Casemaster Bays	Introduced 30 degree bay units with head and seat board.	Present
1983	Sun Bays	Unit featured a 90 degree bay configuration with polygon shaped operating flankers, 1" direct glazed center section and a 1" direct glazed sloped top. Unit was complete with seat board, lever operators, cam locks, butt hinges, 3" top flat casing and 1 1/2" side flat casing.	1994
1987	Clad Casemaster Bay	Introduced 90° bay units with head and seat board.	Present
1991	Wood 90 Degree Bent Glass Triangle Bay	Unit features 1" direct glazed bent glass, clear brick mould casing and clear sill. Head and seat board included.	1999
1992	Sun Bays	Weather strip upgraded.	1994
2003	Wood and Clad Casemaster Bow & Bay	3/31/03 Satin Taupe (TP) hardware replaces bronze as standard. New interior stops, Satin Taupe aluminum screens, optional wood surround screens are available. New screen location and fastening system. New one-piece clad sash extrusion.	Present
	Wood and Clad Ultimate Double Hung	3/31/03 Satin Taupe (TP) hardware replaces bronze as standard.	Present
	Wood and Clad Casemaster Bow & Bay	4/14/03 Newly designed Satin Taupe (TP) folding handle is standard.	Present
2004	Wood and Clad Bow & Bay	1/2004 Added Oil Rubbed Bronze and Satin Chrome to available hardware finishes	Present
2005	Wood and Clad Bow & Bay	2/2005 Added cable support system	Present
2008	Clad Bow & Bay	7/28/2008 Added Clad Ultimate Casement. Mixed grain Douglas fir is now a standard option.	Present
2009	Wood & Clad Bow & Bay	1/26/2009 Added Wood Ultimate Casement, and wood and clad Ultimate Push out.	Present
2009	All	3/23/2009 Added LoE ³ -366™ as a standard option for all products. Added Cedro Macho as a standard option for all clad products.	Present
2011	All	04/25/2011 Added LoE-180™ as a standard option for all products. White painted interior finish option introduced for all products	Present
2012	All	12/17/2012 Clear interior finish option introduced for all products.	Present
2013	All	04/29/2013 Introduced interior stain options. Stain colors are Wheat, Honey, Leather, Hazelnut, Cabernet and Espresso.	Present
2016	All	10/31/2016 Obsolescence of the wood species Cedro Macho for all products.	Present
2017	All	10/30/2017 Energy panel colors discontinued with exception of bronze and stone white	Present

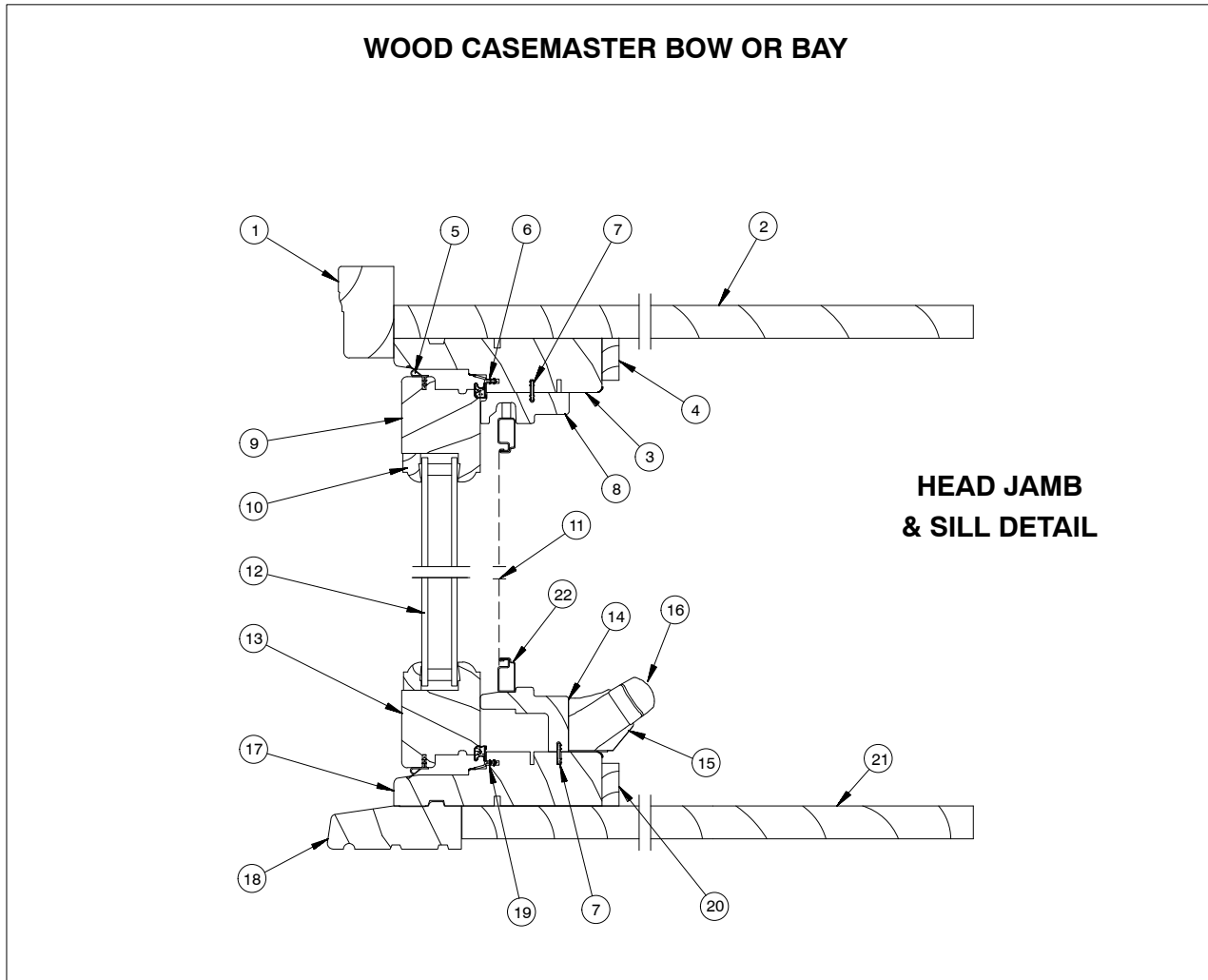

NOTE: Not to scale; specifications subject to change without notice.

- | | | |
|----------------------------|--------------------------|--------------------------|
| 1. Top Brick Mould Casing | 9. Top Rail | 17. Sill |
| 2. Head Board | 10. Glazing Bead | 18. Subsill |
| 3. Head Jamb | 11. Screen Mesh | 19. Sill Weather Strip |
| 4. Top Interior Trim | 12. Insulated Glass | 20. Bottom Interior Trim |
| 5. Sash Weather Strip | 13. Bottom Rail | 21. Seat Board |
| 6. Head Jamb Weather Strip | 14. Hardware Cover | 22. Screen Frame |
| 7. Connecting Barb | 15. Folding Crank Cover | |
| 8. Head Jamb Stop | 16. Folding Crank Handle | |

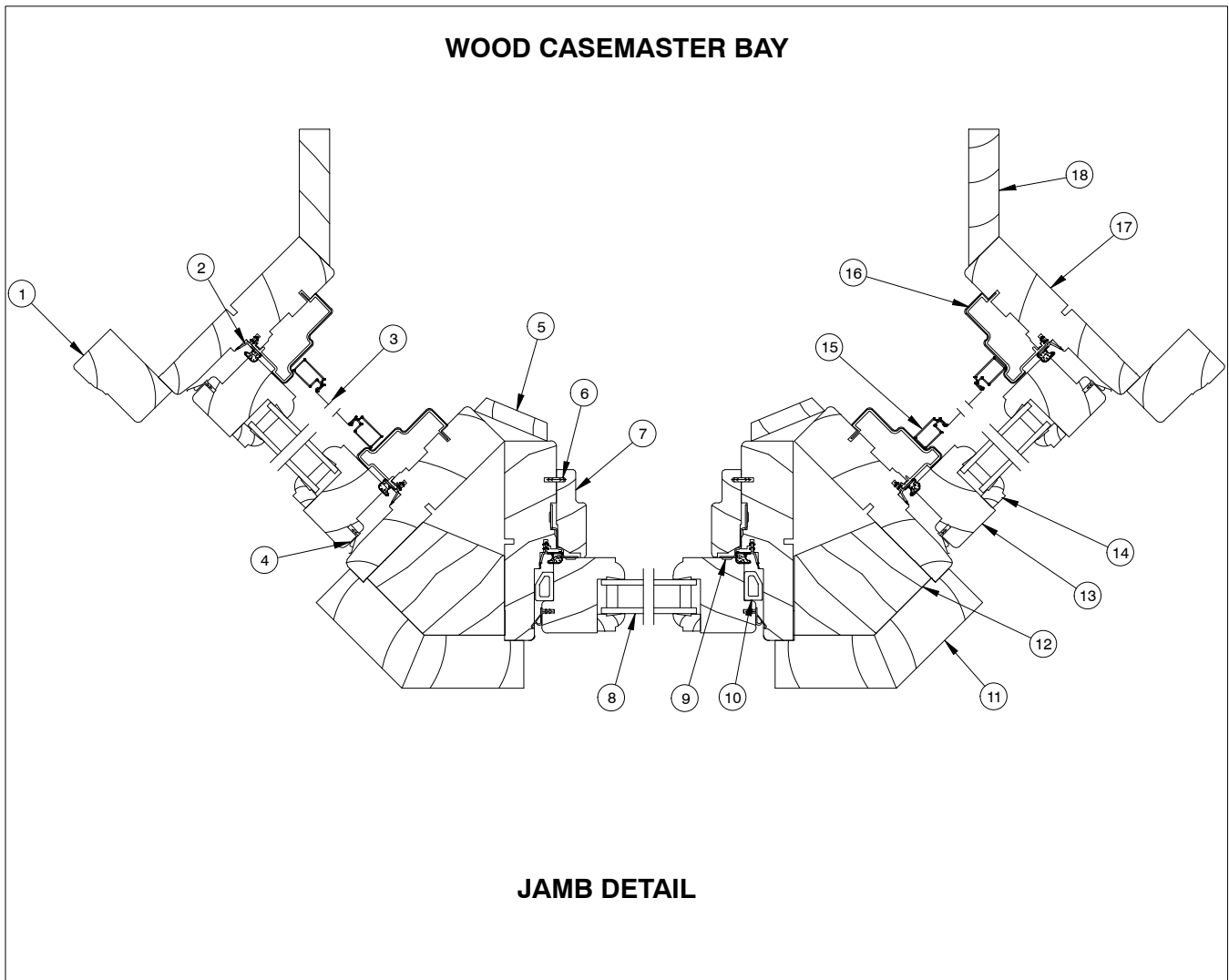

NOTE: Not to scale; specifications subject to change without notice.

- 1. Side Brick Mould Casing
- 2. Frame Weather Strip
- 3. Screen Mesh
- 4. Sash Weather Strip
- 5. Interior Mull Trim
- 6. Connecting Barb
- 7. Stationary Side Stop
- 8. Insulated Glass

- 9. Stationary Jamb Bracket
- 10. Stationary Sash Blocks
- 11. Exterior Mull Casing
- 12. Mull Block
- 13. Stile
- 14. Glazing Bead
- 15. Screen Frame
- 16. Side Stop

- 17. Jamb
- 18. Return Jamb

WOOD CASEMASTER 90° BAY

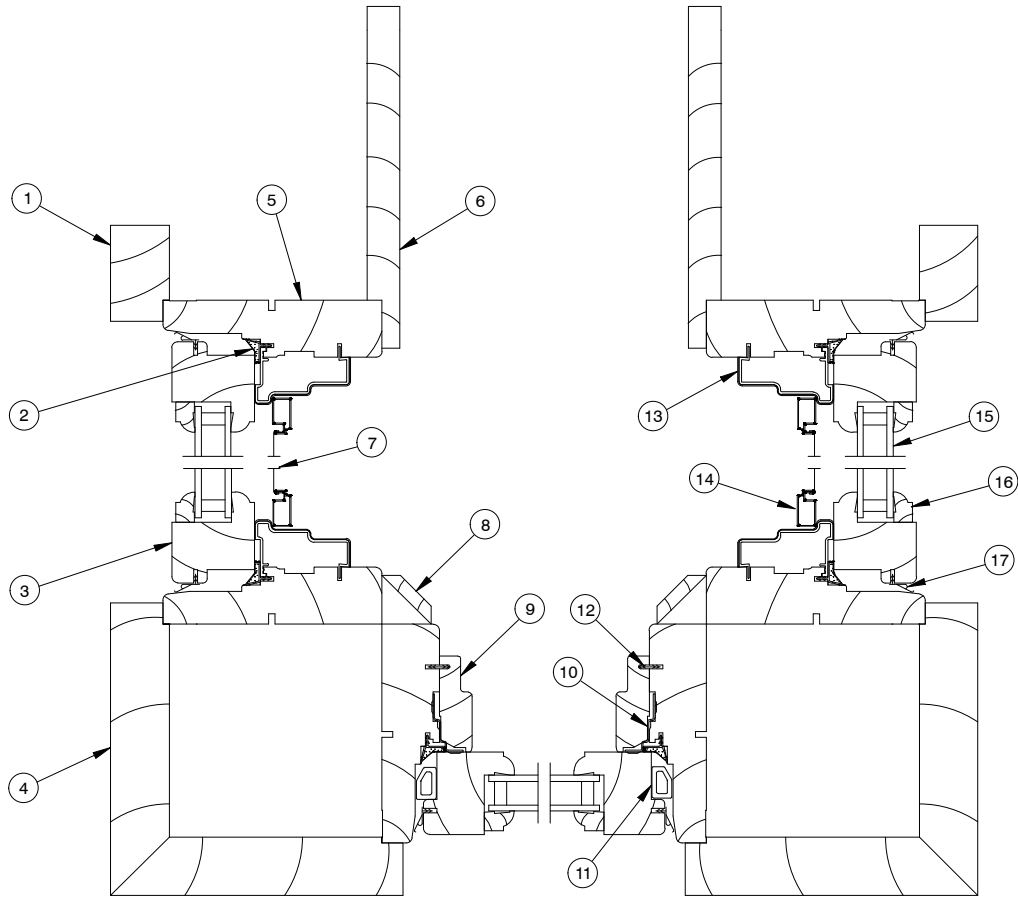

JAMB DETAIL

NOTE: Not to scale; specifications subject to change without notice.

- | | | |
|-------------------------|-----------------------------|------------------------|
| 1. Side Flat Casing | 7. Screen Mesh | 13. Side Stop |
| 2. Frame Weather Strip | 8. Interior Mull Trim | 14. Screen Frame |
| 3. Stile | 9. Stationary Side Stop | 15. Insulated Glass |
| 4. Exterior Mull Casing | 10. Stationary Jamb Bracket | 16. Glazing Bead |
| 5. Jamb | 11. Stationary Sash Block | 17. Sash Weather Strip |
| 6. Return Jamb | 12. Connecting Barb | |

WOOD CASEMASTER BOW

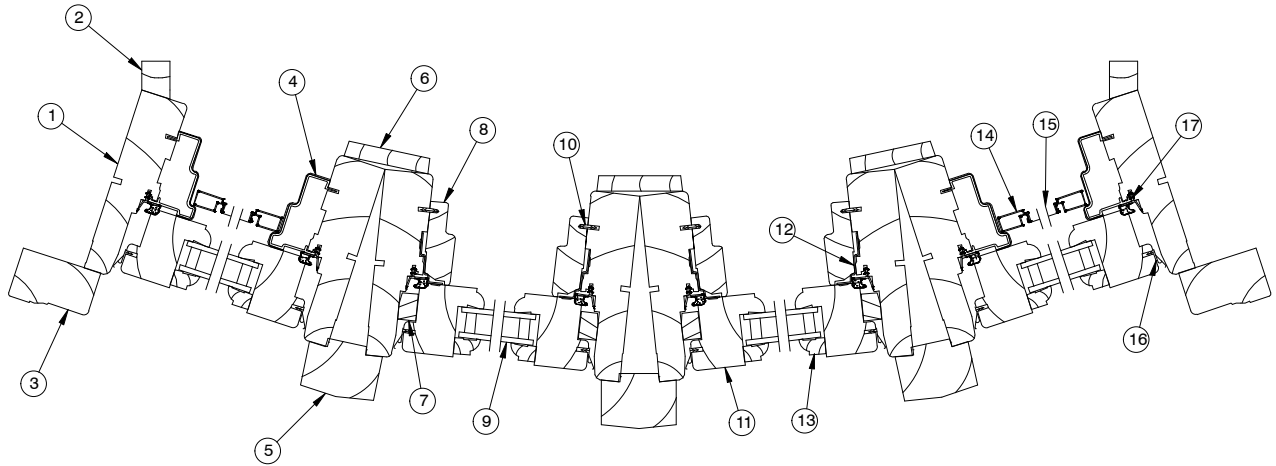

JAMB DETAIL

NOTE: Not to scale; specifications subject to change without notice.

- | | | |
|----------------------------|-----------------------------|-------------------------|
| 1. Jamb | 7. Stationary Sash Block | 13. Glazing Bead |
| 2. Return Jamb | 8. Stationary Side Stop | 14. Screen Frame |
| 3. Side Brick Mould Casing | 9. Insulated Glass | 15. Screen Mesh |
| 4. Side Stop | 10. Connecting Barb | 16. Sash Weather Strip |
| 5. Exterior Mull Casing | 11. Stile | 17. Frame Weather Strip |
| 6. Interior Mull Trim | 12. Stationary Sash Bracket | |

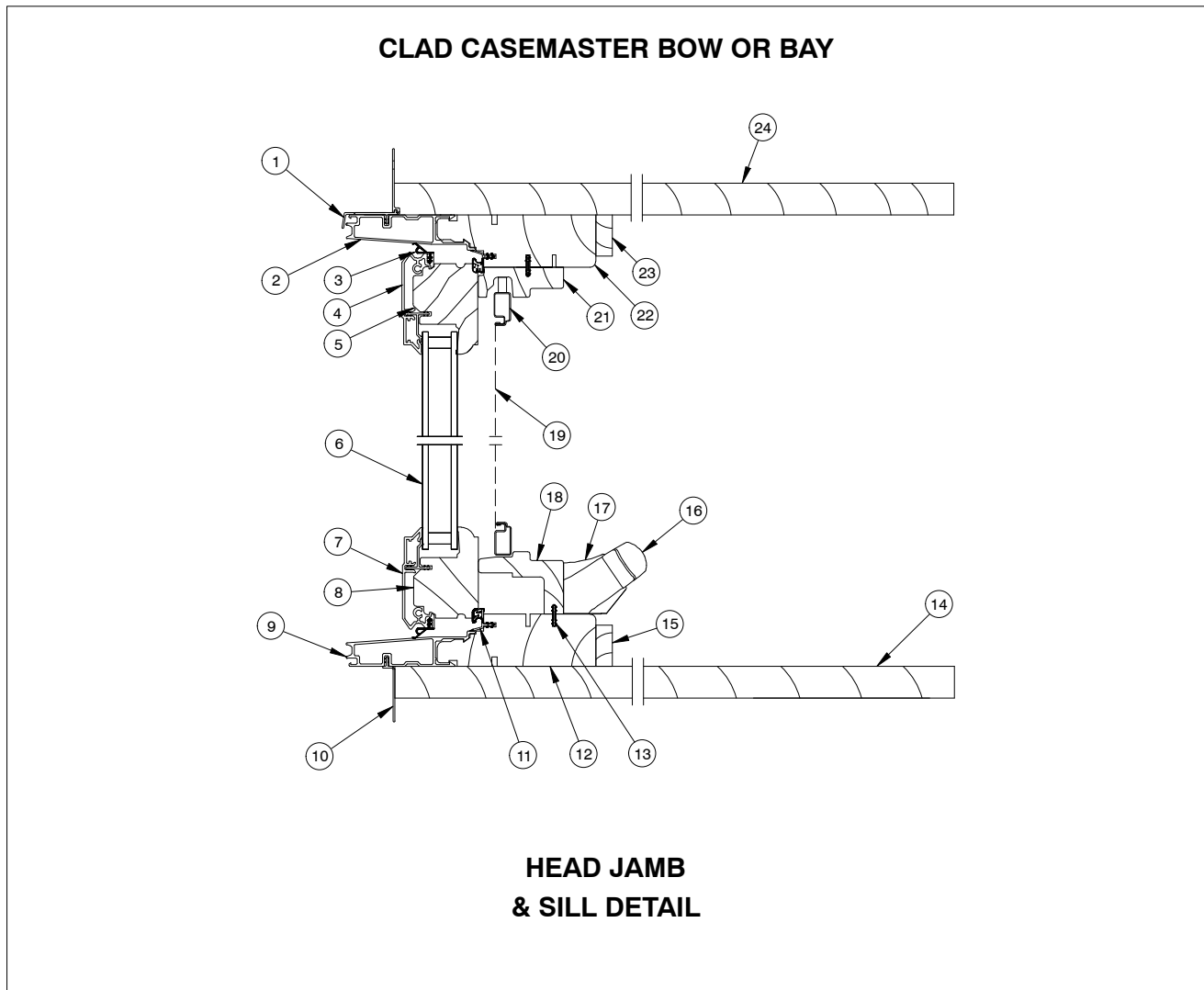

NOTE: Not to scale; specifications subject to change without notice.

- | | | |
|-----------------------------------|--------------------------|-----------------------|
| 1. Head Jamb Nailing Fin/Drip Cap | 10. Sill Nailing Fin | 19. Screen Mesh |
| 2. Head Jamb Cladding | 11. Frame Weather Strip | 20. Screen Frame |
| 3. Sash Weather Strip | 12. Sill | 21. Head Jamb Stop |
| 4. Top Rail Cladding | 13. Connecting Barb | 22. Head Jamb |
| 5. Top Rail | 14. Seat Board | 23. Top Interior Trim |
| 6. Insulated Glass | 15. Bottom Interior Trim | 24. Head Board |
| 7. Bottom Rail Cladding | 16. Folding Crank Handle | |
| 8. Bottom Rail | 17. Folding Crank Cover | |
| 9. Sill Cladding | 18. Hardware Cover | |

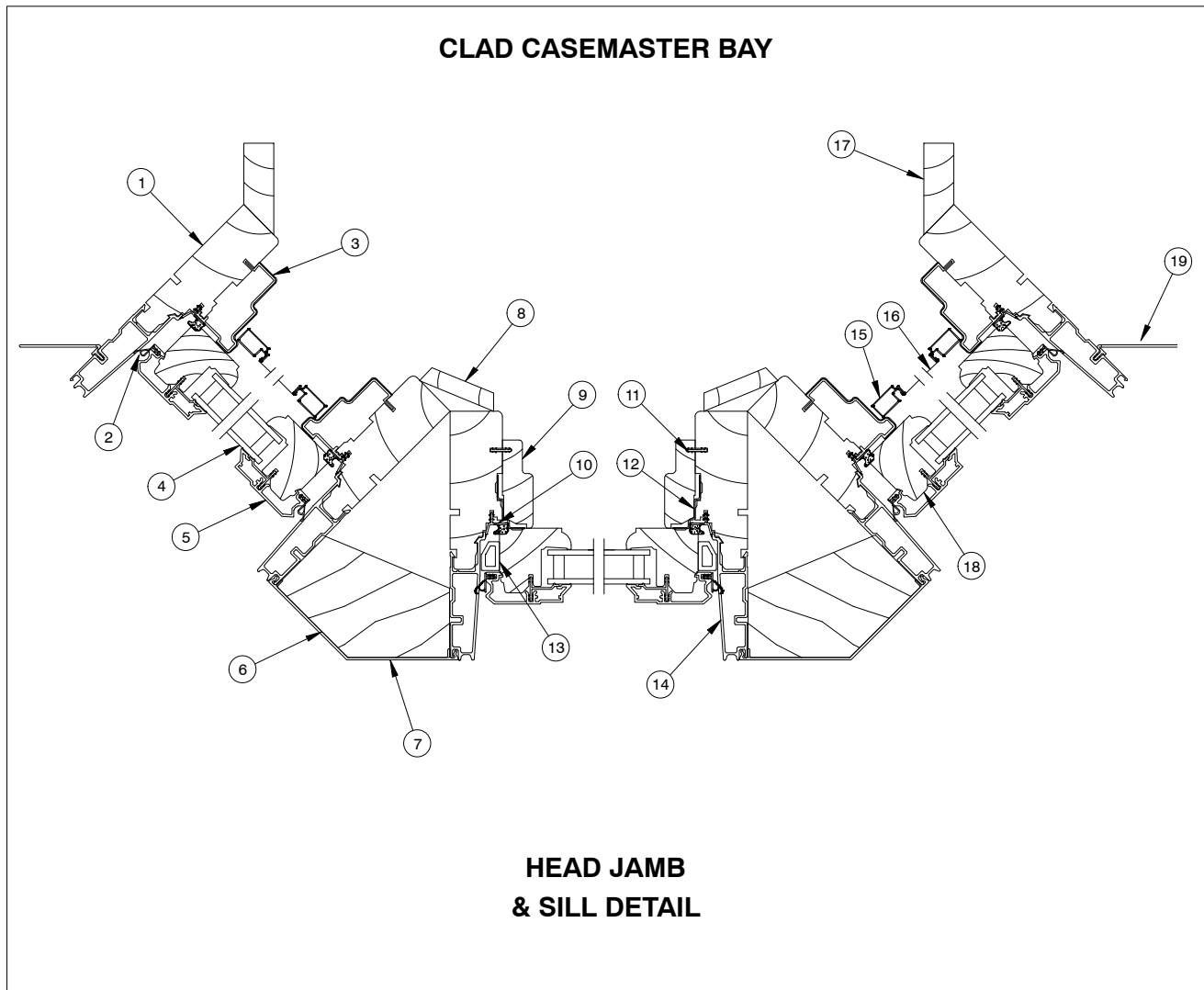

NOTE: Not to scale; specifications subject to change without notice.

- | | |
|-------------------------|-----------------------------|
| 1. Jamb | 10. Frame Weather Strip |
| 2. Sash Weather Strip | 11. Connecting Barb |
| 3. Side Stop | 12. Stationary Jamb Bracket |
| 4. Insulated Glass | 13. Stationary Sash Block |
| 5. Stile Cladding | 14. Jamb Cladding |
| 6. Mull Block | 15. Screen Frame |
| 7. Mull Cap | 16. Screen Mesh |
| 8. Interior Mull Trim | 17. Return Jamb |
| 9. Stationary Side Stop | 18. Stile |
| | 19. Jamb Nailing Fin |

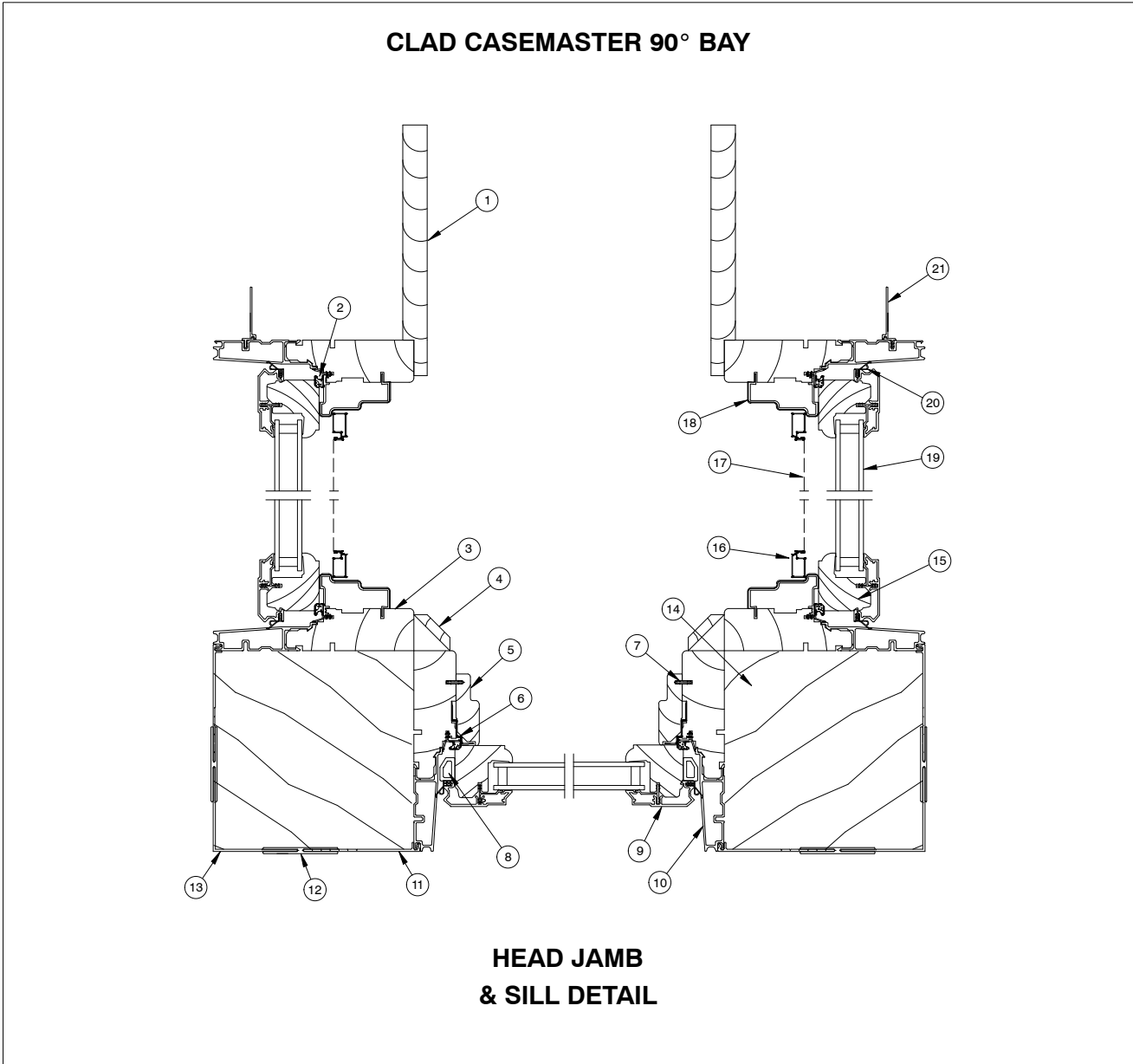

NOTE: Not to scale; specifications subject to change without notice.

- | | | |
|----------------------------|--------------------------------|------------------------|
| 1. Return Jamb | 10. Jamb Cladding | 19. Insulated Glass |
| 2. Frame Weather Strip | 11. Clad Frame Expander | 20. Sash Weather Strip |
| 3. Jamb | 12. Clad Mull Expander | 21. Jamb Nailing Fin |
| 4. Interior Mull Trim | 13. 90 Degree Bay Corner Cover | |
| 5. Stationary Side Stop | 14. Mull Block | |
| 6. Stationary Sash Bracket | 15. Stile | |
| 7. Connecting Barb | 16. Screen Frame | |
| 8. Stationary Sash Block | 17. Screen Mesh | |
| 9. Stile Cladding | 18. Side Stop | |

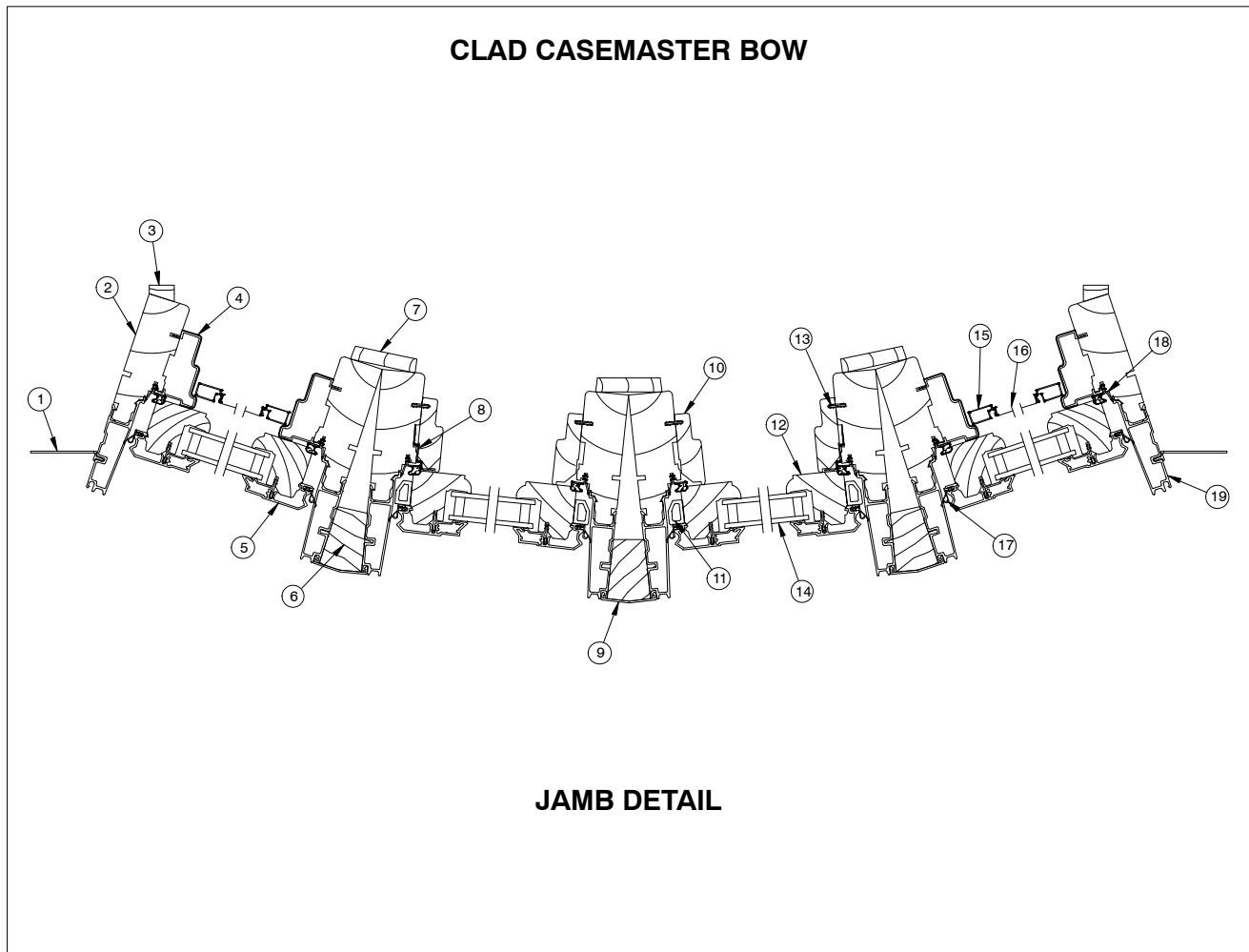

NOTE: Not to scale; specifications subject to change without notice.

- | | | |
|----------------------------|---------------------------|-------------------------|
| 1. Jamb Nailing Fin | 9. Clad Mull Cap | 17. Sash Weather Strip |
| 2. Jamb | 10. Side Stop | 18. Frame Weather Strip |
| 3. Return Jamb | 11. Stationary Sash Block | 19. Jamb Cladding |
| 4. Side Stop | 12. Stile | |
| 5. Stile Cladding | 13. Connecting Barb | |
| 6. Mull Block | 14. Insulated Glass | |
| 7. Interior Mull Trim | 15. Screen Frame | |
| 8. Stationary Sash Bracket | 16. Screen Mesh | |

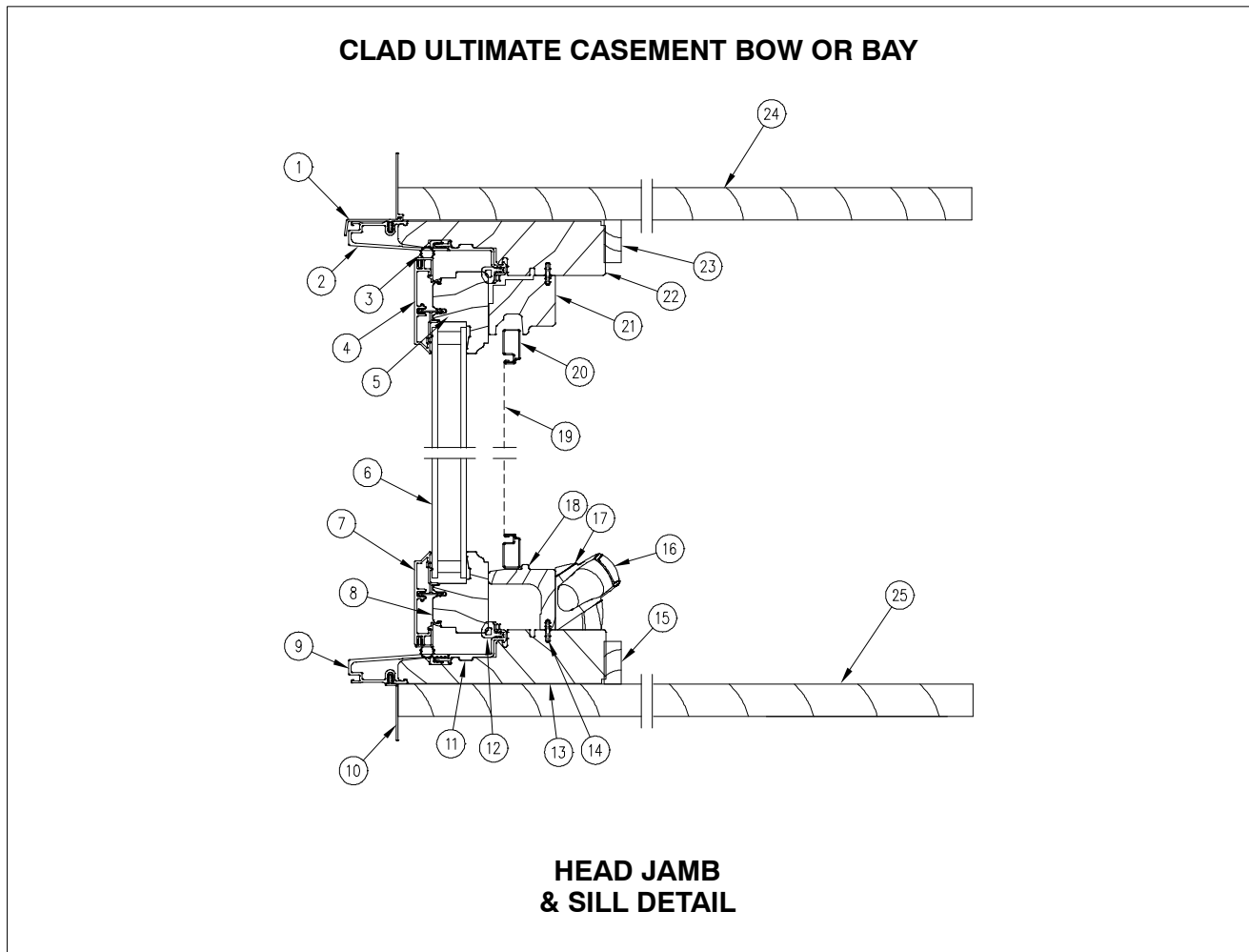

NOTE: Not to scale; specifications subject to change without notice.

- | | | |
|-----------------------------------|--------------------------|-----------------------|
| 1. Head Jamb Nailing Fin/Drip Cap | 10. Sill Nailing Fin | 19. Screen Mesh |
| 2. Head Jamb Cladding | 11. Frame Thermal Break | 20. Screen Frame |
| 3. Sash Weather Strip | 12. Frame Weather Strip | 21. Head Jamb Stop |
| 4. Top Rail Cladding | 13. Sill | 22. Head Jamb |
| 5. Top Rail | 14. Connecting Barb | 23. Top Interior Trim |
| 6. Insulated Glass | 15. Bottom Interior Trim | 24. Head Board |
| 7. Bottom Rail Cladding | 16. Folding Crank Handle | 25. Seat Board |
| 8. Bottom Rail | 17. Folding Crank Cover | |
| 9. Sill Cladding | 18. Hardware Cover | |

CLAD ULTIMATE CASEMENT 45° BAY

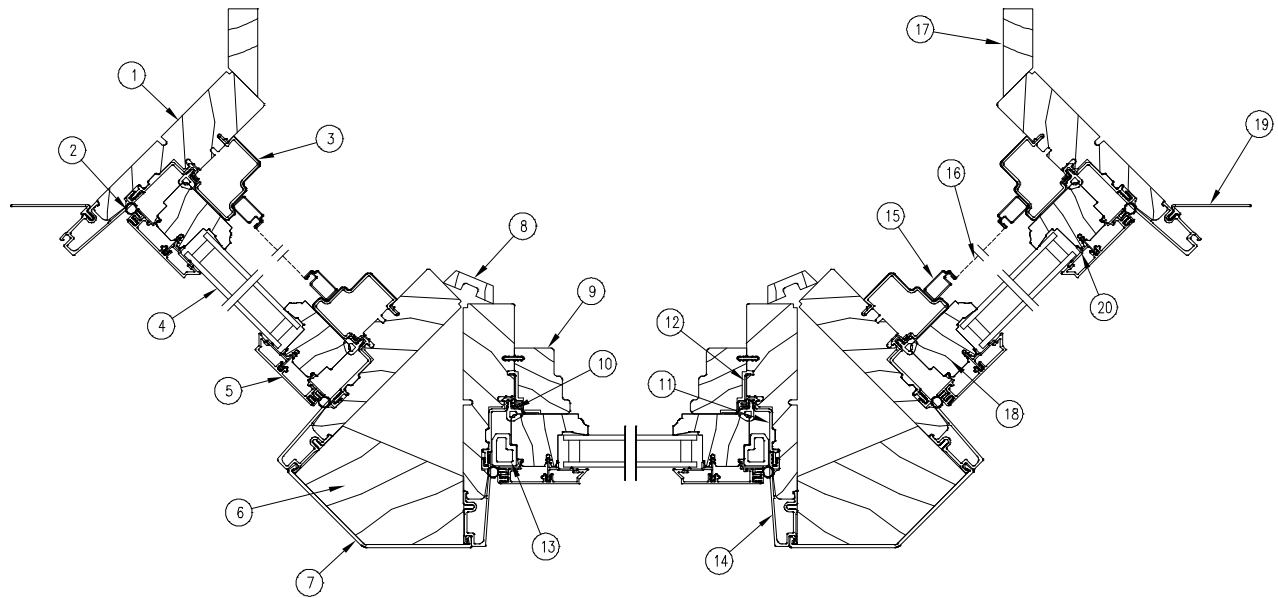

JAMB DETAIL

NOTE: Not to scale; specifications subject to change without notice.

- | | | |
|-----------------------|-----------------------------|-----------------------|
| 1. Jamb | 8. Interior Mull Trim | 15. Screen Frame |
| 2. Sash Weather Strip | 9. Stationary Side Stop | 16. Screen Mesh |
| 3. Side Stop | 10. Frame Weather Strip | 17. Return Jamb |
| 4. Insulated Glass | 11. Thermal Break | 18. Stile |
| 5. Stile Cladding | 12. Stationary Jamb Bracket | 19. Jamb Nailing Fin |
| 6. Mull Block | 13. Stationary Sash Block | 20. Sash Glazing Bead |
| 7. Mull Cap | 14. Jamb Cladding | |

CLAD ULTIMATE CASEMENT 90° BAY

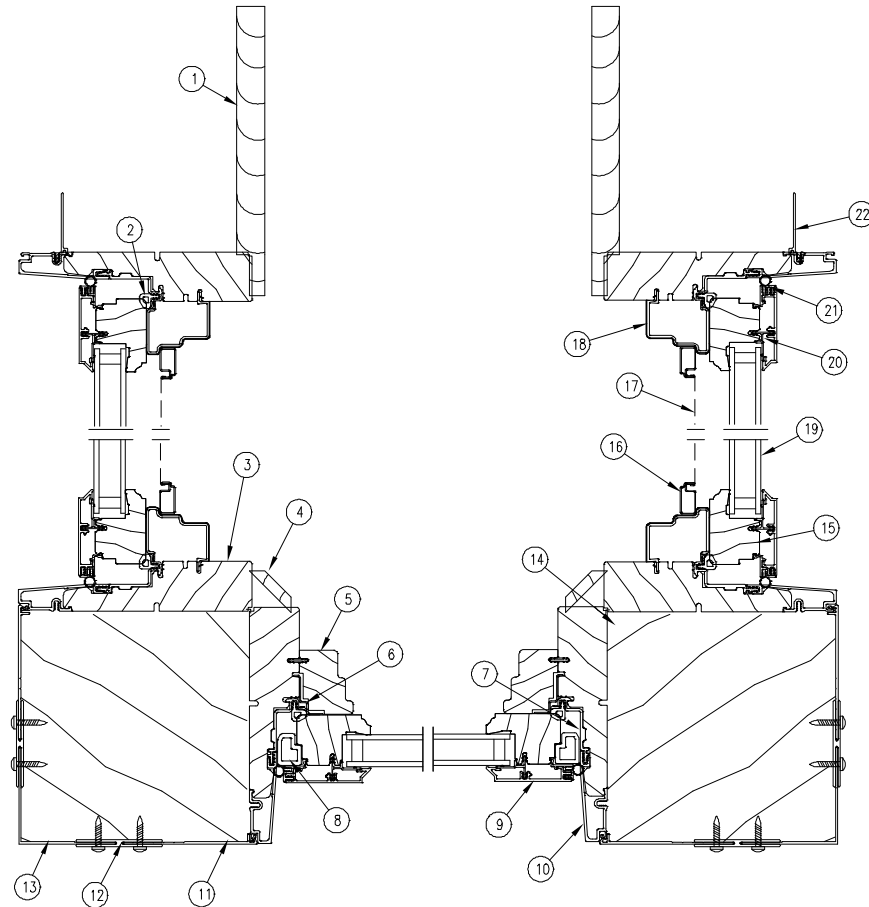

**HEAD JAMB
 & SILL DETAIL**

NOTE: Not to scale; specifications subject to change without notice.

- | | | |
|----------------------------|--------------------------------|------------------------|
| 1. Return Jamb | 10. Jamb Cladding | 19. Insulated Glass |
| 2. Frame Weather Strip | 11. Clad Frame Expander | 20. Sash Glazing Bead |
| 3. Jamb | 12. Clad Mull Expander | 21. Sash Weather Strip |
| 4. Interior Mull Trim | 13. 90 Degree Bay Corner Cover | 22. Jamb Nailing Fin |
| 5. Stationary Side Stop | 14. Mull Block | |
| 6. Stationary Sash Bracket | 15. Stile | |
| 7. Frame Thermal Break | 16. Screen Frame | |
| 8. Stationary Sash Block | 17. Screen Mesh | |
| 9. Stile Cladding | 18. Side Stop | |

CLAD ULTIMATE CASEMENT BOW

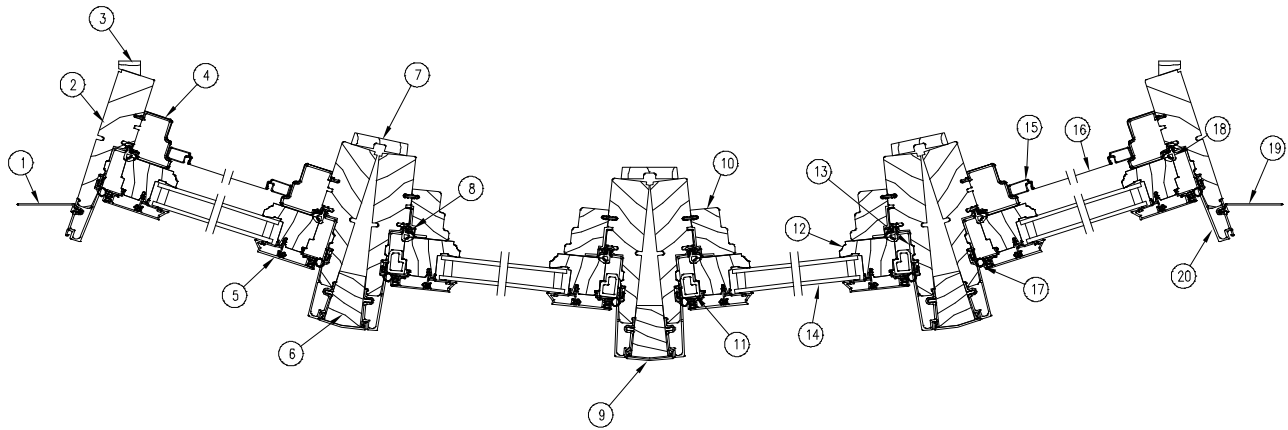

JAMB DETAIL

NOTE: Not to scale; specifications subject to change without notice.

- | | | |
|----------------------------|---------------------------|-------------------------|
| 1. Jamb Nailing Fin | 9. Clad Mull Cap | 17. Sash Weather Strip |
| 2. Jamb | 10. Side Stop | 18. Frame Weather Strip |
| 3. Return Jamb | 11. Stationary Sash Block | 19. Jamb Nailing Fin |
| 4. Side Stop | 12. Stile | 20. Jamb Cladding |
| 5. Stile Cladding | 13. Frame Thermal Break | |
| 6. Mull Block | 14. Insulated Glass | |
| 7. Interior Mull Trim | 15. Screen Frame | |
| 8. Stationary Sash Bracket | 16. Screen Mesh | |

CLAD ULTIMATE PUSH OUT CASEMENT BOW OR BAY

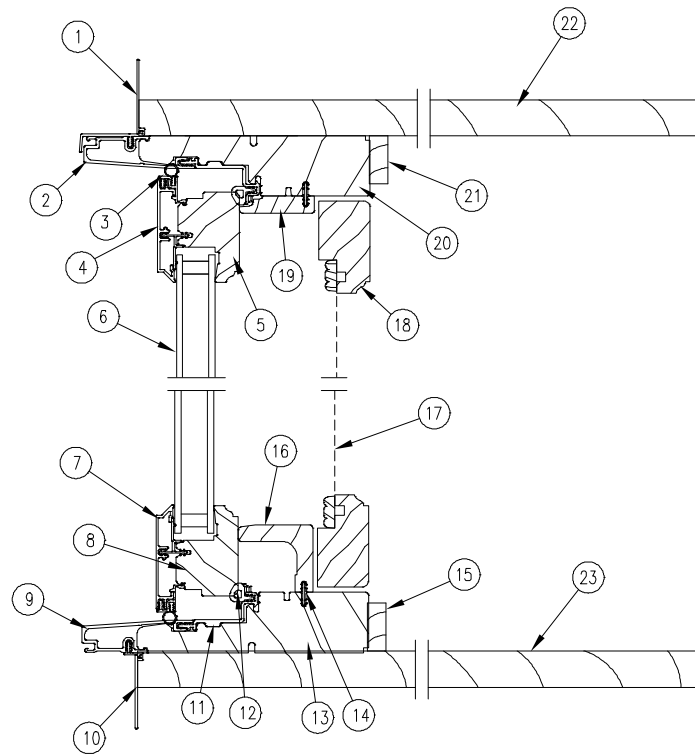

**HEAD JAMB
 & SILL DETAIL**

NOTE: Not to scale; specifications subject to change without notice.

- | | | |
|-----------------------------------|--------------------------|-----------------------|
| 1. Head Jamb Nailing Fin/Drip Cap | 10. Sill Nailing Fin | 19. Head Jamb Stop |
| 2. Head Jamb Cladding | 11. Frame Thermal Break | 20. Head Jamb |
| 3. Sash Weather Strip | 12. Frame Weather Strip | 21. Top Interior Trim |
| 4. Top Rail Cladding | 13. Sill | 22. Head Board |
| 5. Top Rail | 14. Connecting Barb | 23. Seat Board |
| 6. Insulated Glass | 15. Bottom Interior Trim | |
| 7. Bottom Rail Cladding | 16. Sill Cover | |
| 8. Bottom Rail | 17. Screen Mesh | |
| 9. Sill Cladding | 18. Wood Screen Frame | |

CLAD ULTIMATE PUSH OUT CASEMENT 45° BAY

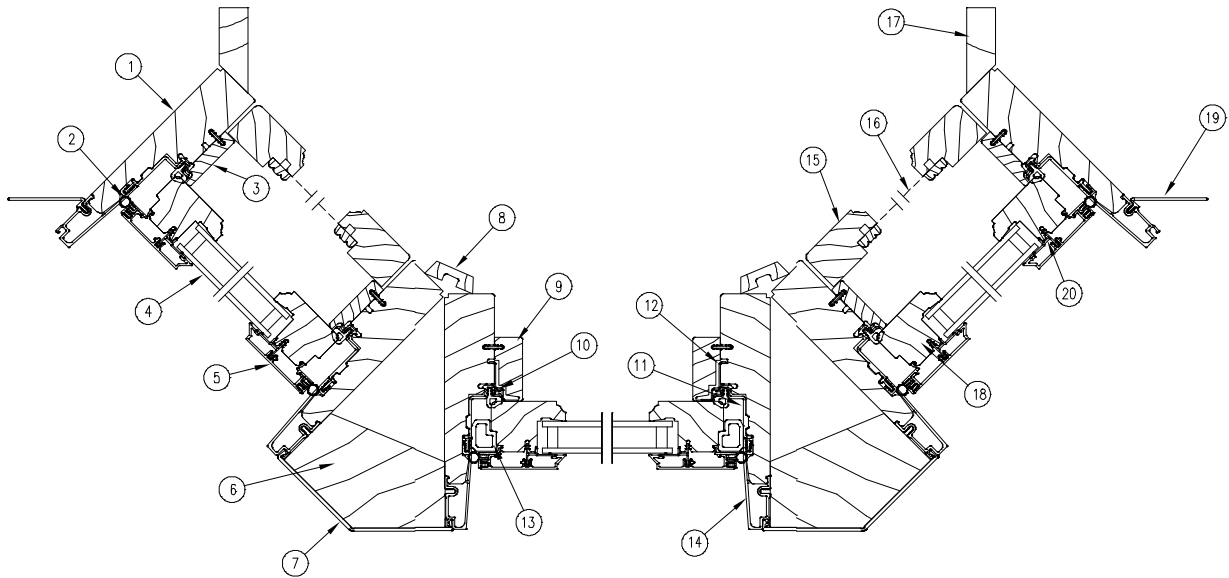

JAMB DETAIL

NOTE: Not to scale; specifications subject to change without notice.

- | | | |
|-----------------------|-----------------------------|-----------------------|
| 1. Jamb | 8. Interior Mull Trim | 15. Screen Frame |
| 2. Sash Weather Strip | 9. Stationary Side Stop | 16. Screen Mesh |
| 3. Side Stop | 10. Frame Weather Strip | 17. Return Jamb |
| 4. Insulated Glass | 11. Thermal Break | 18. Stile |
| 5. Stile Cladding | 12. Stationary Jamb Bracket | 19. Jamb Nailing Fin |
| 6. Mull Block | 13. Stationary Sash Block | 20. Sash Glazing Bead |
| 7. Mull Cap | 14. Jamb Cladding | |

CLAD ULTIMATE PUSH OUT CASEMENT 90° BAY

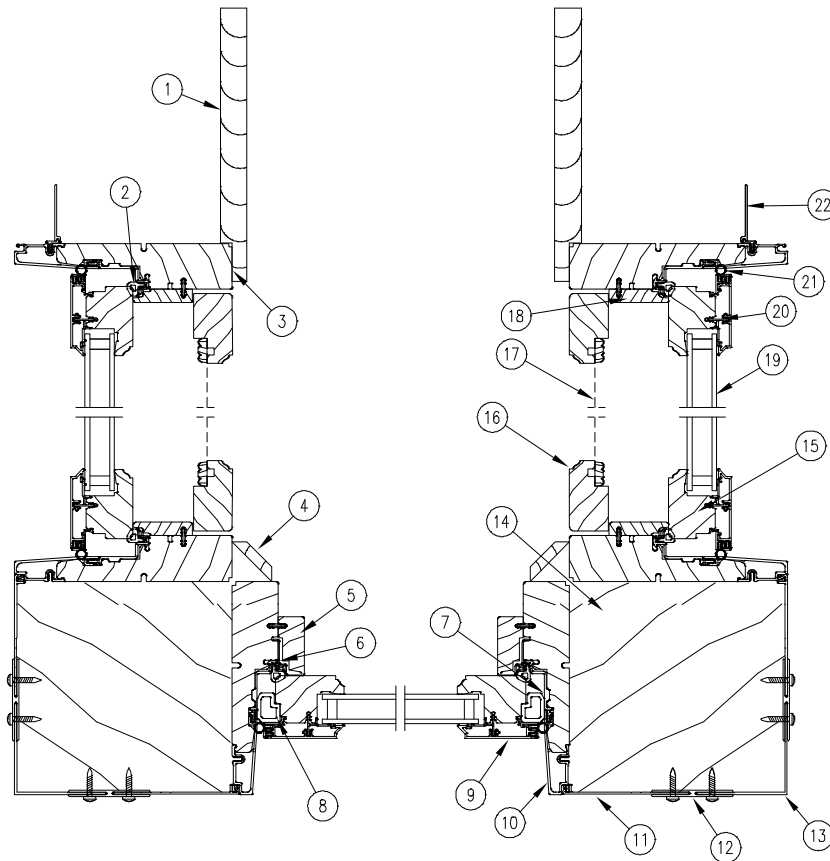

**HEAD JAMB
 & SILL DETAIL**

NOTE: Not to scale; specifications subject to change without notice.

- | | | |
|----------------------------|--------------------------------|------------------------|
| 1. Return Jamb | 10. Jamb Cladding | 19. Insulated Glass |
| 2. Frame Weather Strip | 11. Clad Frame Expander | 20. Sash Glazing Bead |
| 3. Jamb | 12. Clad Mull Expander | 21. Sash Weather Strip |
| 4. Interior Mull Trim | 13. 90 Degree Bay Corner Cover | 22. Jamb Nailing Fin |
| 5. Stationary Side Stop | 14. Mull Block | |
| 6. Stationary Sash Bracket | 15. Stile | |
| 7. Frame Thermal Break | 16. Screen Frame | |
| 8. Stationary Sash Block | 17. Screen Mesh | |
| 9. Stile Cladding | 18. Jamb Stop | |

CLAD ULTIMATE PUSH OUT CASEMENT BOW

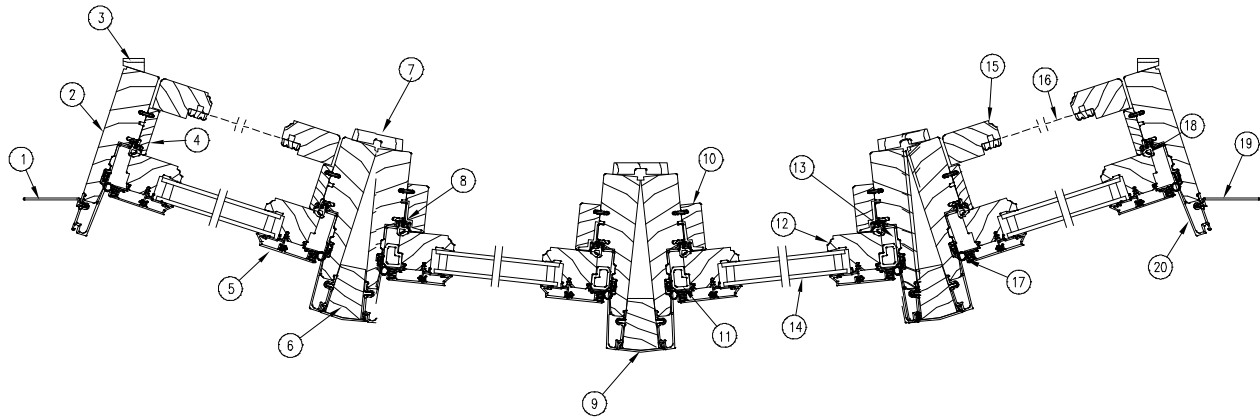

JAMB DETAIL

NOTE: Not to scale; specifications subject to change without notice.

- | | | |
|----------------------------|---------------------------|-------------------------|
| 1. Jamb Nailing Fin | 9. Clad Mull Cap | 17. Sash Weather Strip |
| 2. Jamb | 10. Side Stop | 18. Frame Weather Strip |
| 3. Return Jamb | 11. Stationary Sash Block | 19. Jamb Nailing Fin |
| 4. Side Stop | 12. Stile | 20. Jamb Cladding |
| 5. Stile Cladding | 13. Frame Thermal Break | |
| 6. Mull Block | 14. Insulated Glass | |
| 7. Interior Mull Trim | 15. Screen Frame | |
| 8. Stationary Sash Bracket | 16. Screen Mesh | |

WOOD ULTIMATE CASEMENT BOW OR BAY

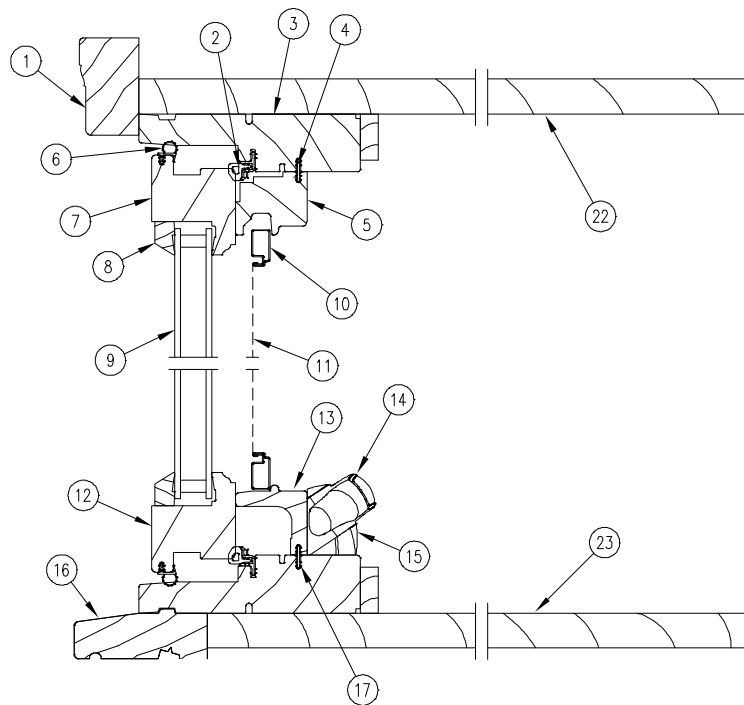

**HEAD JAMB
 & SILL DETAIL**

NOTE: Not to scale; specifications subject to change without notice.

- | | | |
|---------------------------------|-----------------------------|---------------|
| 1. Head Jamb Brick Mould Casing | 10. Screen Frame | 19. Jamb |
| 2. Frame Weather Strip | 11. Screen Mesh | 20. Jamb Stop |
| 3. Head Jamb | 12. Bottom Rail | 21. Stile |
| 4. Connecting Barb | 13. Hardware Cover | 22. Headboard |
| 5. Head Jamb Stop | 14. Folding Crank Handle | 23. Seatboard |
| 6. Sash Weather Strip | 15. Folding Crank Cover | |
| 7. Top Rail | 16. Subsill | |
| 8. Glazing Bead | 17. Sill | |
| 9. Insulated Glass | 18. Jamb Brick Mould Casing | |

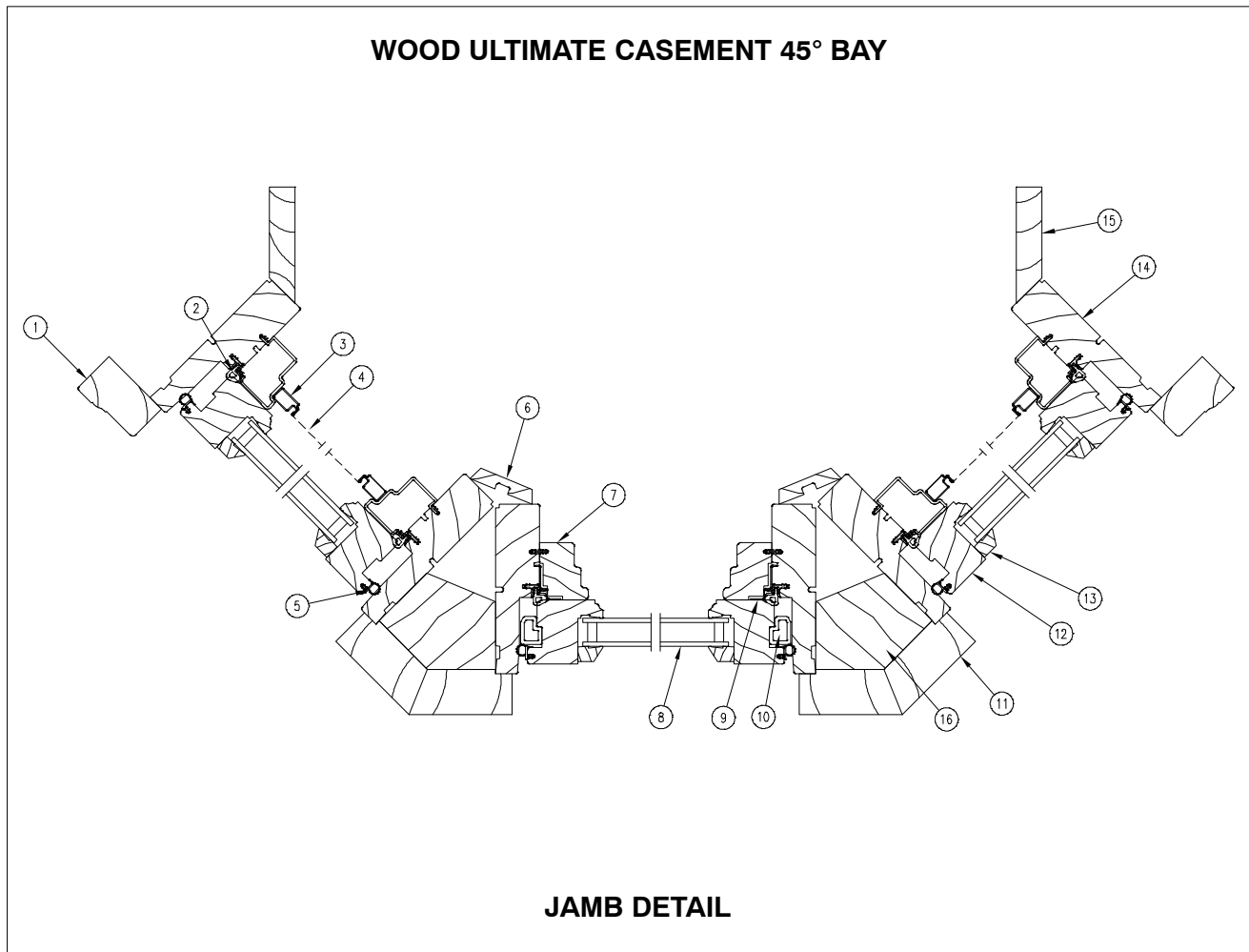

NOTE: Not to scale; specifications subject to change without notice.

- | | | |
|----------------------------|----------------------------|-----------------|
| 1. Side Brick Mould Casing | 8. Insulated Glass | 15. Return Jamb |
| 2. Frame Weather Strip | 9. Stationary Jamb Bracket | 16. Mull Block |
| 3. Screen Frame | 10. Stationary Sash Blocks | |
| 4. Screen Mesh | 11. Exterior Mull Casing | |
| 5. Sash Weather Strip | 12. Stile | |
| 6. Interior Mull Trim | 13. Glazing Bead | |
| 7. Side Stop | 14. Jamb | |

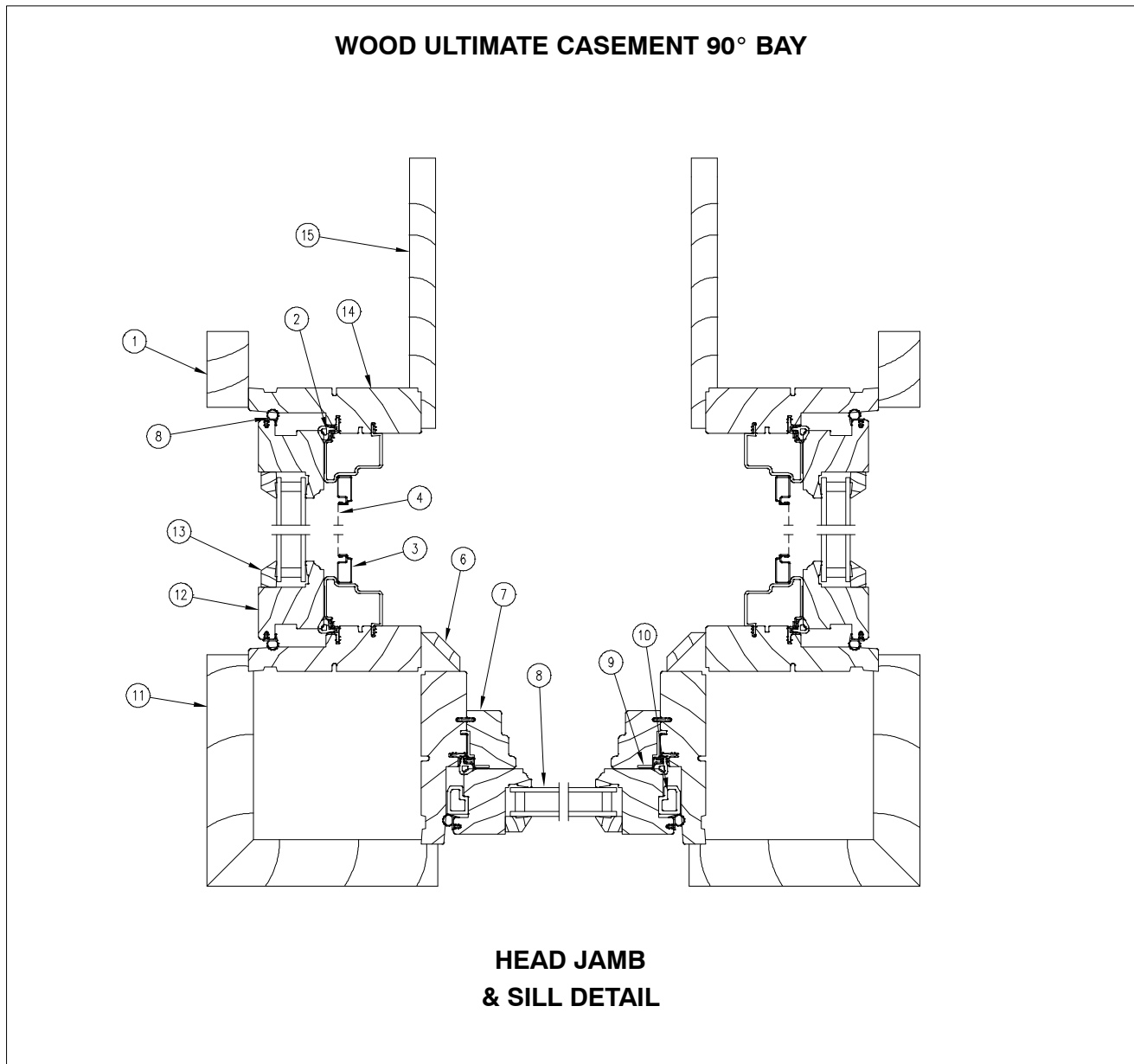

NOTE: Not to scale; specifications subject to change without notice.

- | | | |
|------------------------|----------------------------|--------------------------|
| 1. Side Flat Casing | 6. Interior Mull Trim | 11. Exterior Mull Casing |
| 2. Frame Weather Strip | 7. Side Stop | 12. Stile |
| 3. Screen Frame | 8. Insulated Glass | 13. Glazing Bead |
| 4. Screen Mesh | 9. Stationary Jamb Bracket | 14. Jamb |
| 5. Sash Weather Strip | 10. Stationary Sash Blocks | 15. Return Jamb |

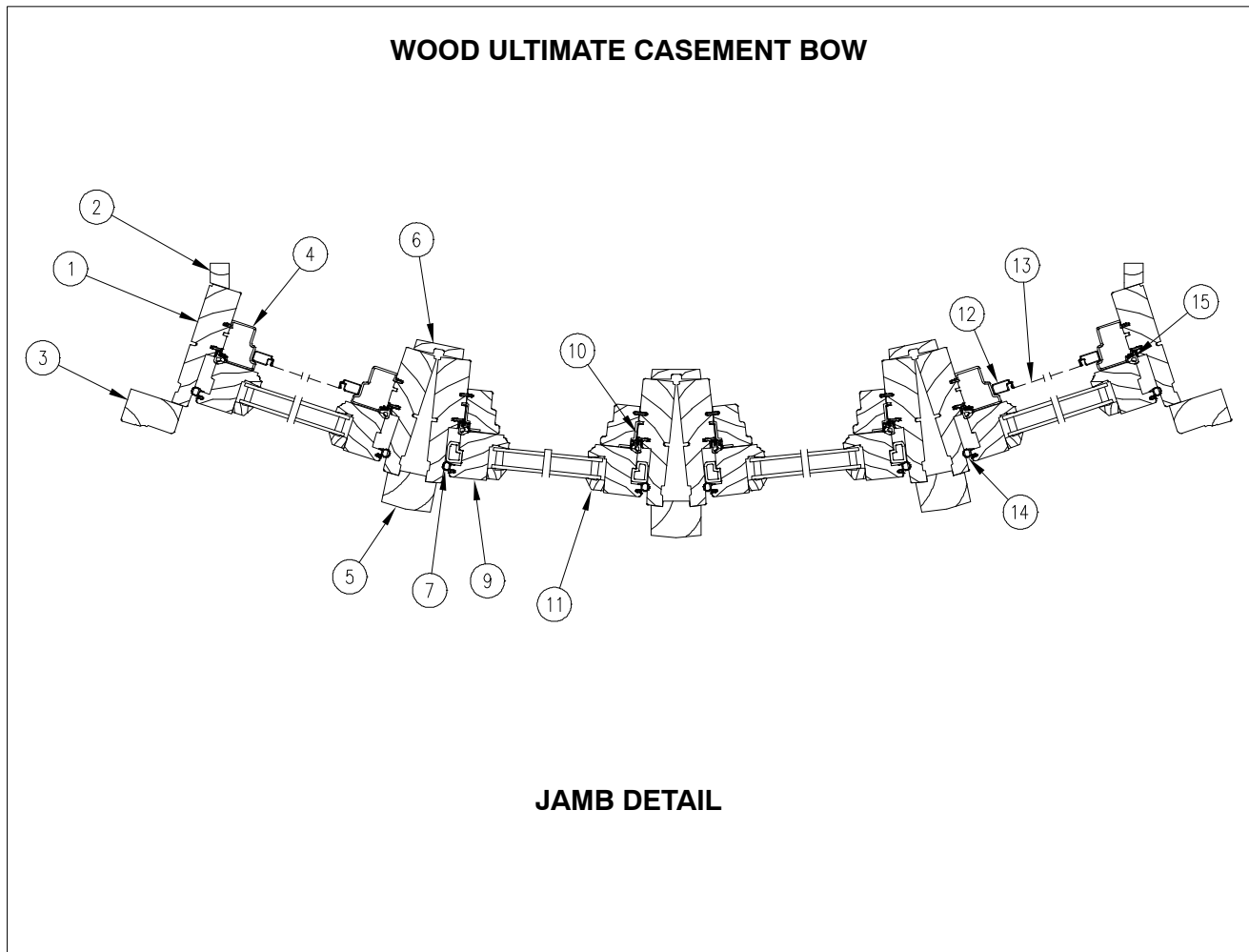

NOTE: Not to scale; specifications subject to change without notice.

- | | | |
|----------------------------|-----------------------------|-------------------------|
| 1. Jamb | 6. Interior Mull Trim | 11. Glazing Bead |
| 2. Return Jamb | 7. Stationary Sash Block | 12. Screen Frame |
| 3. Side Brick Mould Casing | 8. Insulated Glass | 13. Screen Mesh |
| 4. Side Stop | 9. Stile | 14. Sash Weather Strip |
| 5. Exterior Mull Casing | 10. Stationary Sash Bracket | 15. Frame Weather Strip |

PART IDENTIFICATION

WOOD ULTIMATE PUSH OUT CASEMENT BOW OR BAY

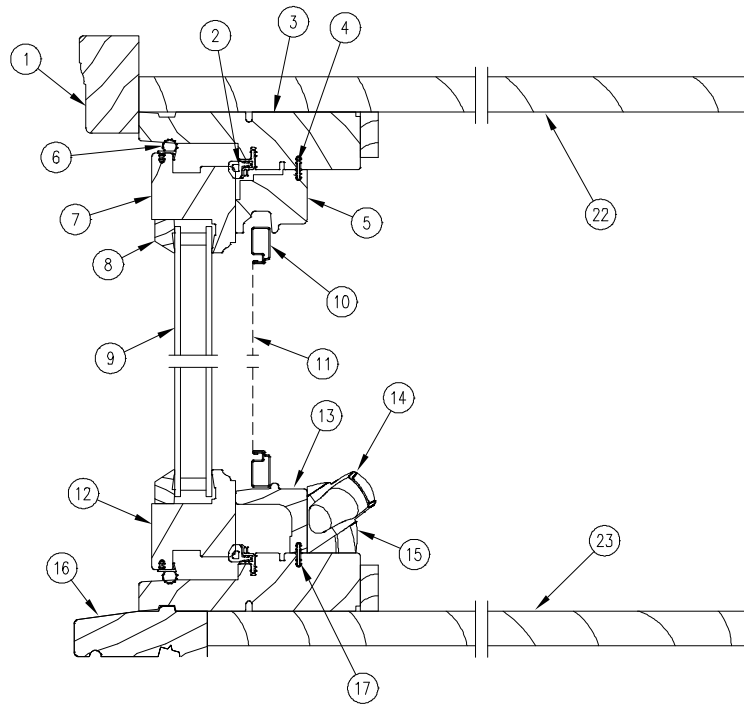

HEAD JAMB & SILL DETAIL

NOTE: Not to scale; specifications subject to change without notice.

- | | | |
|---------------------------------|-----------------------------|---------------|
| 1. Head Jamb Brick Mould Casing | 10. Screen Frame | 19. Jamb |
| 2. Frame Weather Strip | 11. Screen Mesh | 20. Jamb Stop |
| 3. Head Jamb | 12. Bottom Rail | 21. Stile |
| 4. Connecting Barb | 13. Hardware Cover | 22. Headboard |
| 5. Head Jamb Stop | 14. Folding Crank Handle | 23. Seatboard |
| 6. Sash Weather Strip | 15. Folding Crank Cover | |
| 7. Top Rail | 16. Subsill | |
| 8. Glazing Bead | 17. Sill | |
| 9. Insulated Glass | 18. Jamb Brick Mould Casing | |

WOOD ULTIMATE PUSH OUT CASEMENT 45° BAY

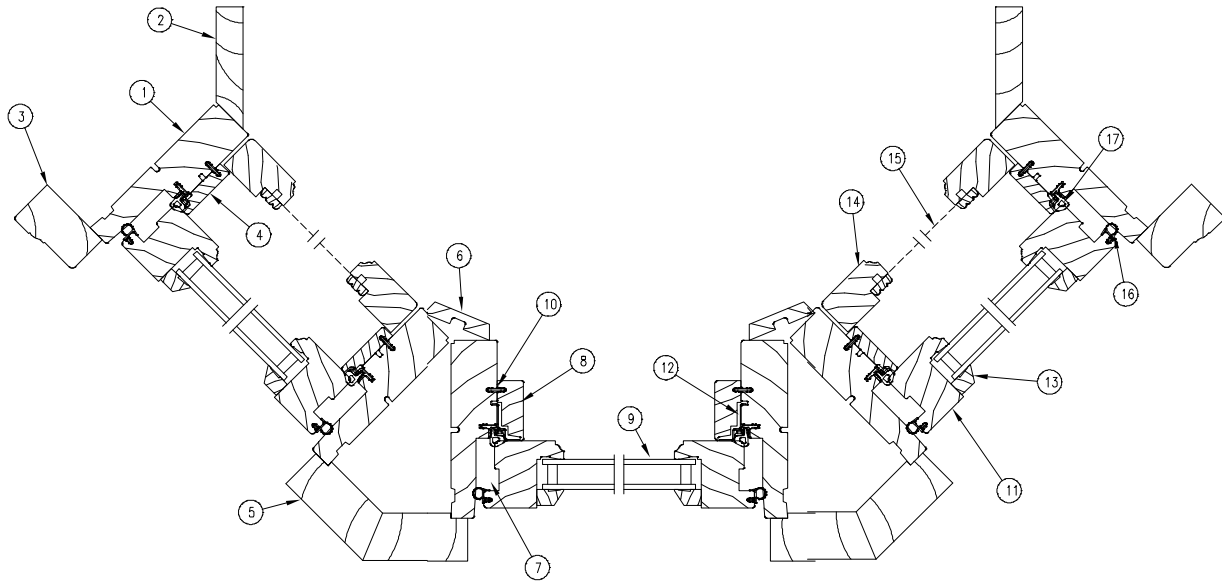

JAMB DETAIL

NOTE: Not to scale; specifications subject to change without notice.

- | | | |
|----------------------------|-----------------------------|-------------------------|
| 1. Jamb | 8. Stationary Side Stop | 15. Screen Mesh |
| 2. Return Jamb | 9. Insulated Glass | 16. Sash Weather Strip |
| 3. Side Brick Mould Casing | 10. Connecting Barb | 17. Frame Weather Strip |
| 4. Jamb Stop | 11. Stile | |
| 5. Exterior Mull Casing | 12. Stationary Sash Bracket | |
| 6. Interior Mull Trim | 13. Glazing Bead | |
| 7. Stationary Sash Block | 14. Wood Screen Frame | |

WOOD ULTIMATE PUSH OUT CASEMENT 90° BAY

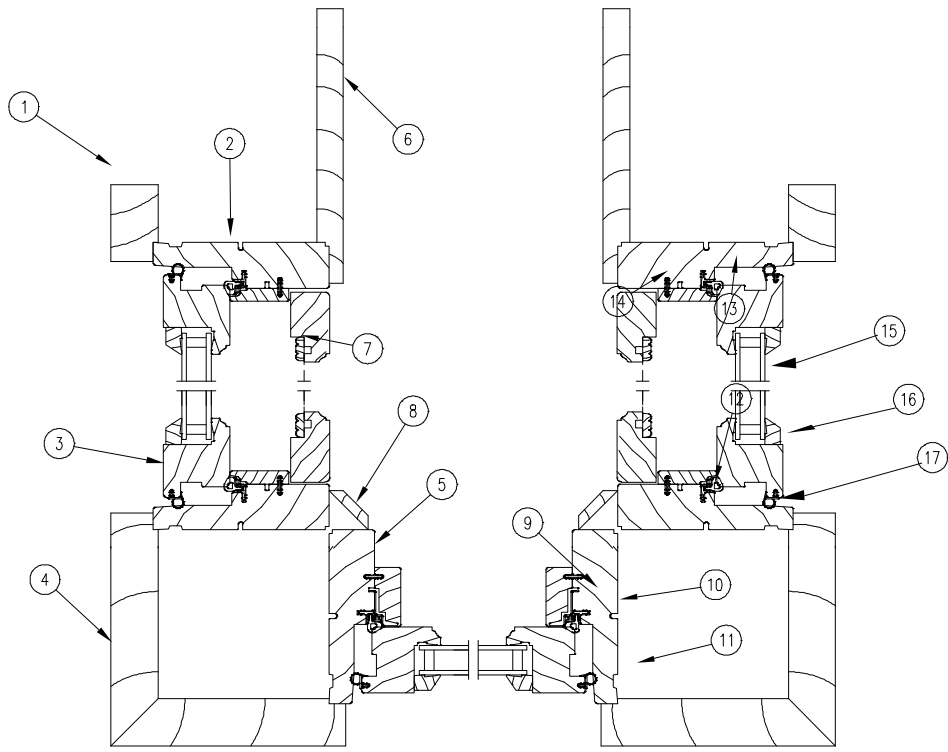

**HEAD JAMB
 & SILL DETAIL**

NOTE: Not to scale; specifications subject to change without notice.

- | | | |
|-------------------------|-----------------------------|-----------------------|
| 1. Side Flat Casing | 8. Interior Mull Trim | 15. Insulated Glass |
| 2. Frame Weather Strip | 9. Stationary Side Stop | 16. Glazing Bead |
| 3. Stile | 10. Stationary Jamb Bracket | 17. Sash Weatherstrip |
| 4. Exterior Mull Casing | 11. Stationary Sash Bracket | |
| 5. Jamb | 12. Connecting Barb | |
| 6. Return Jamb | 13. Jamb Stop | |
| 7. Screen Mesh | 14. Wood Screen Frame | |

WOOD ULTIMATE PUSH OUT CASEMENT BOW

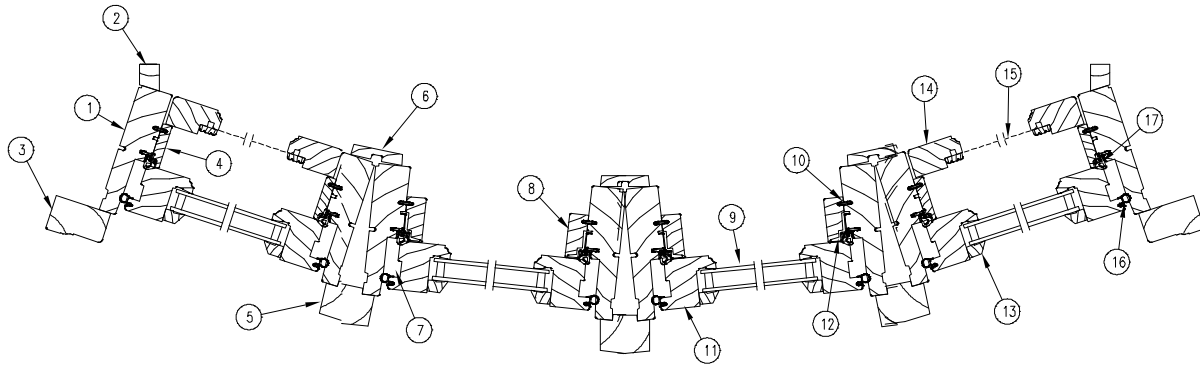

JAMB DETAIL

NOTE: Not to scale; specifications subject to change without notice.

- | | | |
|----------------------------|-----------------------------|-------------------------|
| 1. Jamb | 8. Stationary Side Stop | 15. Screen Mesh |
| 2. Return Jamb | 9. Insulated Glass | 16. Sash Weather Strip |
| 3. Side Brick Mould Casing | 10. Connecting Barb | 17. Frame Weather Strip |
| 4. Jamb Stop | 11. Stile | |
| 5. Exterior Mull Casing | 12. Stationary Sash Bracket | |
| 6. Interior Mull Trim | 13. Glazing Bead | |
| 7. Stationary Sash Block | 14. Wood Screen Frame | |

WOOD ULTIMATE DOUBLE HUNG BAY

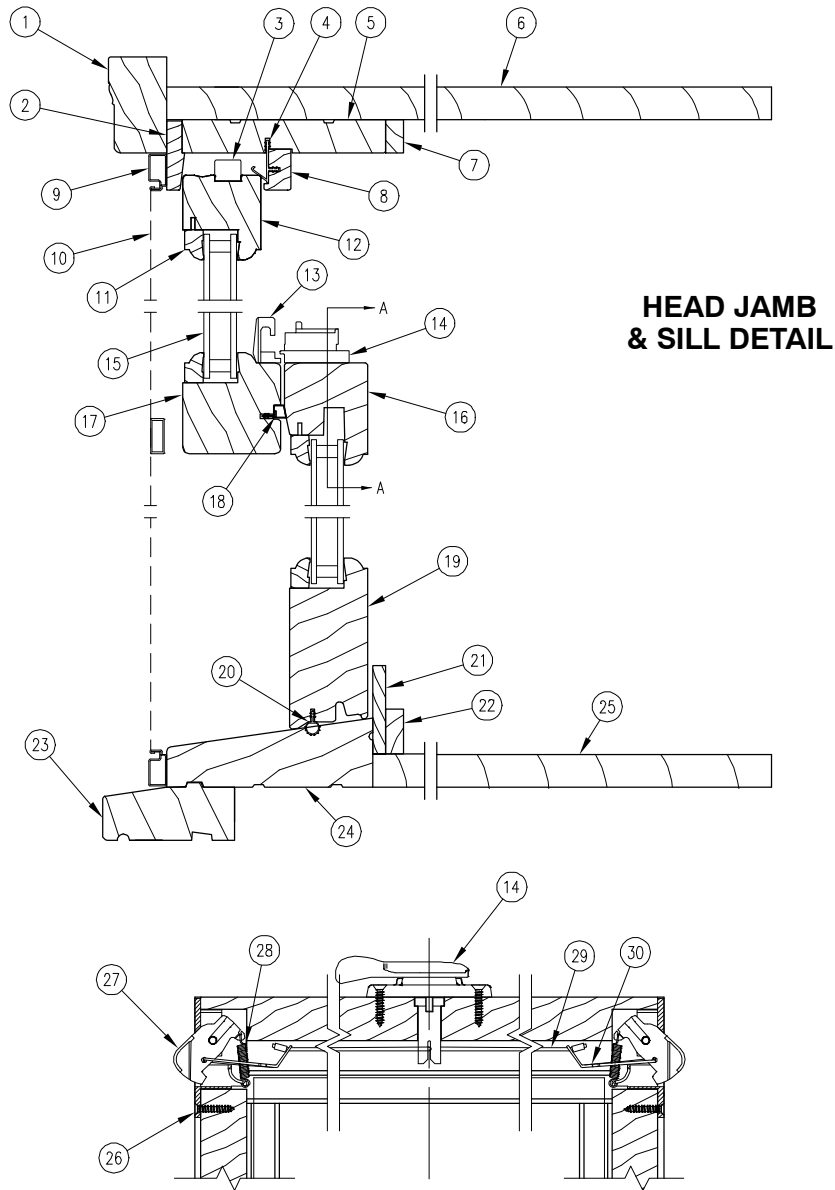

**HEAD JAMB
 & SILL DETAIL**

SECTION A-A

NOTE: Not to scale; specifications subject to change without notice.

- | | | |
|-------------------------------|-------------------------------|--------------------------|
| 1. Top Brick Mould Casing | 11. Glazing Bead | 21. Sill Liner |
| 2. Top Blind Stop | 12. Top Rail | 22. Bottom Interior Trim |
| 3. Tilt Latch | 13. Sash Keeper | 23. Subsill |
| 4. Parting Stop Weather Strip | 14. Sash Lock | 24. Sill |
| 5. Head Jamb | 15. Insulated Glass | 25. Seat Board |
| 6. Head Board | 16. Bottom Check Rail | 26. End Plate |
| 7. Top Interior Trim | 17. Top Check Rail | 27. Locking Blade |
| 8. Parting Stop | 18. Check Rail Weather Strip | 28. Extension Spring |
| 9. Screen Frame | 19. Bottom Rail | 29. Operation Cord |
| 10. Screen Mesh | 20. Bottom Rail Weather Strip | 30. Pull Yoke |

WOOD ULTIMATE DOUBLE HUNG BAY

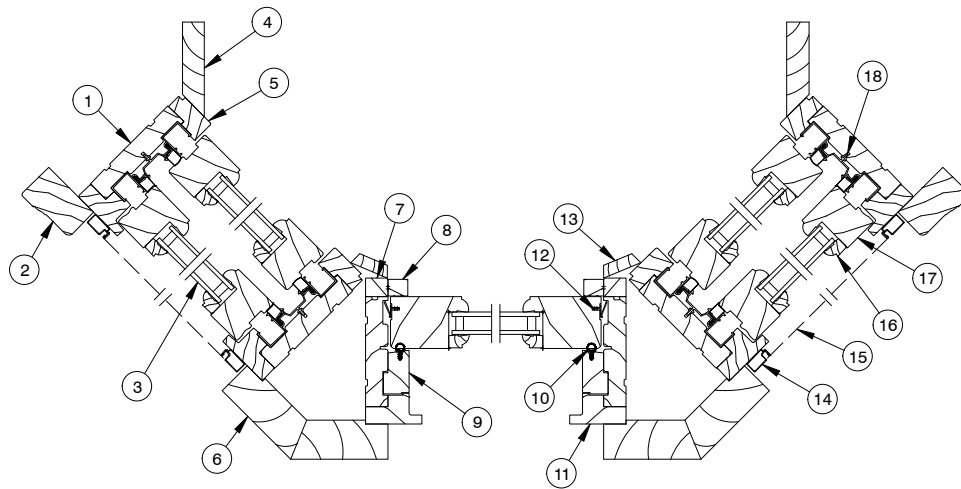

JAMB DETAIL

NOTE: Not to scale; specifications subject to change without notice.

- | | |
|-----------------------------------|------------------------|
| 1. Jamb | 11. Exterior Blindstop |
| 2. Side Brick Mould Casing | 12. Vinyl Retainer |
| 3. Insulated Glass | 13. Interior Mull Trim |
| 4. Return Jamb | 14. Screen Frame |
| 5. Jamb Liner | 15. Screen Mesh |
| 6. Exterior Mull Casing | 16. Glazing Bead |
| 7. Picture Jamb Liner | 17. Stile |
| 8. Interior Stop | 18. Vinyl Jamb Carrier |
| 9. Exterior Filler | |
| 10. Exterior Filler Weather Strip | |

CLAD ULTIMATE DOUBLE HUNG BAY

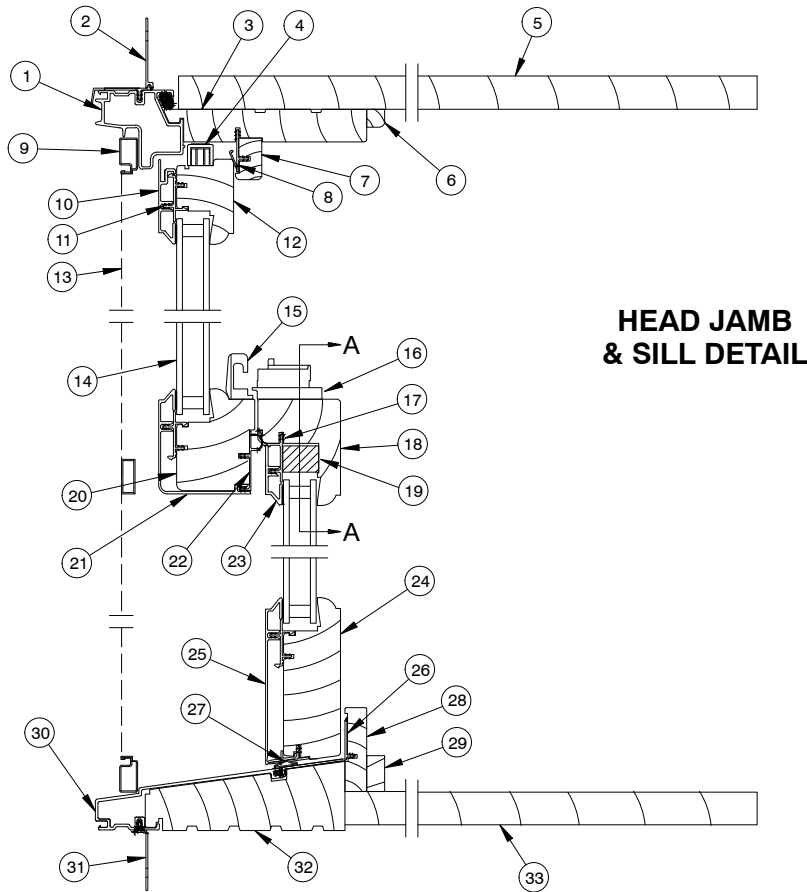

**HEAD JAMB
 & SILL DETAIL**

SECTION A-A

NOTE: Not to scale; specifications subject to change without notice.

- | | | | |
|-----------------------------------|---------------------------------|-------------------------------|----------------------|
| 1. Head Jamb Cladding | 13. Screen Mesh | 23. Bottom Checkrail Cladding | 35. Locking Blade |
| 2. Head Jamb Nailing Fin/Drip Cap | 14. Insulated Glass | 24. Bottom Rail | 36. Extension Spring |
| 3. Head Jamb | 15. Sash Keeper | 25. Bottom Rail Cladding | 37. Operation Cord |
| 4. Tilt Latch | 16. Sash Lock | 26. Sill Cover | 38. Pull Yolk |
| 5. Head Board | 17. Bottom Checkrail | 27. Bottom Rail Weather Strip | |
| 6. Top Interior Trim | 18. Bottom Checkrail | 28. Sill Liner | |
| 7. Parting Stop | 19. Bottom Checkrail | 29. Bottom Interior Trim | |
| 8. Parting Stop Weather Strip | 20. Top Checkrail | 30. Sill Cladding | |
| 9. Screen Frame | 21. Top Checkrail Cladding | 31. Sill Nailing Fin | |
| 10. Top Rail Cladding | 22. Top Checkrail Weather Strip | 32. Sill | |
| 11. Sash Cladding Clip | | 33. Seat Board | |
| 12. Top Rail | | 34. End Plate | |

CLAD ULTIMATE DOUBLE HUNG BAY

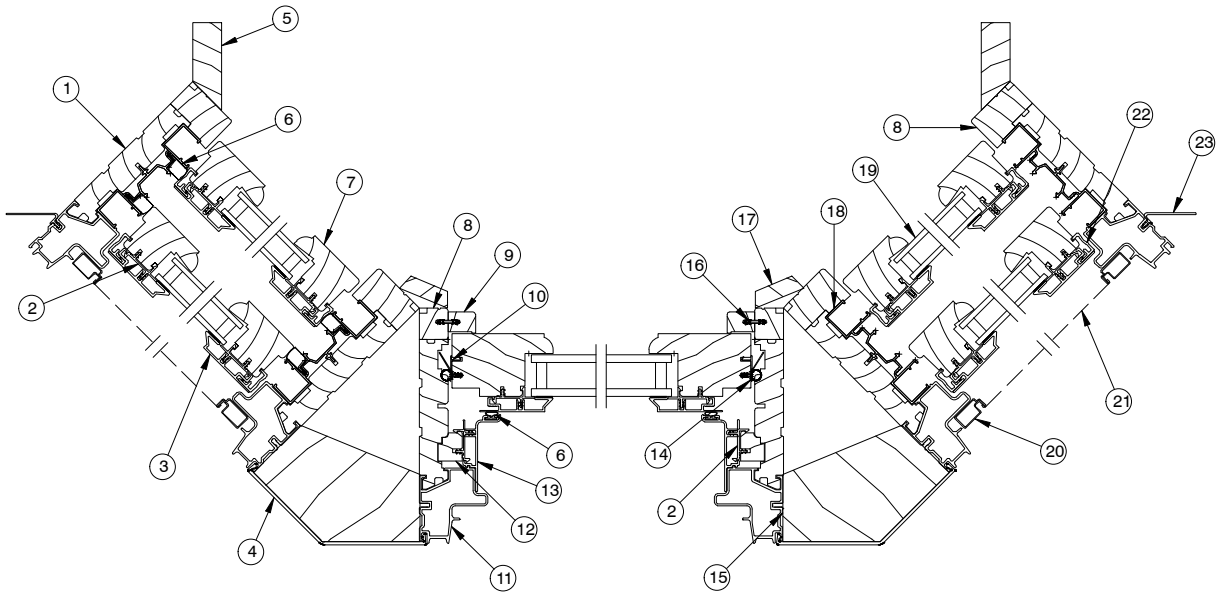

JAMB DETAIL

NOTE: Not to scale; specifications subject to change without notice.

- | | |
|----------------------------|--------------------------|
| 1. Jamb | 13. Jamb Filler Cladding |
| 2. Sash Cladding Connector | 14. Sash Weather Strip |
| 3. Stile Cladding | 15. Mull Block |
| 4. Clad Mull Cap | 16. Connecting Barb |
| 5. Return Jamb | 17. Interior Mull Trim |
| 6. Frame Weather Strip | 18. Vinyl Jamb Carrier |
| 7. Stile | 19. Insulated Glass |
| 8. Jamb Liner | 20. Screen Frame |
| 9. Interior Sash Stop | 21. Screen Mesh |
| 10. Vinyl Retainer | 22. Contact Strip |
| 11. Jamb Cladding | 23. Jamb Nailing Fin |
| 12. Jamb Block | |

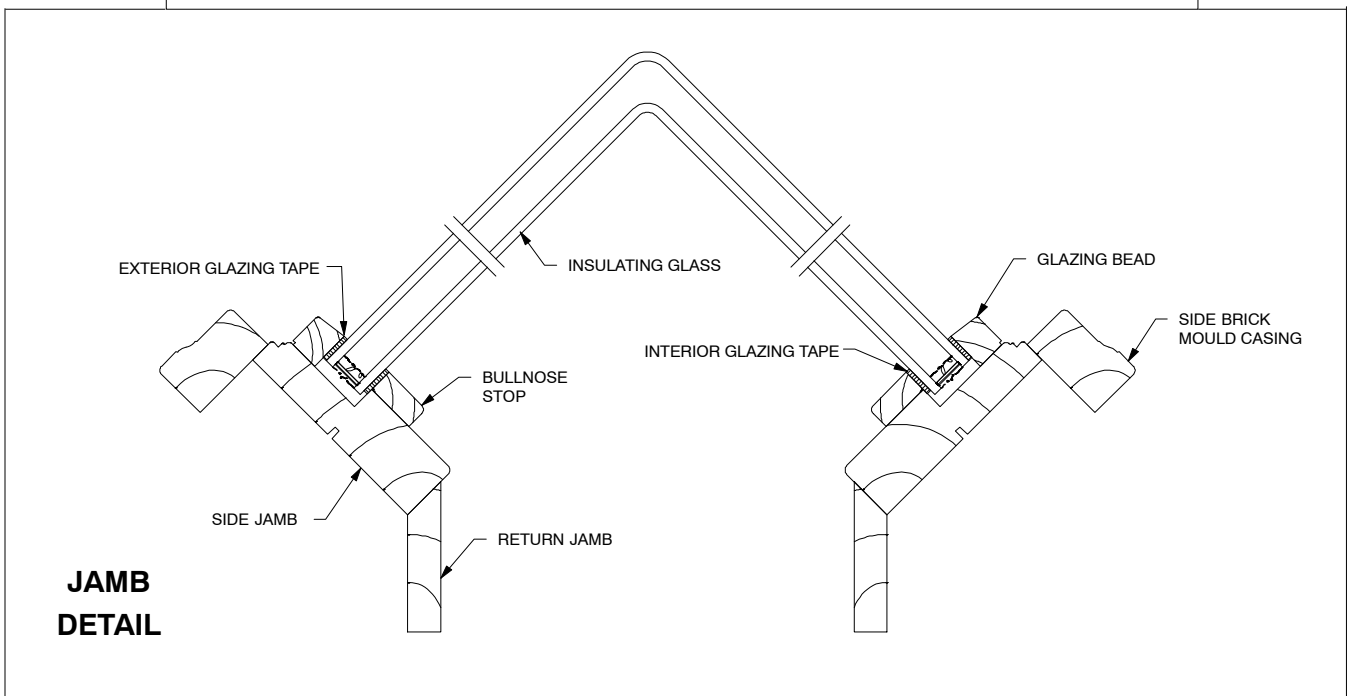
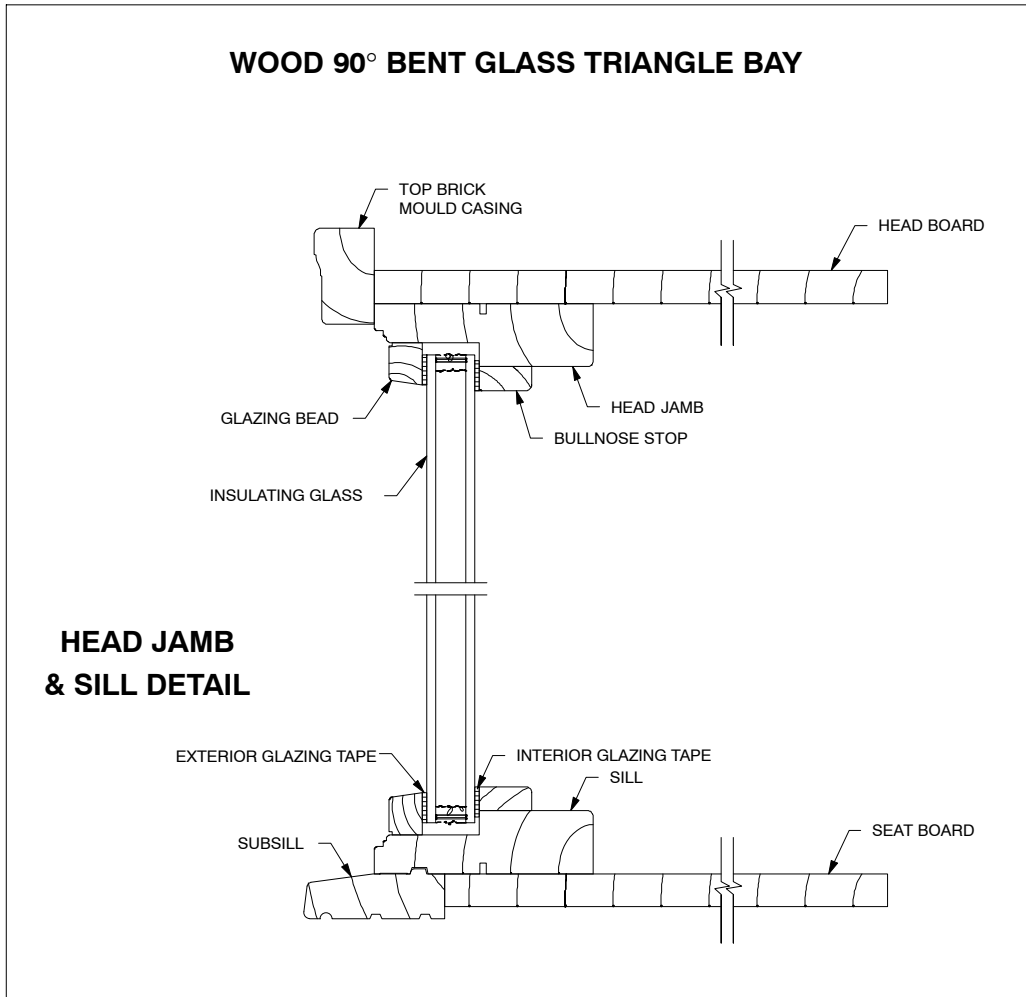

NOTE: Not to scale; specifications subject to change without notice.

REPLACEMENT PARTS FOR BOWS AND BAYS

Wood and Clad Ultimate Double Hung, Ultimate Casement and Casemaster Bows or Bays utilize many of the parts found in their respective sections of the Parts Manual. Please refer to these for additional information.

REPLACEMENT ALUMINUM BOW AND BAY PARTS

When ordering replacement aluminum parts specify:

1. profile number;
2. finish.

NOTE: Most replacement aluminum parts are supplied in 168" (4267) or 150" (3810) lengths. See Misc Mouldings Chapter for part numbers.

	CLAD
Mull Cap – Bow	A124
Mull Cap – 30° Bays	A122
Mull Cap – 45° Bays	A123
Corner Cover – 90° Bays	A127
3" Frame Expander	A109
2" Mullion Expander	A108

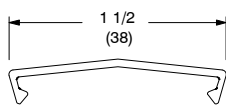

A124 – Mull Cap Bow

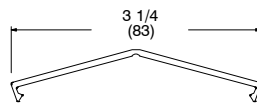

A122 – Mull Cap 30° Bays

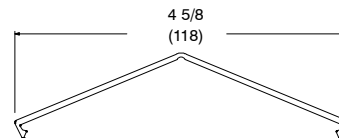

A123 – Mull Cap 45° Bays

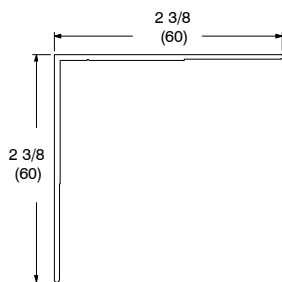

A127 – Corner Cover 90° Bays

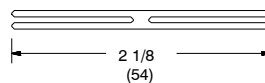

A108 – 2" Mullion Expander

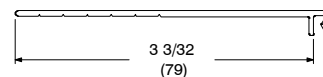

A109 – 3" Frame Expander

CURRENT REPLACEMENT BOW AND BAY WOOD PARTS

For Clad and Wood Ultimate Double Hung (UDH), Ultimate Casement (UCA) and Casemaster (CM)

	CLAD	WOOD
Interior Trim – UCA/CM Bow/Bay (top or bottom) UDH Bay (bottom)	W6110	W6110
Interior Trim – UDH Bay (top)	W1181	W1181
Interior Mull Trim – UCA/CM Bow & Clad UDH	W1189	W1189
Interior Mull Trim – 30 degree UCA/CM Bay	W1185	W1185
Interior Mull Trim – 45 degree UCA/CM Bay	W1187	W1187
Interior Mull Trim – 60 degree UCA/CM Bay	---	W1176
Interior Mull Trim – 90 degree UCA/CM Bay	W1179	W1179
Interior Mull Trim – 30 degree UDH Bay	W1182	W1182
Interior Mull Trim – 45 degree UDH Bay	W1184	W1184
Interior Mull Trim – 60 degree UDH Bay	---	W1177
Interior Mull Trim – 90 degree UDH Bay	W1178	W1178
Exterior Mull Casing – UCA/CM Bow	---	W1132
Exterior Mull Casing – 30° UCA/CM Bay	---	W1102
Exterior Mull Casing – 45° UCA/CM Bay	---	W1104
Exterior Mull Casing – 60° UCA/CM Bay	---	W1106
Exterior Mull Casing – 90° UCA/CM Bay	---	W1108
Exterior Mull Casing – 30° UDH Bay	---	W1110
Exterior Mull Casing – 45° UDH Bay	---	W1112
Exterior Mull Casing – 60° UDH Bay	---	W1114
Exterior Mull Casing – 90° UDH Bay	---	W1116
Mull Block – Clad UCA/CM Bow	W7318	---
Mull Block – 30° Clad Bays	W7308	---
Mull Block – 45° Clad Bays	W7310	---

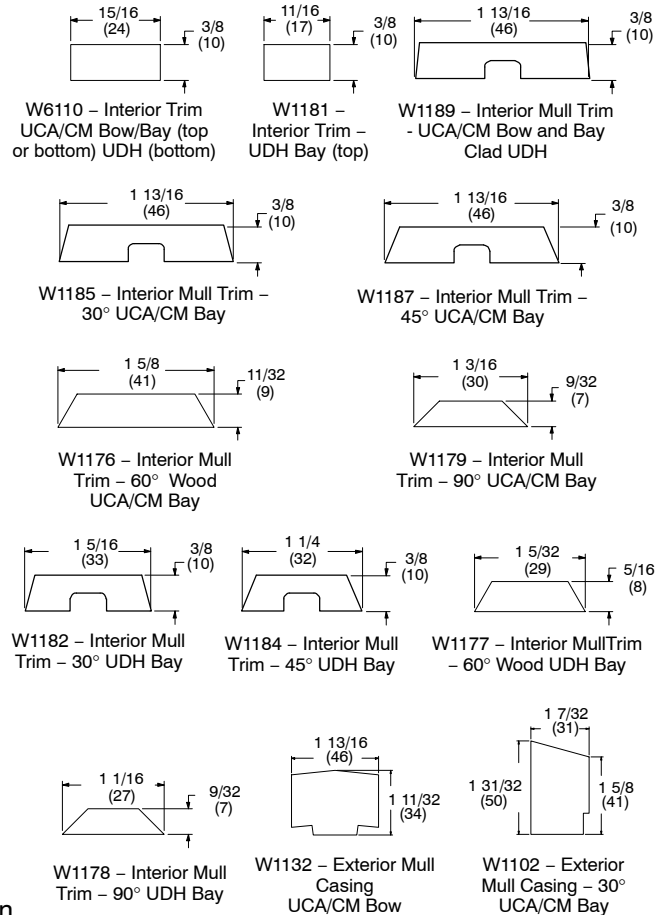

NOTE: Some interior mull trims notched for cable as shown.

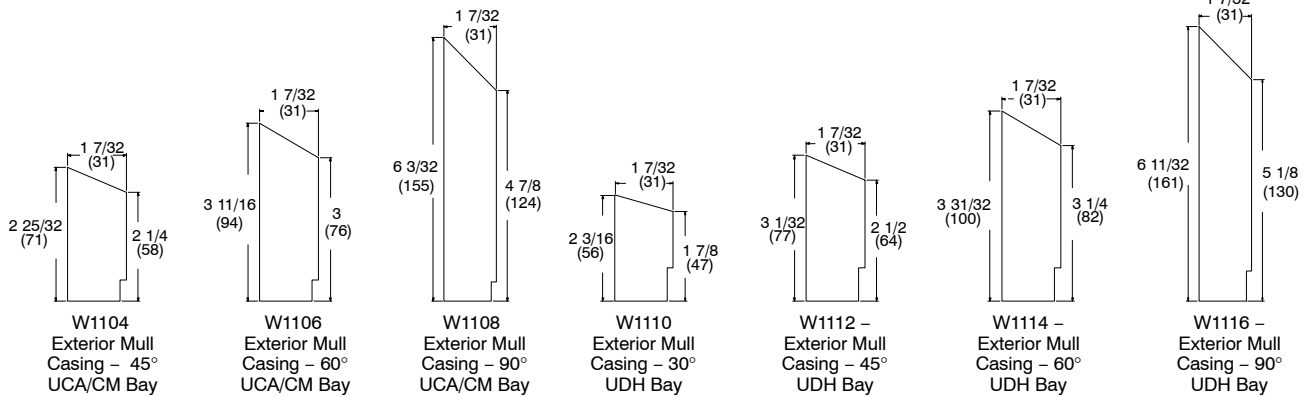

TO ORDER REPLACEMENT WOOD PARTS

When ordering replacement wood parts specify:

1. profile number;
2. size – (call number or length);
3. finish.

NOTE: Wood bay exterior mull casing is shipped as an assembled pair.

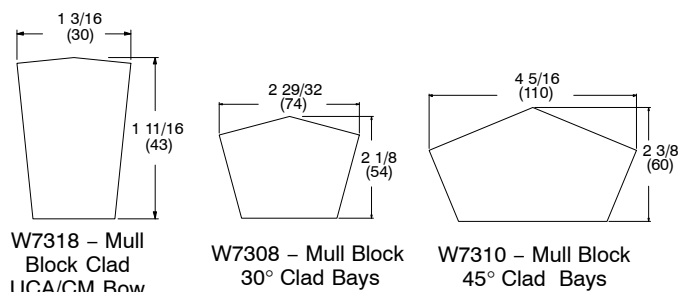

TO ORDER REPLACEMENT HEAD OR SEAT BOARDS

NOTE: REPLACEMENT HEAD AND SEAT BOARD MATERIAL IS RECTANGULAR IN SHAPE.

For assistance in determining size required contact Marvin Technical Support with the unit type and finish (bow/bay, clad/wood), angle (30/45/90, etc), unit size, projection and jamb depth.

PLYWOOD CORE/NON FINGER-JOINTED PINE VENEER HEAD AND SEAT BOARD AVAILABILITY CHART

NOTE: Part Number is for one board only – must order two if needed for head and seat board.

Stock Size	Part Number
16 x 72	18218202
16 x 96	18218204
16 x 108	18218206
18 x 72	18218402
18 x 84	18218404
18 x 108	18218406
20 x 84	18218602
20 x 96	18218604
20 x 108	18218606
20 x 120	18218608
22 x 72	18218702
22 x 84	18218704
22 x 96	18218706
22 x 108	18218708
22 x 132	18218710
24 x 72	18218902
24 x 84	18218904
24 x 96	18218906
24 x 120	18218910
24 x 132	18218912
24 x 144	18218914
26 x 84	18219002
26 x 108	18219004
27 x 120	18219104
28 x 96	18219202
28 x 108	18219204
30 x 108	18219302
30 x 132	18219304
30 x 144	18219306
42 x 168	18219510

ILLUSTRATION NOT TO SCALE	DESCRIPTION	OPER./ COLOR	PART NO.
	<p>Cable Support System – Field Installation Kit</p> <p><i>Includes:</i></p> <ul style="list-style-type: none"> 2 – Cable clamps 1/4" x 3 1/8" (zinc die-cast) (a) 4 – Heavy-shank mounting screws #12 x 3" (b) 1 – #3 Phillips drive bit (c) 2 – Adjustment hole plugs (d) 2 – Cable assemblies – 9' or 12' x 1/8" diameter (e) 2 – Fender washers – 0.25" x 0.265" x 0.06" (f) 2 – T-nuts, 3 prong 5/16" – 18" x 3/8" (g) 4 – Heavy hex nuts 1/4" – 28" (h) 2 – Installation Plates (10500560) (UDH units only) (i) 4 – #7 x 7/8" screws (11800778) (UDH units only) (j) 	<p>9' CM 12' CM</p> <p>9' UDH 12' UDH</p>	<p>11850134 11850135</p> <p>11850136 11850137</p>
	<p>Bow/Bay Installation Plate Package</p> <p><i>(UDH only)</i></p> <p><i>Includes:</i></p> <ul style="list-style-type: none"> 2 – Installation plates (10500560) (i) 4 – #7 x 7/8" screws (11800778) (j) 		<p>11850133</p>

OBSOLETE SUN BAY PARTS

When ordering obsolete Sun Bay parts specify:

1. part number;
2. description.

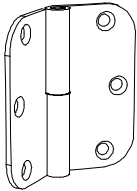
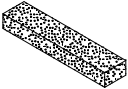
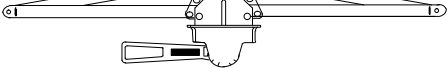
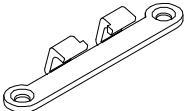
ILLUSTRATION NOT TO SCALE	DESCRIPTION	OPER./ COLOR	PART NO.
	<p>Butt Hinge, Stainless Steel</p> <p><i>Includes:</i></p> <p>1 – SS hinge</p> <p>3 – SS #7x7/8" Phillips head wood screws (11800777)</p> <p>3 – 8-32x5/8" Phillips head machine screws (05080233) and T-nuts (05080234)</p> <p>NOTE: Handing on butt hinges are viewed from the interior. Example – if your Sun Bay sash is on the right hand side of the unit, it requires a right hand hinge.</p>	LH RH	10929102 10929103
	<p>Foam Pad, Butt Hinge</p>		No longer available
	<p>Lever Operator</p> <p><i>Includes:</i></p> <p>1 – Dual pull lever operator</p> <p>4 – #8x1" Phillips flathead wood screws</p> <p>NOTE: Handing on operators are viewed from the interior. Example – if your Sun Bay sash is on the right hand side of the unit, it requires right hand hardware.</p>	LH BZ LH WH LH BS RH BZ RH WH RH BS	No longer available No longer available
	<p>Sash Hook</p> <p><i>Includes:</i></p> <p>1 – Sash hook</p> <p>2 – #7HD – #8x1" Phillips flathead wood screws (11800773)</p>		10820008

OBSELETE REPLACEMENT WOOD PARTS

Glazing Stop – Head Jamb	W7054
Glazing Stop – Top Mull	W7056
Glazing Stop – Bottom Mull	W7058
Glazing Stop – Sloped Top (1" IG)	W4094
Glazing Stop – Front (3/16" Single Glaze)	W4098
Screen Channel	W7028
Hardware Cover	W7064
Hardware Cover Filler	W7041
Mull Casing (top and front)	W6152

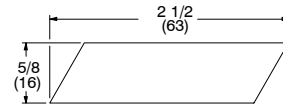

W7054 – Glazing Stop – Head Jamb

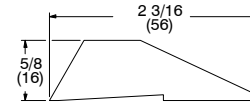

W7056 – Glazing Stop – Top Mull

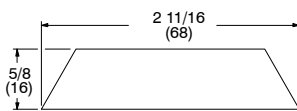

W7058 – Glazing Stop – Bottom Mull

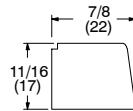

W4094 – Glazing Stop – Sloped Top (1" IG)

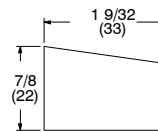

W4098 – Glazing Stop – Front (3/16" Single Glaze)

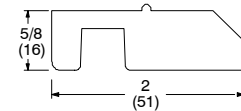

W7028 – Screen Channel

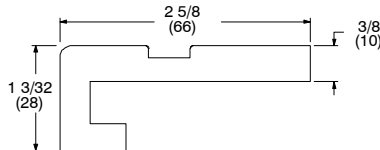

W7064 – Hardware Cover

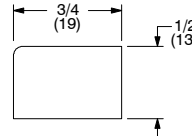

W7041 – Hardware Cover Filler

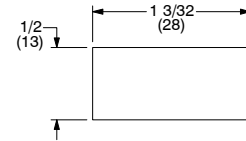

W6152 – Mull Casing (top and front)

When ordering replacement wood parts specify:

1. profile number;
2. call number or rough opening;
3. length;
4. finish.

OBSELETE SASH REPLACEMENT

Sun Bays featured a direct glazed front and sloped top. Sun Bays sides were in-sash and are replaceable based on standard size in the chart below.

Call Number	OM of Sash
CN 1640	14 5/16" width x 28 7/16" (short side) x 36 11/16" (long side)

When ordering replacement Sun Bays sash specify:

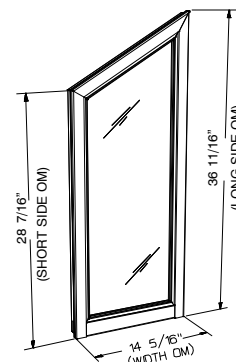

1. call number;
2. glazing;
3. finish;
4. handling (left or right as viewed from the exterior).



OBSOLETE SUN BAY WEATHER STRIP

When ordering replacement weather strip specify:

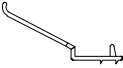
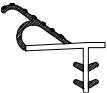
1. quantity;
2. color;
3. part number;
4. description.

ILLUSTRATION <i>NOT TO SCALE</i>	DESCRIPTION	LENGTH	PART NUMBER
	Frame Weather Strip V101 Used between 1983 – 1992 Color: White		No longer available Replaced with: --- V673 – Top Casing V191 – Sash V192 – Head Jamb, Jamb and Sill
	Top Casing Weather Strip V673 Used between 1992 – 1994 Color: Beige Replacement for V101.	84" (2134) 144" (3658)	15899984 15899999
	Sash Weather Strip V191 Used between 1992 – 1994 Color: Beige	150" (3810)	No longer available
	Head Jamb, Jamb and Sill Weather Strip V192 Used between 1992 – 1994 Color: Beige	84" (2134)	15900058

ORDERING REPLACEMENT SCREENS FOR SUN BAYS

Sun Bay side vent screens are available with aluminum surround and charcoal colored fiberglass 18 x 16 screen mesh. Aluminum mesh is available as an option in black, charcoal, bright aluminum or bright bronze. Surrounds are available in bronze or white.

When ordering replacement screen specify:

1. handing (left or right as viewed from the exterior)
2. color;
3. mesh type (if other than standard).

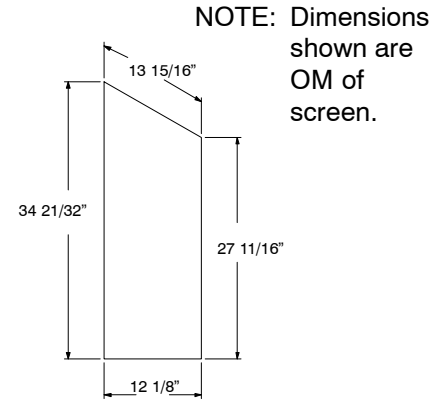

**CN1640
SIDE VENT
SCREEN**

OBSOLETE SUN BAY SCREEN PARTS

ILLUSTRATION <i>NOT TO SCALE</i>	DESCRIPTION	OPER./COLO R	PART NO.
	Leaf Spring M0104		11868835
	Finger Pull, Clear V254 Replaces colored finger pull		11860350

ORDERING REPLACEMENT ENERGY PANELS FOR SUN BAYS

If you are replacing an existing energy panel, determine the outside measurement of the existing energy panel. Energy panels are available for Sun Bay side vents or front stationary panel with bronze or stone white, surrounds.

When ordering energy panels specify:

1. size;
 - a. front EP – if there is no existing EP from which to obtain the OM (of the front panel), determine the size of the panel based on the chart below.
 - b. side panel – specify handing (left or right as viewed from the exterior).
2. color of surround;
3. glass type.

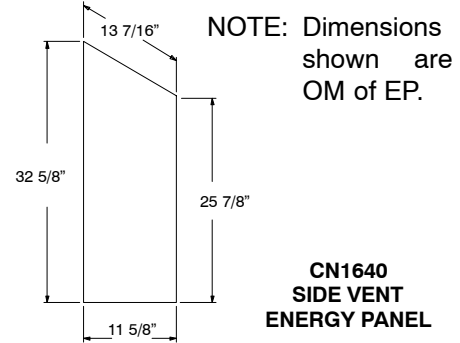

Sun Bay Front Stationary Energy Panel			
WIDTH		HEIGHT	
SIZE	OM WIDTH	SIZE	OM HEIGHT
WSBAY 40	40 13/16"	WSBAY	27 5/16"
WSBAY 48	48 13/16"		
WSBAY 56	56 13/16"		
WSBAY 64	64 13/16"		
WSBAY 72	72 13/16"		

OBSOLETE SUN BAY ENERGY PANEL PARTS

Energy panels are attached with turn buttons. Turn button styles may vary depending on current stock. You will receive the most current style in the color of your choice. (Obsolete black turn buttons will be replaced by brown.)

When ordering energy panels parts specify:

1. quantity;
2. description;
3. color;
4. part number.