

Wood Ultimate In-Sash Casement Polygon

Unit Features.....	1
Minimum and Maximum Guidelines	2
Minimum and Maximum Guidelines and Certified Sizes: IZ3 / Stationary.....	3
Measurement Conversions and Egress Openings.....	4
Slope to Angle and Angle to Pitch Conversions.....	5
Section Details: Stationary Full Frame	6
Section Details: Stationary IZ3 - 3/4" (19) and 1" (25) IG.....	7
Section Details: Stationary Replacement Frame.....	8
Section Details: Stationary in DH Replacement Frame.....	9
Section Details: Operable Full Frame	10
Section Details: Operable Replacement Frame	11
Section Details: Operable Replacement Frame in Double Hung Frame.....	12
Section Details: Stationary In-Sash Casement Polygon Mullion Options.....	13
Section Details: Operable In-Sash Casement Polygon Mullion Options	14
Configuration Limits.....	15
Polygon Shape Reference	16
Field Measurement.....	17

Wood Ultimate In-Sash Casement Polygon

Unit Features

Wood Ultimate Casement Polygon: WUCAPOLY

Wood Ultimate Replacement Casement Polygon: WURCAPOLY

Frame:

- Minimum frame angle 15°, minimum short leg of Rough Opening 6"

WUCAPOLY Hardware:

- Folding handles are standard.
 - Color: Satin Taupe is standard with optional colors White, Bronze, Satin Chrome, Satin Nickel, Oil Rubbed Bronze, Brass, Antique Brass.
- Locks used are a concealed multi-point sequential system.
 - OM spring line heights over 26 1/8" (664) to 53 1/8" (1349) will have a 2 point locking system.
 - OM spring line heights greater than 53 1/8" (1349) will have a 3 point locking system.
- Operable polygons have a single arm operator that includes a crank hardware system that allows the window to open to a full 90 degrees with a minimal reduction of egress net clear opening. All steel is covered with an E-Gard™ protection coat and the standard track is stainless steel. Operation force at handle is 5 lbs. or less.
- Units greater than 71 1/8" (1807) in height will require the use of a sash limiter, which is located on the operator track.
- Stainless Steel packages are available for coastal application.
- Replacement frame does not allow for the wash-mode feature.

Optional Glass for Full Frame Units:

- 1" Tripane Low E1 outer piece and Low E1 Argon inner piece
- 1" Tripane Low E1 outer piece and Low E1 Krypton-Argon inner piece
- 1" Tripane Low E2 outer piece and Low E2 Argon inner piece
- 1" Tripane Low E2 outer piece and Low E2 Krypton-Argon inner piece
- 1" Tripane Low E3 outer piece and Low E1 Argon inner piece
- 1" Tripane Low E3 outer piece and Low E1 Krypton-Argon inner piece

Wood Ultimate In-Sash Casement Polygon

Minimum and Maximum Guidelines

Minimum and Maximum Non - Certified - Full and Replacement Wood Ultimate Casement Polygon - Operable											
Unit Type		Min Width		Min Height		Max Width		Max Height		Min Springline	
		in	mm	in	mm	in	mm	in	mm	in	mm
Insulating Glass 3/4", SG or 1" (Replacement N/A 1")	P4-0, P4-5/6	16	(406)	27 1/16	(687)	36	(914)	97 1/16	(2465)	27 1/16	(687)
						40	(1016)	97 1/16	(2465)	27 1/16	(687)
	P5-1, P5-5/6, P5-13/14	16	(406)	27 1/16	(687)	36	(914)	97 1/16	(2465)	27 1/16	(687)
						40	(1016)	97 1/16	(2465)	27 1/16	(687)
	P6-5	16	(406)	27 1/16	(687)	36	(914)	97 1/16	(2465)	27 1/16	(687)
						40	(1016)	97 1/16	(2465)	27 1/16	(687)
	P8-1	28	(711)	N/A		48	(1219)	N/A		N/A	

NOTE: All operating polygons are non-certified.

Certified - Stationary Wood Ultimate Casement Polygon, Full Frame CE Marked											
Unit Type		Min Width		Min Height		Max Width		Max Height		Min Springline	
		in	mm	in	mm	in	mm	in	mm	in	mm
Insulating Glass 3/4"	P3	23	(584)	23 1/2	(597)	64	(1626)	96 1/16	(2440)	N/A	
						96 1/16	(2440)	64	(1626)	N/A	
	P4, P5	15	(381)	15 1/2	(394)	64	(1626)	96 1/16	(2440)	7 1/2	(191)
						96 1/16	(2440)	64	(1626)	7 1/2	(191)
	P6, P8	21	(533)	21 1/2	(546)	64	(1626)	96 1/16	(2440)	N/A	
						96 1/16	(2440)	64	(1626)	N/A	
Insulating Glass 1" Full Frame (Replacement N/A 1")	P3	23	(584)	23 1/2	(597)	88	(2235)	96 1/16	(2440)	N/A	
						96 1/16	(2440)	88	(2235)	N/A	
	P4, P5	15	(381)	15 1/2	(394)	88	(2235)	96 1/16	(2440)	7 1/2	(191)
						96 1/16	(2440)	88	(2235)	7 1/2	(191)
	P6, P8	21	(533)	21 1/2	(546)	88	(2235)	96 1/16	(2440)	N/A	
						96 1/16	(2440)	88	(2235)	N/A	

Maximum Non-Certified Frame Size - Full and Replacement - Stationary, Full Frame CE Marked				
Unit Type	Max Width		Max Height	
	in	mm	in	mm
P3, P4, P5, P6, P8 3/4" IG	64	(1626)	104	(2642)
	104	(2642)	64	(1626)
P3, P4, P5, P6, P8 1" IG - Full Frame (Replacement N/A 1")	88	(2235)	120	(3048)
	120	(3048)	88	(2235)

Wood Ultimate In-Sash Casement Polygon

Minimum and Maximum Guidelines and Certified Sizes: IZ3 / Stationary

Certified - Stationary Wood Ultimate Casement Polygon StormPlus IZ3											
Unit Type		Min Width		Min Height		Max Width		Max Height		Min Springline	
		in	mm	in	mm	in	mm	in	mm	in	mm
Insulating Glass 1" Full Frame (Replacement N/A 1")	P3	23	(584)	23 1/2	(597)	60	(1524)	107 9/16	(2732)	N/A	
						107 9/16	(2732)	60	(1524)		
	P4, P5	15	(381)	15 1/2	(394)	60	(1524)	107	(2718)	7.5	(191)
						107 9/16	(2732)	60	(1524)	7.5	(191)
	P6, P8	21	(533)	21 1/2	(546)	60	(1524)	107 9/16	(2732)	N/A	
						107 9/16	(2732)	60	(1524)		
	P3	23	(584)	23 1/2	(597)	72 5/8	(1845)	77 1/8	(1959)	N/A	
						77 1/8	(1959)	72 5/8	(1845)		
	P4, P5	15	(381)	15 1/2	(394)	72 5/8	(1845)	107	(2718)	7.5	(191)
						77 1/8	(1959)	72 5/8	(1845)	7.5	(191)
	P6, P8	21	(533)	21 1/2	(546)	72 5/8	(1845)	77 1/8	(1959)	N/A	
						77 1/8	(1959)	72 5/8	(1845)		
Insulating Glass 3/4" Full Frame (Replacement N/A 3/4")	P3	23	(584)	23 1/2	(597)	36	(914)	72 1/2	(1842)	N/A	
						72 1/2	(1842)	36	(914)		
	P4, P5	15	(381)	15 1/2	(394)	36	(914)	72 1/2	(1842)	7.5	(191)
						72 1/2	(1842)	36	(914)	7.5	(191)
	P6, P8	21	(533)	21 1/2	(546)	36	(914)	72 1/2	(1842)	N/A	
						72 1/2	(1842)	36	(914)		

Product	Air Tested to psf	Water Tested to psf	Structural Overload Tested to psf	Certification Rating	Max Width In	Max Width mm	Max Height In	Max Height mm
Wood Ultimate Casement Polygon Stationary 3/4" (Full Frame and Replacement)	1.57	7.5	75	CW-PG50	64	1626	97 1/8	2467
Wood Ultimate Casement Polygon Stationary 1" (Full Frame)	1.57	7.5	75	CW-PG50	72	1829	72 1/16	1830
Wood Ultimate Casement Polygon Stationary 1" (Full Frame)	1.57	7.5	75	CW-PG50	88	2235	97 1/16	2465
Product	Air Tested to psf	Water Tested to psf	Structural Overload Tested to psf	Certification Rating	Max Width In	Max Width mm	Max Height In	Max Height mm
Wood Ultimate Casement Polygon Picture 1" StormPlus IZ3 (Full Frame)	1.57	9.75	97.5	CW-PG65	60	1524	107 9/16	2732
Wood Ultimate Casement Polygon Picture 1" StormPlus IZ3 (Full Frame)	1.57	9.75	97.5	CW-PG65	72 5/8	1845	78 5/64	1983
Wood Ultimate Casement Polygon Picture 1" StormPlus IZ3 (Full Frame)	1.57	9.75	97.5	CW-PG65	78 5/64	1959	72 5/8	1845
Wood Ultimate Casement Polygon Picture 1" StormPlus IZ3 (Full Frame)	1.57	9.75	97.5	CW-PG65	107 9/16	2732	60	1524

Measurement Conversions and Egress Openings

In-Sash Polygon					
Unit Measurements		Width		Height	
From	To				
Rough Opening		in	mm	in	mm
OM of Frame	Rough Opening	+1	(25)	+1/2	(13)
Masonry Opening w/BMC	Rough Opening	+2 5/8	(67)	+1 15/16	(49)
Sash OM	Rough Opening	+2 11/16	(68)	+3 1/8	(79)
Sash		in	mm	in	mm
Glass Size	OM of Sash	+3 1/64	(77)	+3 1/64	(77)
Glass		in	mm	in	mm
Daylight Opening	Glass	+1 3/32	(28)	+1 3/32	(28)

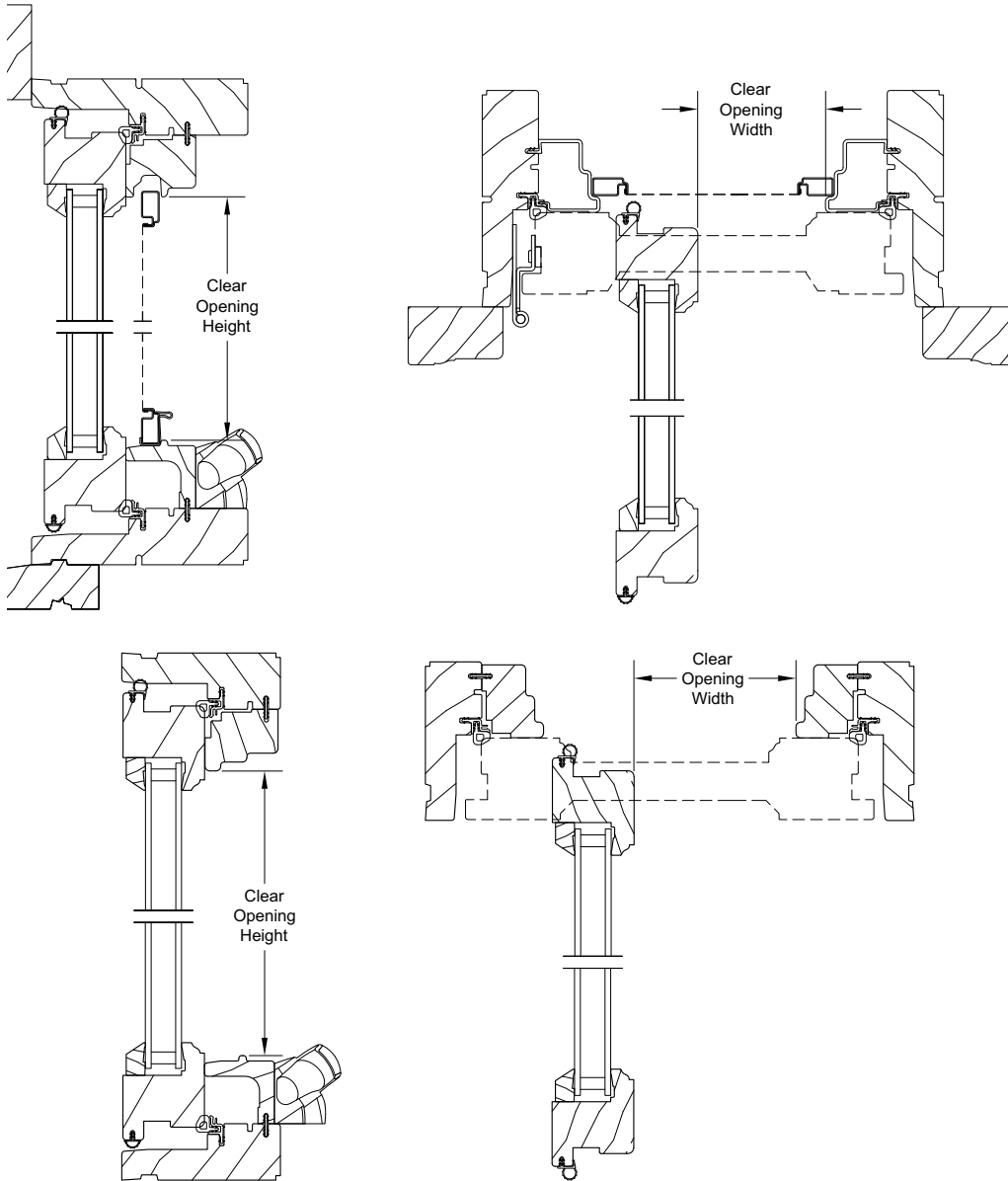

Slope to Angle and Angle to Pitch Conversions

Slope to Angle / Degree Conversions					
Slope	Angle	Degree / Minutes	Slope	Angle	Degree / Minutes
1/12	4.76	4 degree 46'	13/12	47.29	47 degree 14'
2/12	9.46	9 degree 28'	14/12	49.40	49 degree 24'
3/12	14.04	14 degree 2'	15/12	51.34	51 degree 20'
4/12	18.43	18 degree 26'	16/12	53.13	53 degree 8'
5/12	22.62	22 degree 37'	17/12	54.78	54 degree 47'
6/12	26.57	26 degree 34'	18/12	56.31	56 degree 19'
7/12	30.26	30 degree 15'	19/12	57.72	57 degree 43'
8/12	33.69	33 degree 41'	20/12	59.04	59 degree 2'
9/12	36.87	36 degree 52'	21/12	60.26	60 degree 15'
10/12	39.81	39 degree 48'	22/12	61.39	61 degree 23'
11/12	42.51	42 degree 31'	23/12	62.45	62 degree 27'
12/12	45.00	45 degree 0'	24/12	63.43	63 degree 26'

Angle to Pitch Conversions							
Angle	Pitch	Angle	Pitch	Angle	Pitch	Angle	Pitch
1	0.21/12	26	5.85/12	51	14.82/12	76	48.13/12
2	0.42/12	27	6.11/12	52	15.36/12	77	51.98/12
3	0.63/12	28	6.38/12	53	15.92/12	78	56.56/12
4	0.84/12	29	6.65/12	54	16.52/12	79	61.73/12
5	1.05/12	30	6.93/12	55	17.14/12	80	68.06/12
6	1.26/12	31	7.21/12	56	17.79/12	81	75.77/12
7	1.47/12	32	7.50/12	57	18.48/12	82	85.38/12
8	1.69/12	33	7.79/12	58	19.20/12	83	97.73/12
9	1.90/12	34	8.09/12	59	19.97/12	84	114.17/12
10	2.12/12	35	8.40/12	60	20.78/12	85	137.16/12
11	2.33/12	36	8.72/12	61	21.65/12	86	171.61/12
12	2.55/12	37	9.04/12	62	22.57/12	87	228.97/12
13	2.77/12	38	9.38/12	63	23.55/12	88	343.64/12
14	2.99/12	39	9.72/12	64	24.60/12	89	687.48/12
15	3.22/12	40	10.07/12	65	25.73/12		
16	3.44/12	41	10.43/12	66	26.95/12		
17	3.67/12	42	10.80/12	67	28.27/12		
18	3.90/12	43	11.19/12	68	29.70/12		
19	4.13/12	44	11.59/12	69	31.26/12		
20	4.37/12	45	12.00/12	70	32.97/12		
21	4.61/12	46	12.43/12	71	34.85/12		
22	4.85/12	47	12.87/12	72	36.93/12		
23	5.09/12	48	13.33/12	73	39.25/12		
24	5.34/12	49	13.80/12	74	41.85/12		
25	5.60/12	50	14.30/12	75	44.78/12		

Wood Ultimate In-Sash Casement Polygon

Section Details: Stationary Full Frame

Scale: 3" = 1' 0"

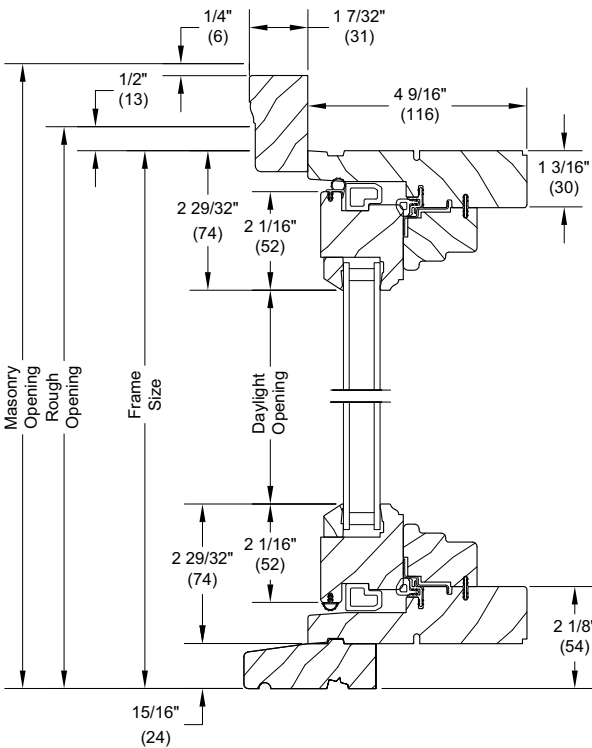

Head Jamb and Sill - Sloped Sill Cover

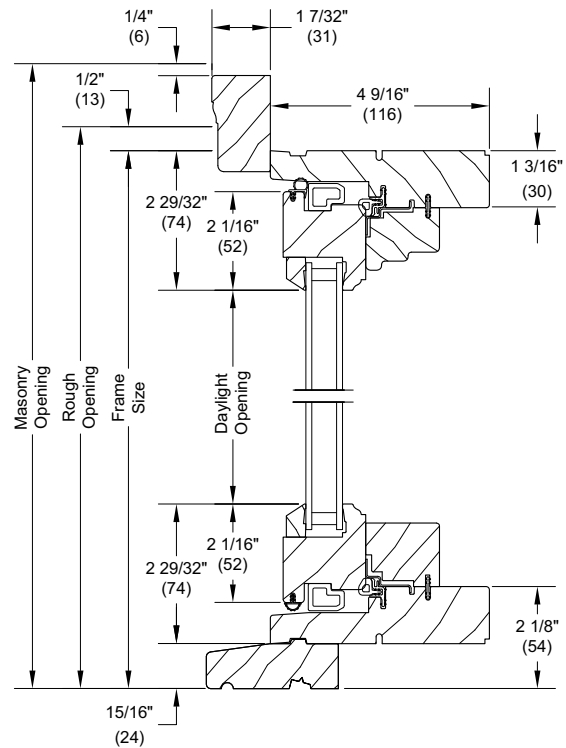

Head Jamb and Sill - Flat Sill Cover

Head Jamb and Sill - Sloped Sill Cover

- P3 - 3 through 22
- P4 - 1, 2, 3, 4, 11, 12, 13, 14, 15, 16, 17
- P5 - 2, 7, 8
- P6 - 1, 2, 3, 4, 6
- P8 - 1, 2, 3, 4

Head Jamb and Sill - Flat Sill Cover

- P3 - 1, 2
- P4 - 5, 6, 7, 8, 9, 10
- P5 - 1, 3, 4, 5, 6, 9, 10, 11, 12, 13, 14, 15, 16
- P6 - 5, 7, 8

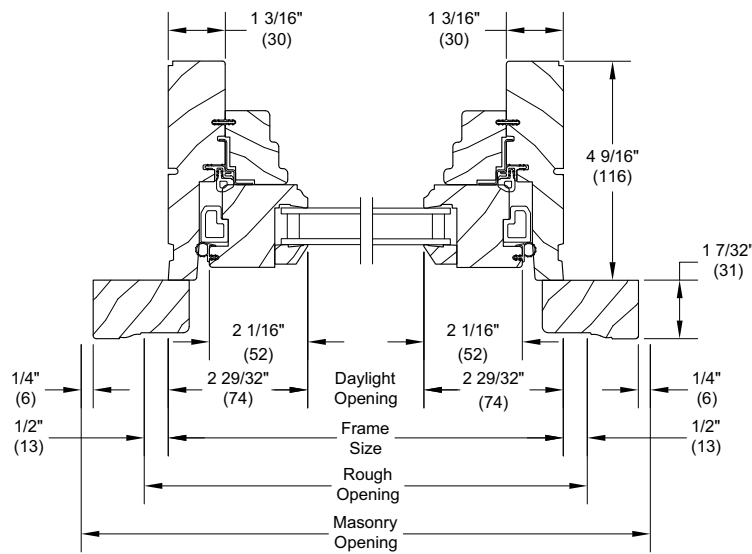

Jambs

Wood Ultimate In-Sash Casement Polygon

Section Details: Stationary IZ3 - 3/4" (19) and 1" (25) IG

Scale: 3" = 1' 0"

3/4" (19) IG

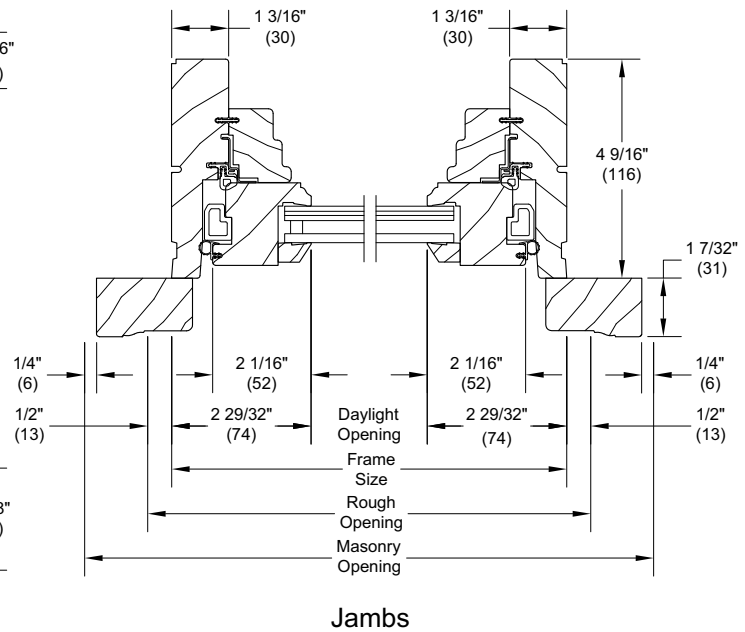
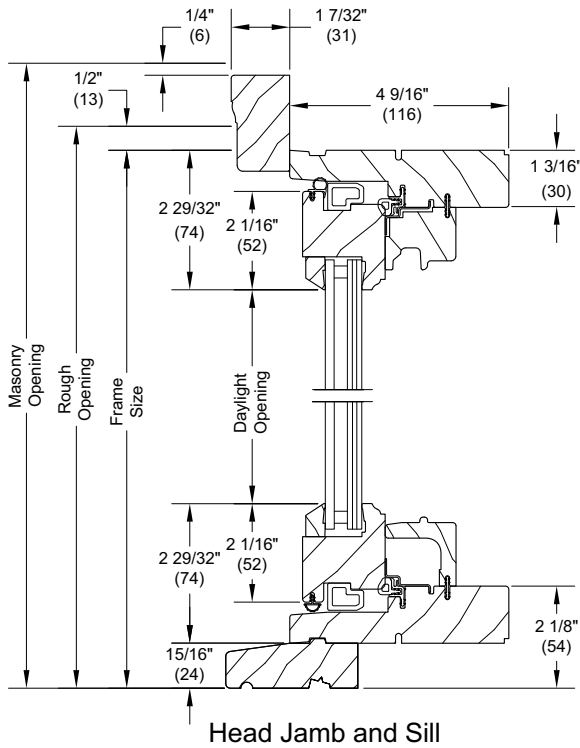

1" (25) IG

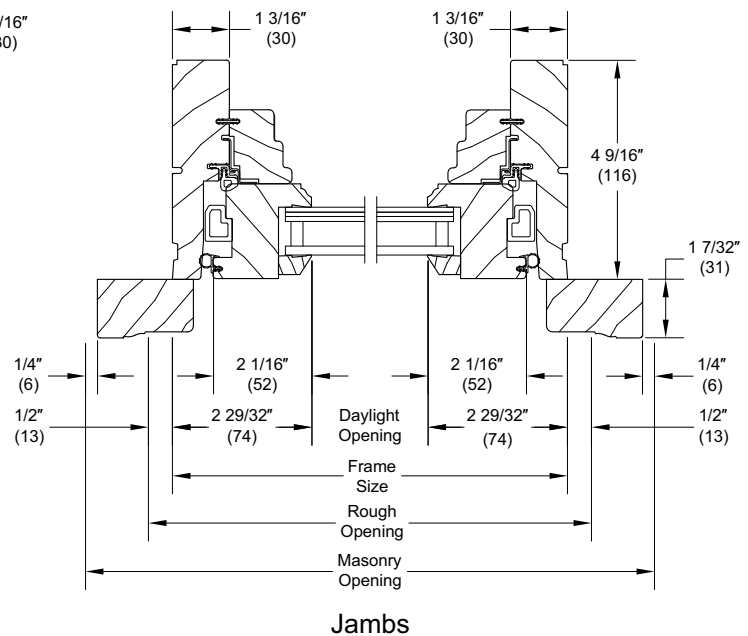
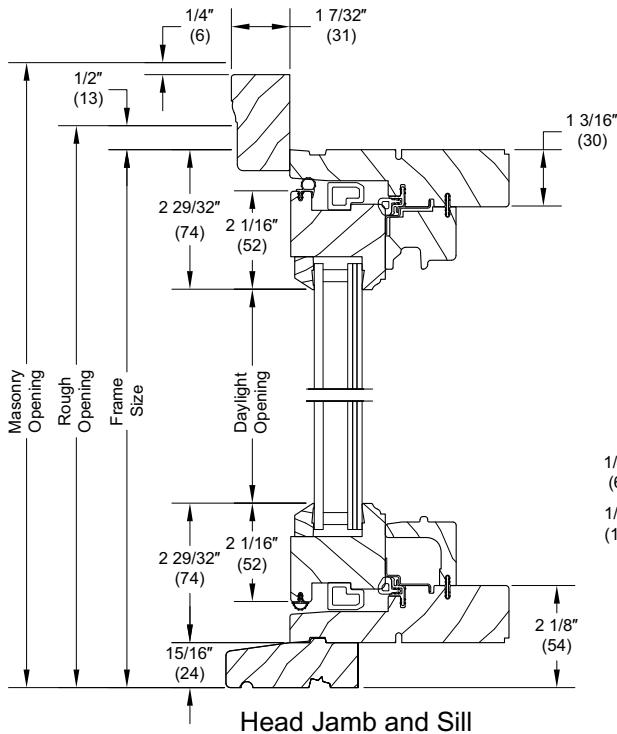

Wood Ultimate In-Sash Casement Polygon

Section Details: Stationary Replacement Frame

Scale: 3" = 1' 0"

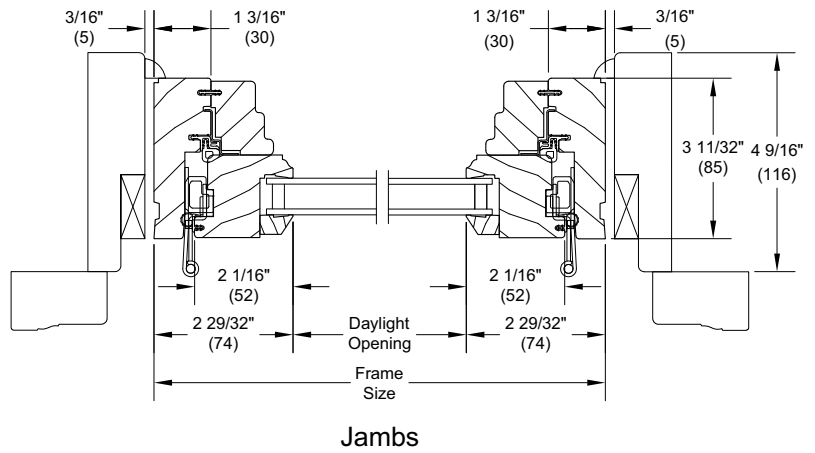
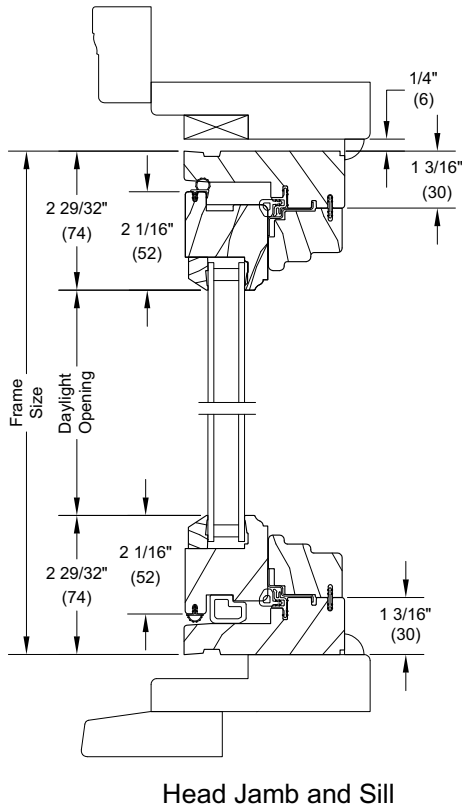
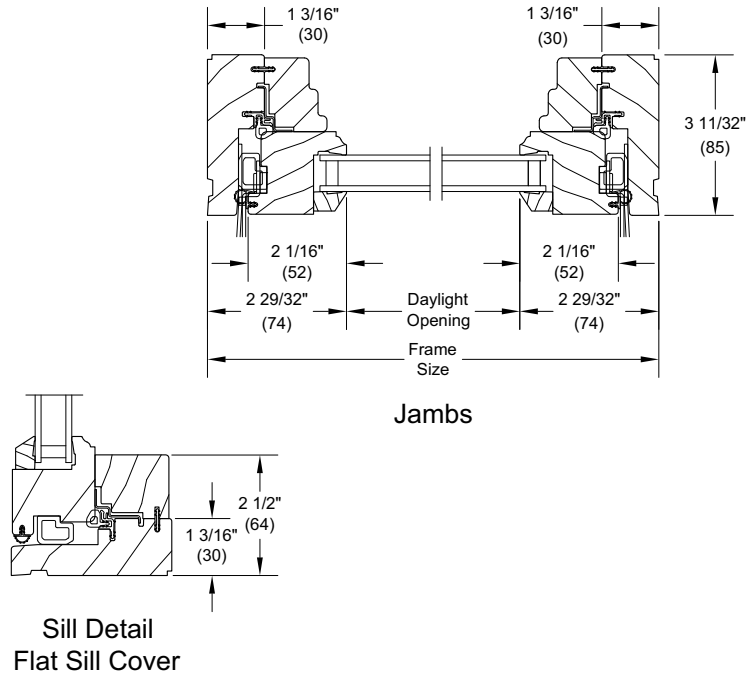
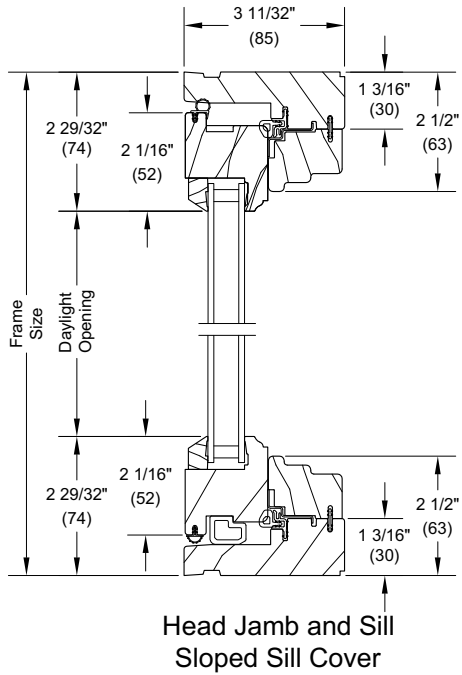

Wood Ultimate In-Sash Casement Polygon

Section Details: Stationary in DH Replacement Frame

Scale: 3" = 1' 0"

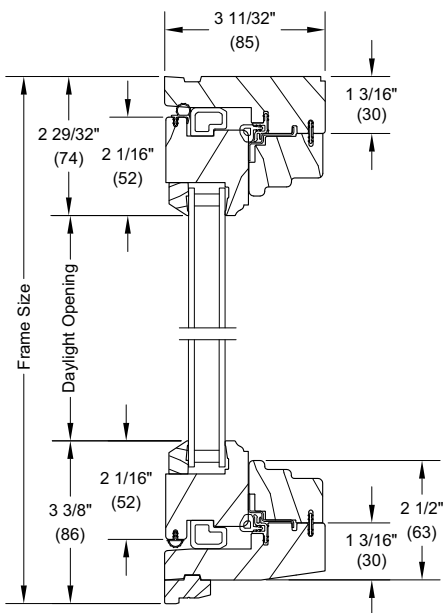

**Head Jamb and Sill
Sloped Sill Cover**

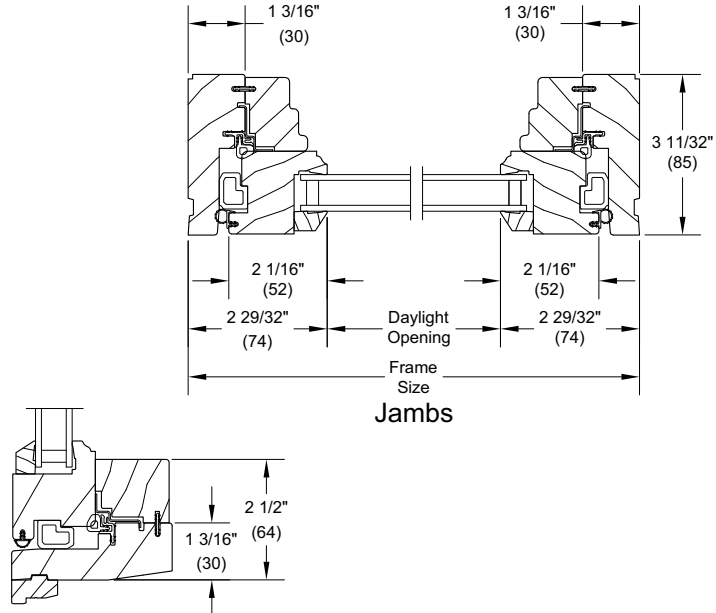

**Sill Detail
Flat Sill Cover**

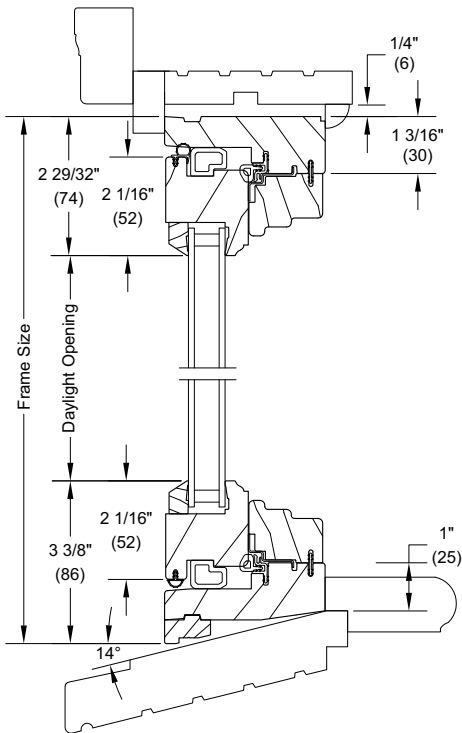

Head Jamb and Sill

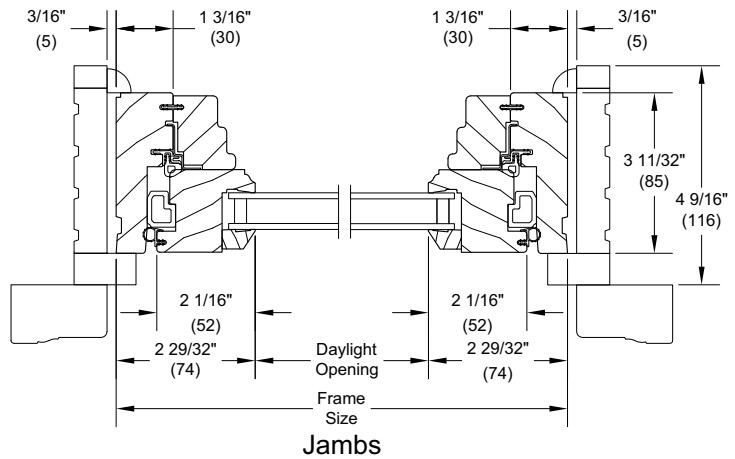

Jamb

Wood Ultimate In-Sash Casement Polygon

Section Details: Operable Full Frame

Scale: 3" = 1' 0"

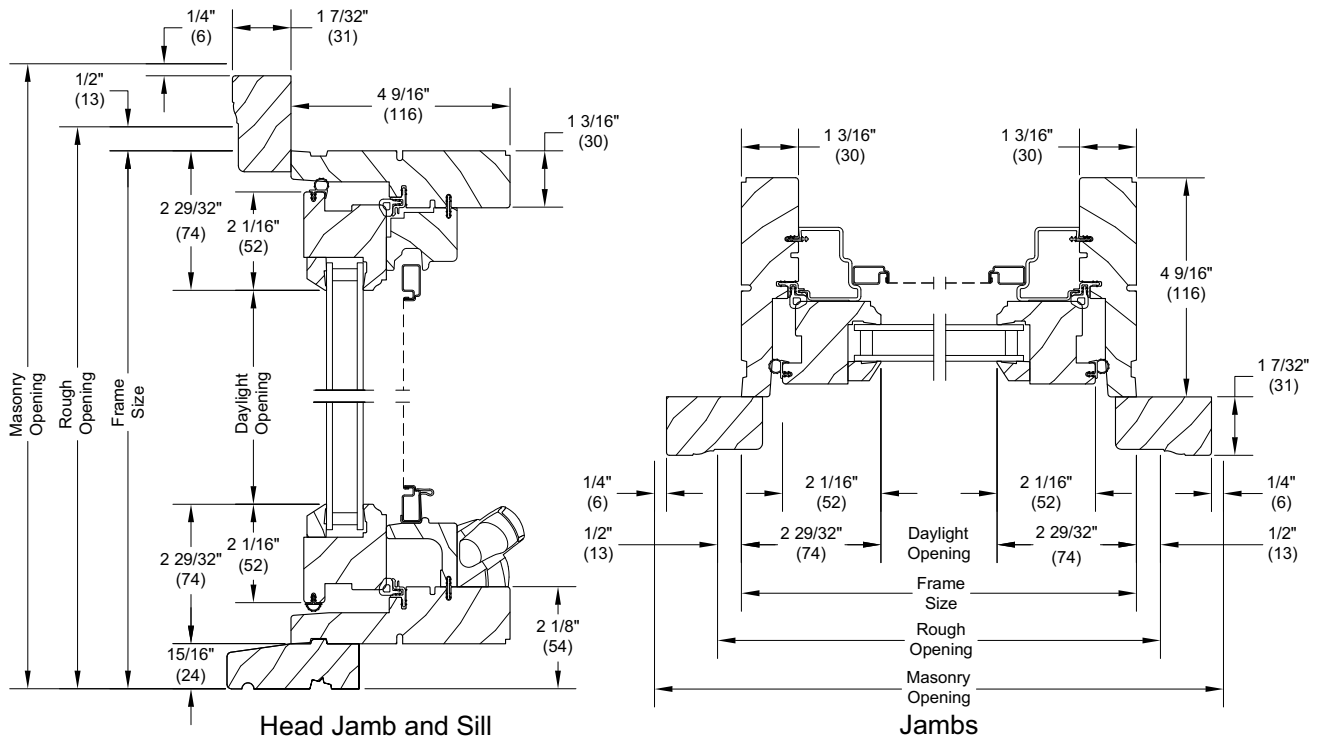

Wood Ultimate In-Sash Casement Polygon

Section Details: Operable Replacement Frame

Scale: 3" = 1' 0"

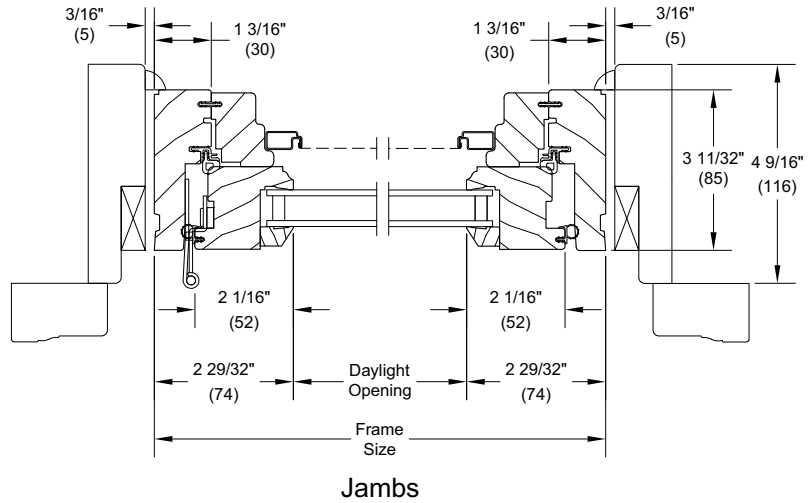
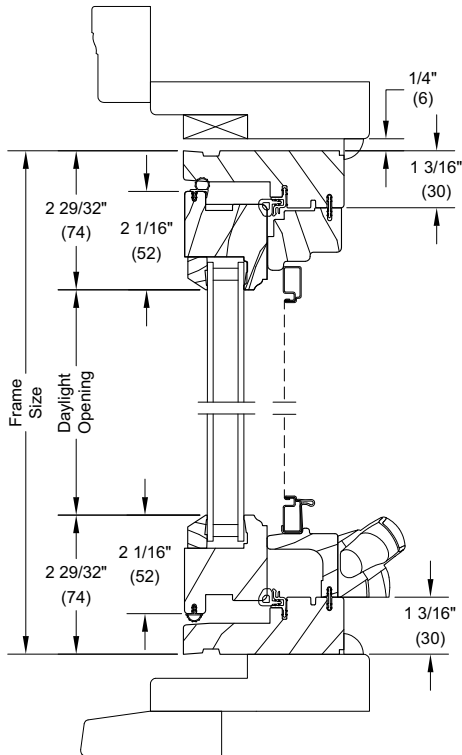
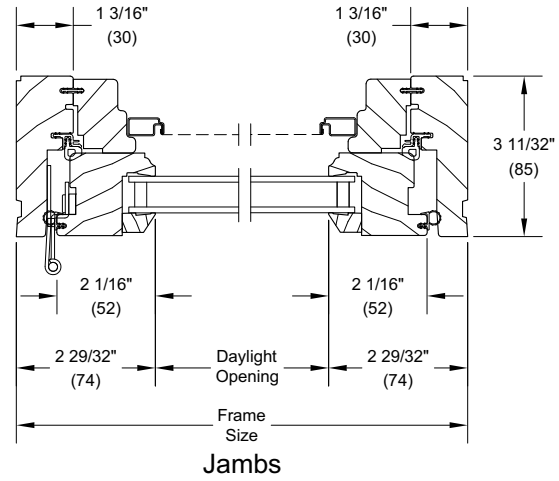
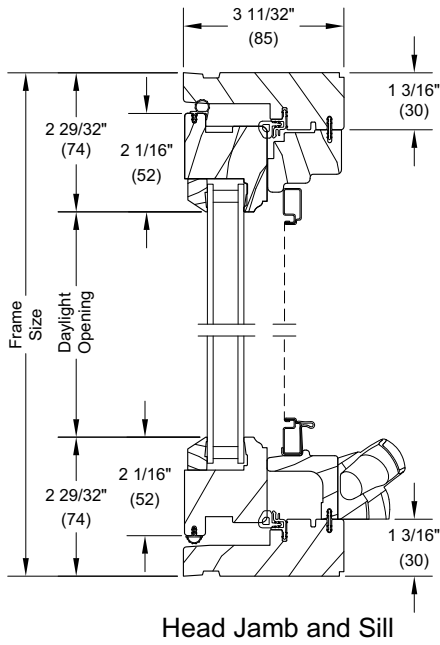

Wood Ultimate In-Sash Casement Polygon

Section Details: Operable Replacement Frame in Double Hung Frame

Scale: 3" = 1' 0"

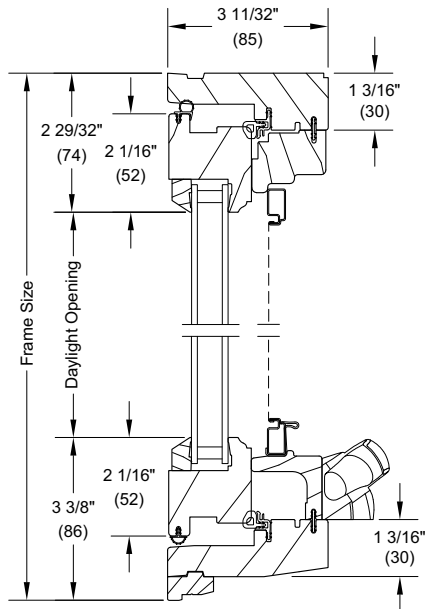

Head Jamb and Sill

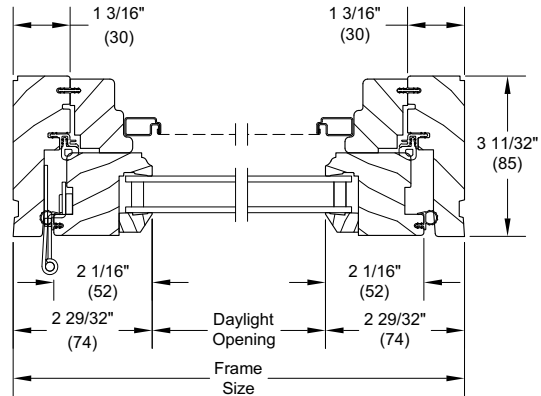

Jambs

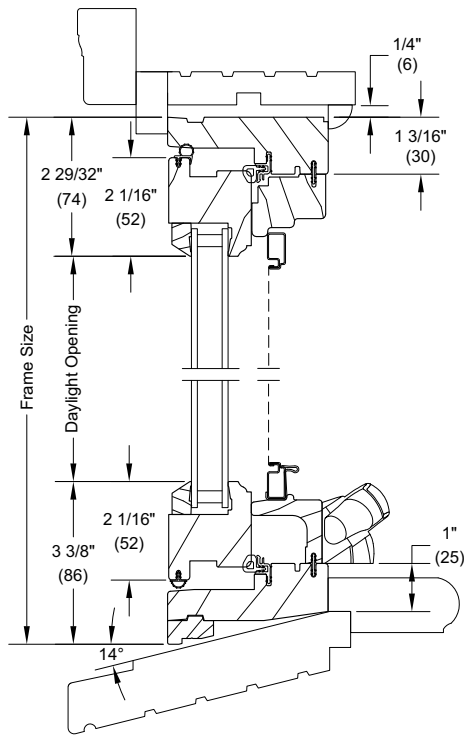

Head Jamb and Sill

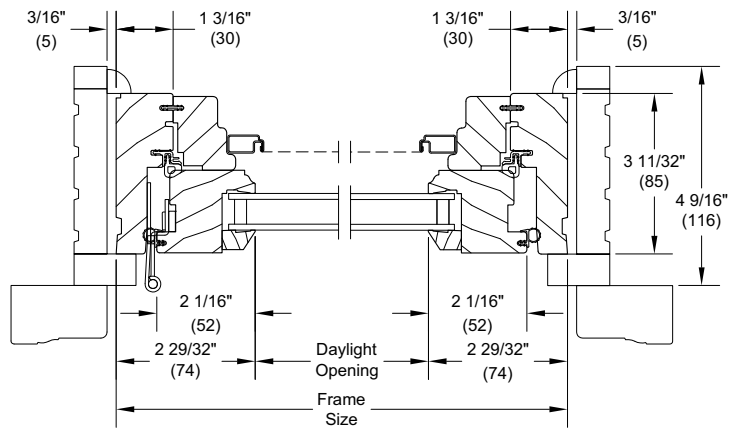

Jambs

Wood Ultimate In-Sash Casement Polygon

Section Details: Stationary In-Sash Casement Polygon Mullion Options

Scale: 3" = 1' 0"

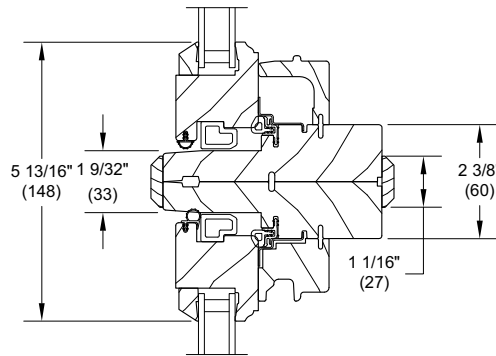

Horizontal Mullion

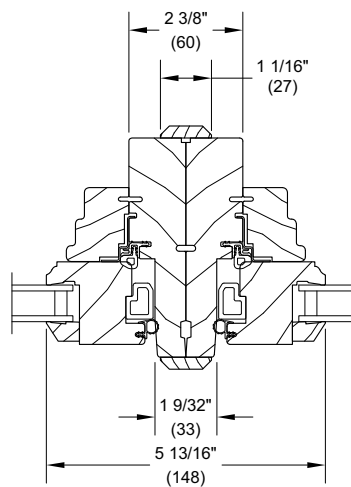

Vertical Mullion

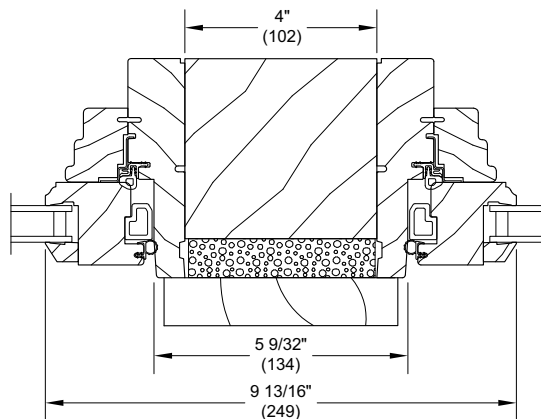

4" Space Mull

Wood Ultimate In-Sash Casement Polygon

Section Details: Operable In-Sash Casement Polygon Mullion Options

Scale: 3" = 1' 0"

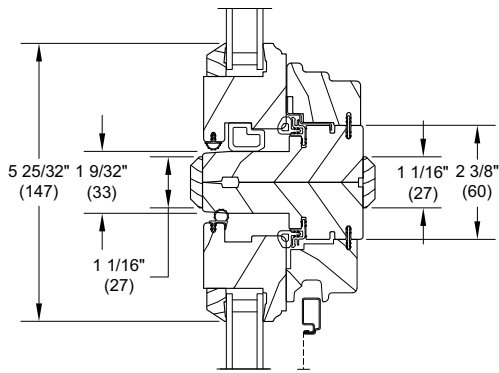

Horizontal Mullion - Stationary/Operator

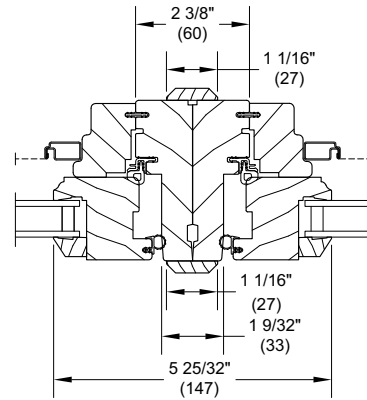

Vertical Mullion - Operator/Operator/Direct Mull

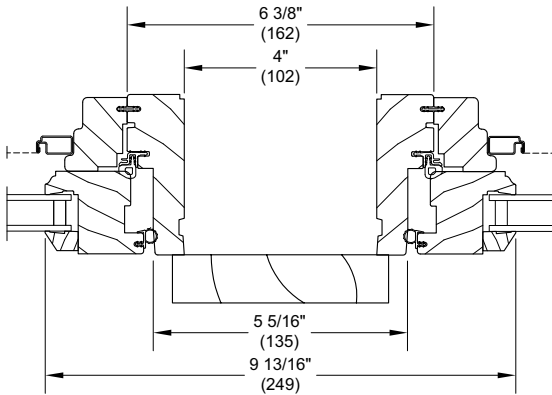

Vertical Mullion - with 4" Space Mull
Operator/Operator

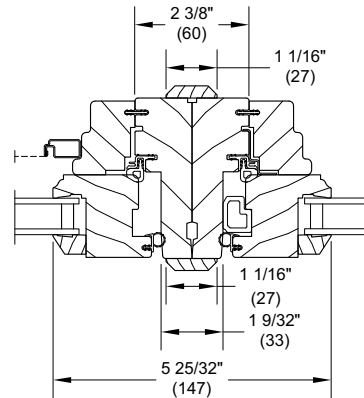

Vertical Mullion - Operator/Picture/Direct Mull

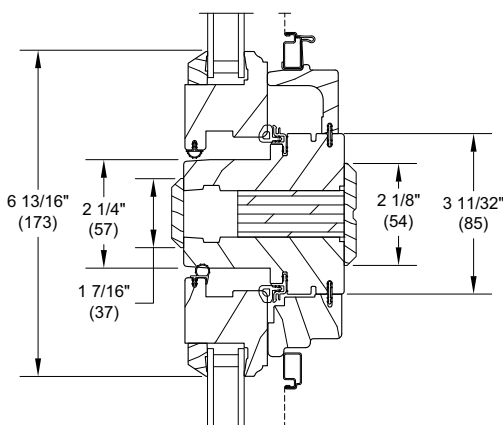

Horizontal Mullion - LVL Operator/Operator

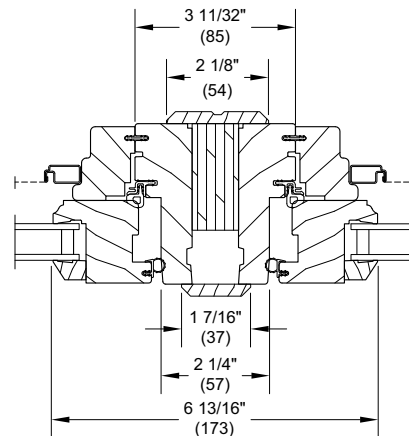

Vertical Mullion - LVL Operator/Operator

Configuration Limits

3 9/16" Bottom Rail Limitations		
Shape	Standard Bottom Rail	Standard and Wide Bottom Rail
All P3	X	
P4 - 1,2,3,4	X	
P4 - 5,6		X
P4 - 7 through 17	X	
P5 - 1		X
P5 - 2,3,4	X	
P5 - 5,6		X
P5 - 7 through 12	X	
P5 - 13, 14		X
P5 - 15, 16	X	
P6 - 1,2,3,4	X	
P6 - 5		X
P6 - 6,7,8	X	
P8 - 1,2,3,4	X	

WUCA Sub sill Rules		
Shape	Subsill by default	BMC all around
P3 - 1,2,5,9,10,17,18	X	
P3 - 3,4,6,7,8,1,12,13,14,15,16,19,20,21,22		X
P4 - 1,2,5,6,7,8,9,10,13,14	X	
P4 - 3,4,11,12,15,16,17		X
P5 - 1,3,4,5,6,9 through 16	X	
P5 - 2,7,8		X
P6 - 1,2,3,4		X
P6 - 5,6,7,8	X	
P8 - 1,2,3,4		X

Polygon Shape Reference

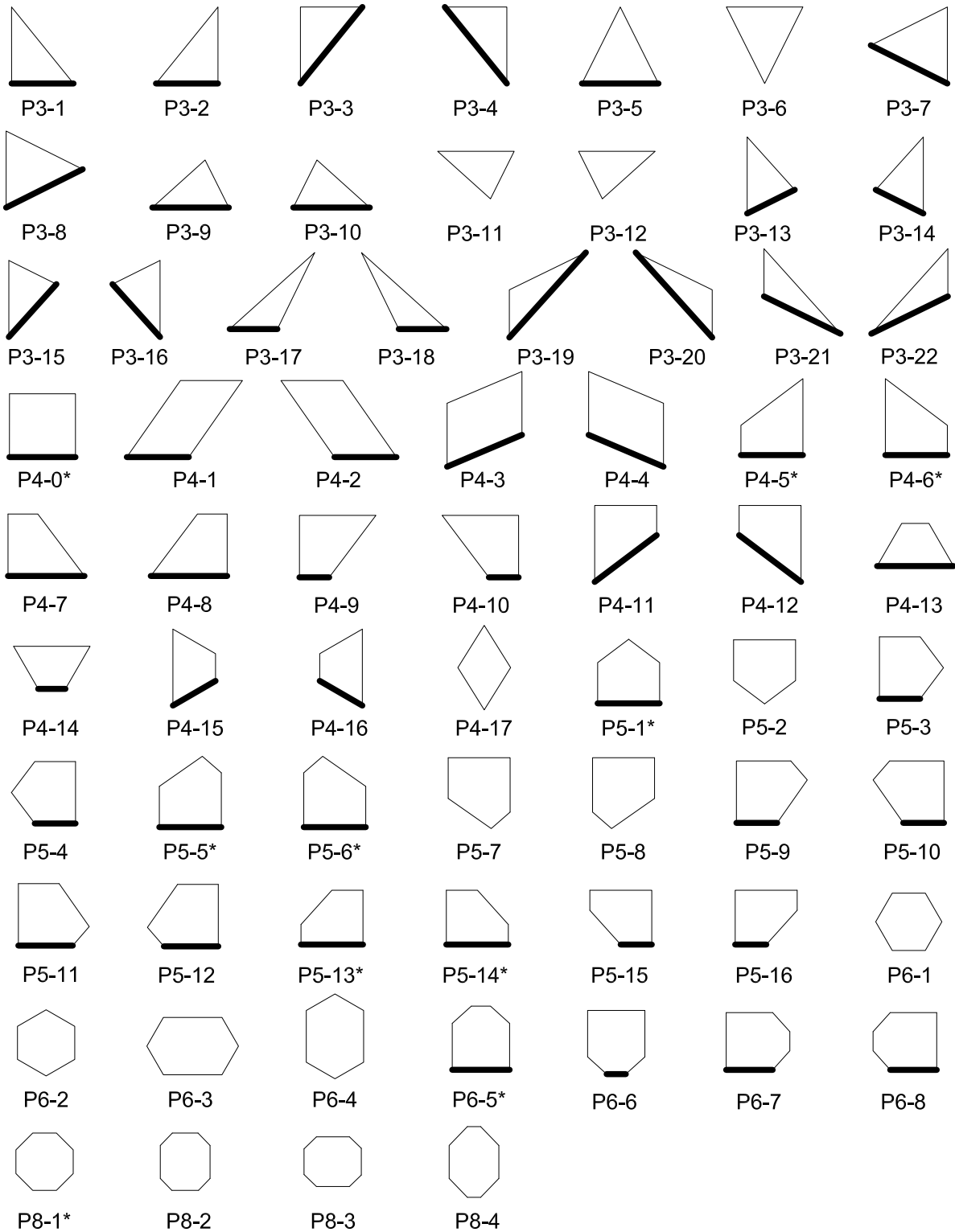

NOTE: Please contact your Marvin representative for availability and more information.

NOTE: Dark line indicates subsill placement.

Field Measurement

Operator and Stationary In-Sash Casement Polygon Conversion from Field Measurement to Frame OSM		
Width		
Condition	Formula	
If blind stop width is 1/2" (13) or less	Frame OM Width - inside opening width - 0.375	
Height		
Condition	Type of Sill Bevel	Formula
If old sill angle is less than 8°	Flat-bottom Sill	Frame OM Height = inside opening height - 0.250
If old sill angle is greater than 8° and less than 14°	8-degreee-bottom sill	Frame OM Height = inside opening height - 0.0563 (frame IM height has a .250 clearance)
If old is angle is 14° of greater	14-degree bottom sill	Frame OM Height = inside height = .431 (frame OM Height has a .250 clearance)

Interior Frame Size to Frame Size (exterior)	
Frame Bevel	Conversions
0°	0
8°	+3/16" (5)
14°	+11/16" (17)

