

Integrity All Ultrex Series Windows

1/2" Mull Reinforcement Instruction for Field Application

ABSTRACT: The following instructions are intended for use in assembling multiple wide and/or high configurations of Integrity All Ultrex windows using field-applied mull kits. Please read through these instructions thoroughly and in their entirety before attempting to mull windows.

IMPORTANT

More than one mull kit may be necessary. Field mulls beyond factory mulled configurations are not recommended. Maximum dimensions are 2W x 2H up to 96" x 96" R.O. or a 4W up to 114" x 78" R.O. Field mulled windows are not certified to the advertised DP ratings of individual windows.

NOTE: Numbers listed in parentheses () are metric equivalents to the nearest whole number.

Mull Kit Parts

- 1 - Mull reinforcement (MRF)
- 2 - Mull bracket
- 2 - Mull plugs
- 4 - Rivets
- 1 - Sill mull bracket
- 2 - Flat sill structural brackets
- 6 - 90-degree bent structural brackets with 8-#7 x 5/16" screws
- 2 - Mull covers (interior and exterior)
- 2 - Nailing fin connector gaskets
- 2 - MRF T-Slot connections
- 4 - #8 x 2" screws
- 2 - Mull strap (2W2H) with 4-#8 x 1" screws.

NOTE: Inspect the mull kit to ensure that there are no damaged or missing parts. Parts listed above are included in each kit. More than one kit may be needed depending on configuration.

Tools and Supplies Needed

- Rubber mallet
- Rivet gun
- Caulking gun
- Hacksaw
- Silicone sealant
- Screw gun/drill with 3/16" drill bit
- Screwdriver with a #2 Phillips head bit



CAUTION!

Always wear the proper eye and ear protection when using power tools. Follow all manufacturers' instructions for application and clean up of sealants.



WARNING!

Drilling, sawing, sanding or machining wood products can expose you to wood dust, a substance known to the State of California to cause cancer. Avoid inhaling wood dust or use a dust mask or other safeguards for personal protection. For more information go to www.P65Warnings.ca.gov/wood.

Preparing the Windows for Mulling

1. Remove and properly discard all shipping material.
2. Inspect the unit to make sure it is the right size, color, etc. and that there is no damage. If you find something wrong with your windows, contact your local Integrity representative and provide them with customer service number located in one of the corners of the glass. See [Figure 1](#).



Figure 1

3. Remove and set aside all screens and loose hardware.
4. Lay the units to be mullered on a flat sturdy surface exterior side up. Remove all nailing fin, if present, from windows at the mull and perpendicular to the mull. See [Figure 2](#).

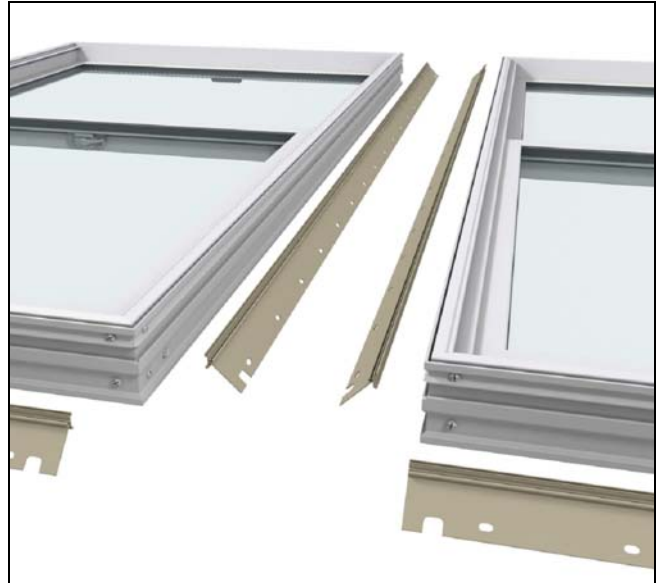

Figure 2

5. For J-Channel applications: At the corners of the mullion, carefully remove the outer wall of the accessory kerf with a hacksaw. See [Figure 3](#). (This operation does not need to be done at the sill corners of sliding window products.)

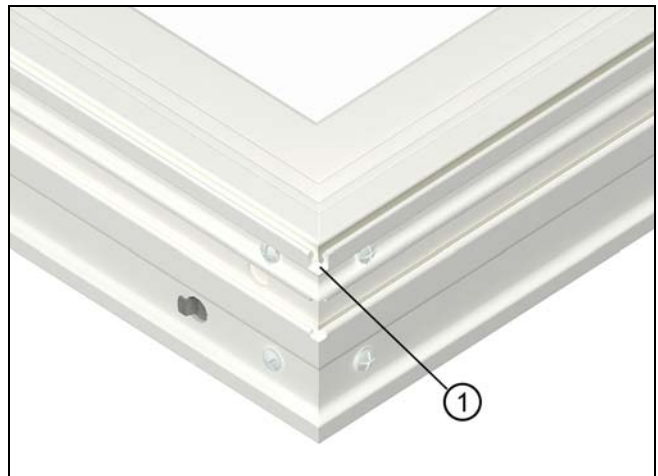

Figure 3

1	Notch corner
---	--------------

Mulling the Windows

1. Set the units to be mullied close together and slide the mull T slot connector down the nailing fin channel on both units. If necessary pound the connector in with a rubber mallet or plastic hammer. See [Figure 4](#).



Figure 4

2. Insert the mull plugs with the injection hole oriented toward the exterior. See [Figure 5](#).



Figure 5

1	Mull plug
---	-----------

3. Loosen the screws from the interior corners of the windows on both ends of the mull. See [Figure 6](#). (Remove screws from sill completely for sliding window products.)



Figure 6

1	Loosen screws
---	---------------

4. Place the brackets as shown. Fasten using screws loosened in previous steps. See [Figure 7](#). Use the smaller bracket for sill mullion joints on sliding window products. See [Figure 8](#).



Figure 7

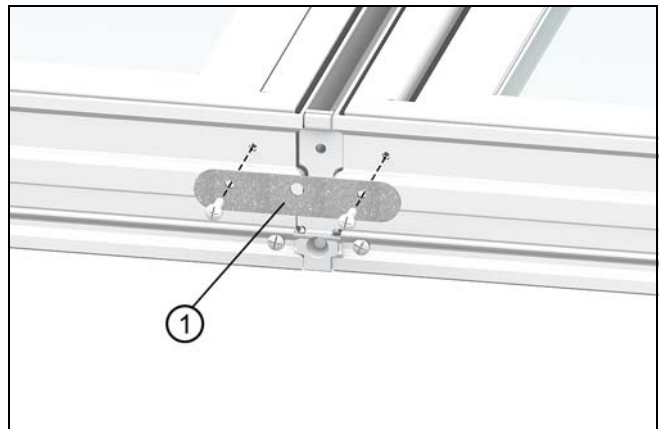

Figure 8

1	Sill mull bracket
---	-------------------

5. Drill out first layer of Ultrex using holes in end of bracket as a guide. Fasten all rivets. See [Figure 9](#). (Sill mull brackets on sliding window products do not require rivets.)



Figure 9

6. Apply silicone along the exterior side of the mull. [Figure 10](#).



Figure 10

7. Install the exterior mull cover. These should be flush with the interior edge of the accessory kerf to allow for J-channel application. You may have to seat the cover with a rubber mallet or wood block and hammer. Flip the assembly over and install the interior mull cover in the same manner. See [Figure 11](#).



Figure 11

NOTE: Take care when handling or flipping the assembly.

Sealing the Assembly

NOTE: Be sure the sealant used is compatible with any flashing materials used to install the window into the rough opening.

8. Using a high quality sealant loaded into a caulking gun, insert the nozzle into the injection hole on the mull plug and inject with sealant. You will know there is enough sealant injection when overflow appears in the nailing fin channel below the injection hole and around the cover above the injection hole. See [Figure 12](#).

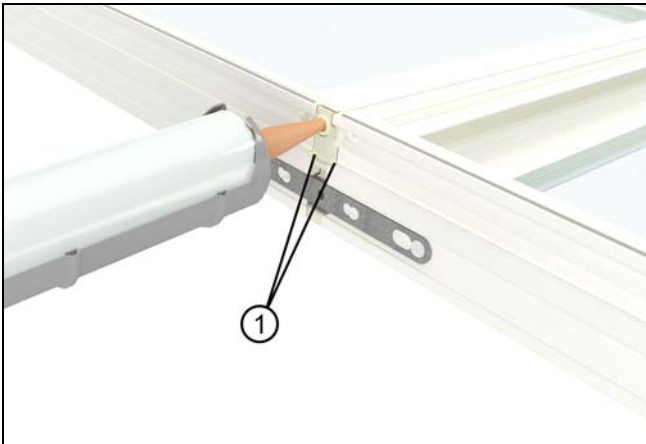

Figure 12

1	Squeeze out
---	-------------

9. Replace the nailing fin on the frame perpendicular to the mull. Leave sill nail fin off at this point. Slide the nailing fin in from the corners all the way until they butt up against each other over the mull plugs. Install the nail fin connector gaskets and seal around the edges of the connector. See [Figure 13](#).



Figure 13

10. Install jamb and head jamb brackets. Apply 90-degree bent structural brackets within 1 1/8" (29) of either side of the mull with 5/8" screws on both ends. Install a third 90-degree bent structural bracket into the mull end with 2" screws on both ends. Apply a third bracket between the first two centered on the mull. Follow the instructions sent with the brackets. See [Figure 14](#).



Figure 14 Jamb/Head Jamb bracket placement

11. Install Sill brackets. Apply two "flat" sill structural brackets within 1 1/8" of either side of the mull. Apply one 90 degree bent structural bracket between the first two, centered on the mull. See [Figure 15](#).

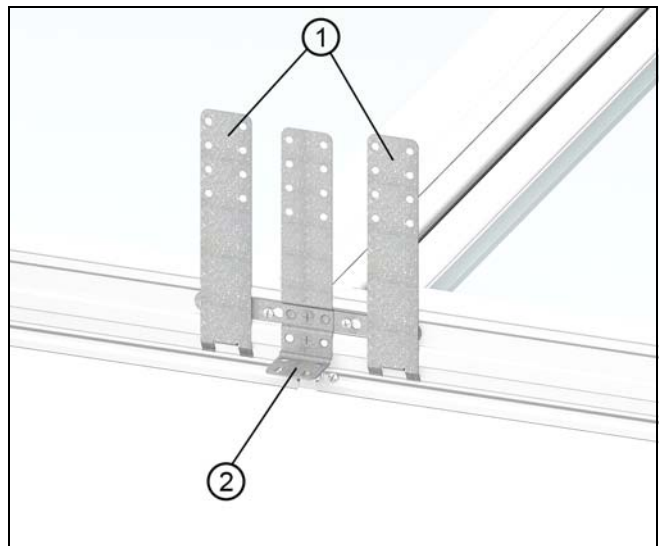

Figure 15 Sill bracket placement

1	Flat sill structural bracket
2	90-degree bent structural bracket

2W x 2H Configurations

NOTE: When mulling All Ultrex windows in 2W X 2H configuration, you will need three mull kits.

IMPORTANT

Double Hung and Single Hung Operators cannot be mulled above other units.

12. Using the techniques outlined in the previous steps, prep, and mull the two vertical sections first (horizontal mulls). Plugs will not be used at the vertical mull location where the metal strap will eventually be applied. Mull the two vertical sections together (vertical mull). Apply 2W2H strap across vertical mull into horizontal mulls with 1" screws. Apply them to both the interior and exterior of the mulls. Do not apply nailing fin until the entire assembly is complete. See [Figure 16](#).

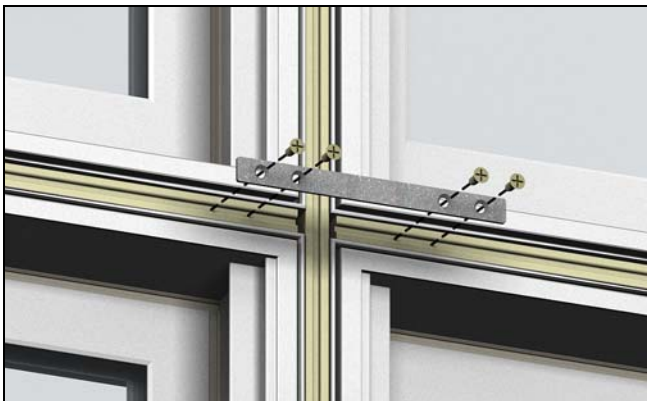

Figure 16

13. Seal exterior end plugs (see [Figure 12](#).)

14. Apply silicone between the horizontal and vertical mull covers. See [Figure 17](#).

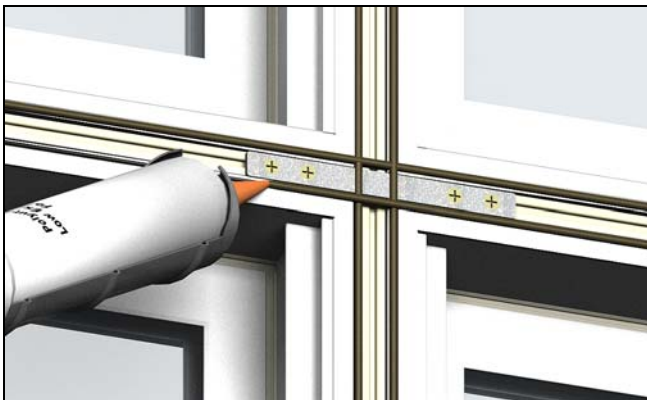

Figure 17

15. Cut a notch in the continuous mull cover legs to go around the 2W2H mull straps.



Figure 18

16. Install the vertical mull cover first, then the horizontal mull covers. Seat the covers with a rubber mallet or wood block and hammer, make sure the joints are tight. See [Figure 19](#).



Figure 19

17. Apply nailing fin, nailing fin gasket connectors and 90-degree bent structural brackets on the jamb and head jamb mullion joints. See [Figure 20](#).

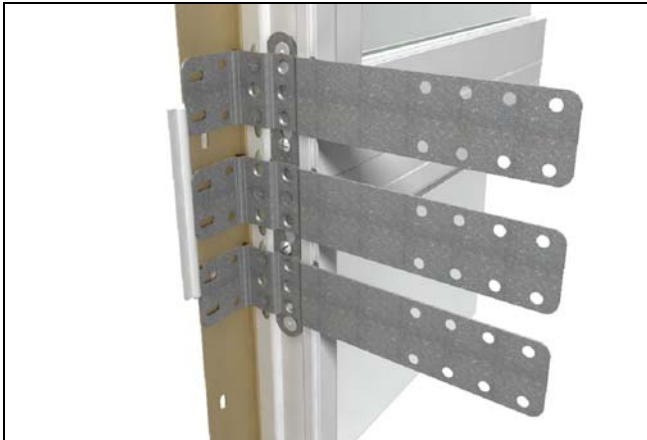

Figure 20 Jamb/Head Jamb

18. For sill mullion joints, take previously removed sill nail fin and cut sill nail fin at each mullion joint location and shorten the ends of each piece by 3"-3.5" near each mullion to allow space for the flat sill structural brackets. Slide brackets and nail fin pieces into the sill T-slot. See [Figure 21](#)

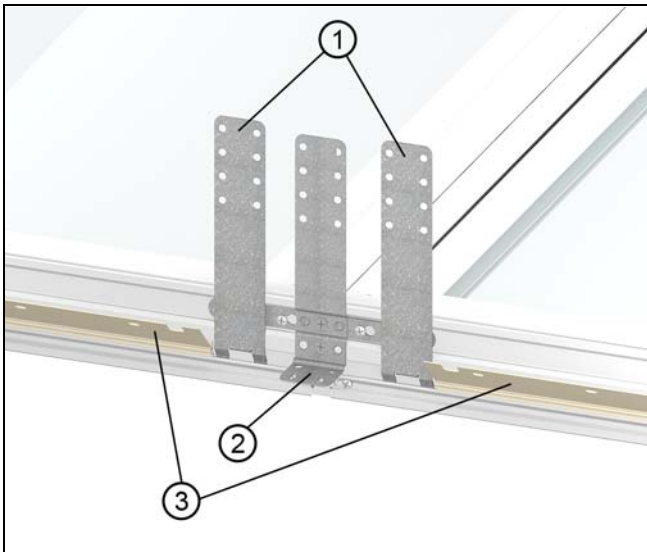

Figure 21 Sill bracket placement

1	Flat sill structural bracket
2	90-degree bent structural bracket
3	Nailing fin