

Ultimate Lift and Slide Site Preparation Guide for Performance Sill

General Information

The Marvin Ultimate Lift and Slide door Performance Sill option offers performance against air and water infiltration. The Performance Sill is available across all ULS sizes and configurations though WDMA DP 30 certification is limited to Clad, uni-directional doors up to CN 200100 with panels no larger than CN 50100. See ADM for details. Authorized installers are able to adjust the sill throughout the life of the door. The Ultimate Lift and Slide Performance Sill Site Preparation Guide will provide the necessary information to properly prepare the wall opening for ease of installation and operational integrity.

Site preparation begins with prepping the opening for the Performance Sill system; the foundation of the Lift and Slide Door. The Performance Sill can be installed on top of the sub floor or into a recessed slot that is open to the exterior (open face slot). All installations require a moisture proof barrier between the Performance Sill and subfloor or slot. The subfloor or slot must support the sill height variance requirement of 1/32" (1) maximum across the entire sill length. The sill will arrive factory assembled for units up to 23 1/2' (7163). For units over 23 1/2' (7163) Performance Sills require field assembly.

In conjunction with the sill, the framing of the rough opening must be installed plumb, square, and true within 1/8" (3). The header must be flat and designed to uphold the deflection requirement of not more than 1/8" (3) over the entire length of the unsupported span when fully loaded. Side jambs and pocket framing must be constructed of a continuous flat solid surface that is plumb.

Marvin Windows and Doors understands the importance and related complexities of the site preparation. Marvin Windows and Doors recommends that an authorized installer consult with the retailer and general contractor to discuss construction of the Lift and Slide Door opening.

The Marvin Lift and Slide Performance Sill door system creates inherent complexities for installation and introduces new terminology. The following illustrations are provided for clarification: (Reference Architectural Detail Manual for snap line definitions.)

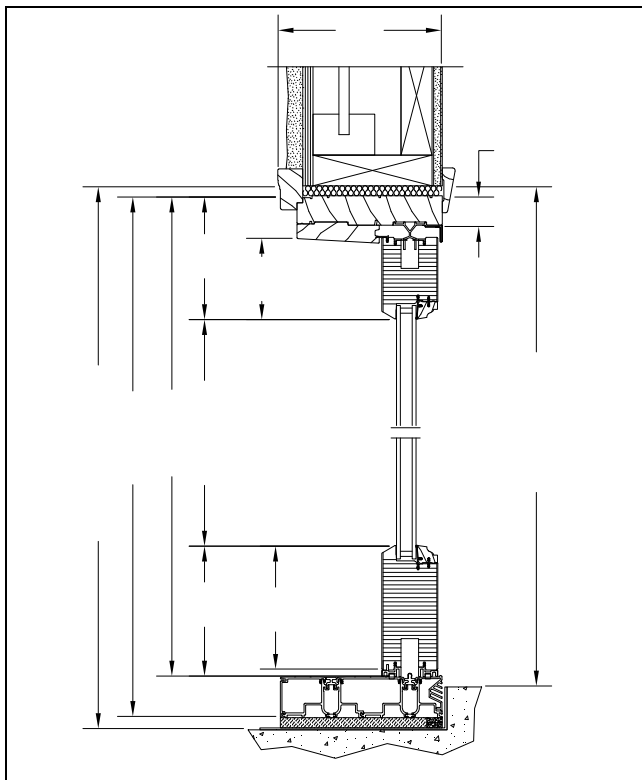

Open Face Slot Application

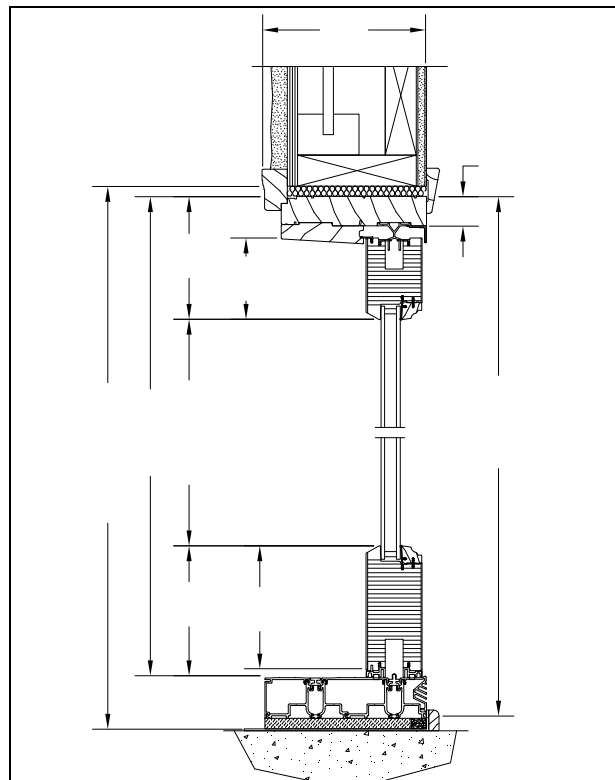

Sub Floor Application

Open Face Slot Depth, Width and Recess

The slot required for the recessed Performance Sill system should be within 1/4" (6) level across the door opening. The key element is that the finished floor height and finished floor thickness must be accounted for prior to preparing the slot. The dimensions of the open face slot are determined by the configuration of the Lift and Slide door system to be installed, as well as the available 0" - 2" (0 - 51) floor thickness. See illustrations below for examples.



Open face slot with wood construction. Slot recess is 3/8" (10). Available flooring is 2" (51) however 3/4" (19) hardwood flooring is used leaving 1 1/4" (32) sill face exposed.



Pocket application of open face slot in wood construction showing 1" (25) slot recess. Available flooring is 1 3/8" (35). Flooring used is 1/4" (6) leaving 1 1/8" (29) sill face exposed.

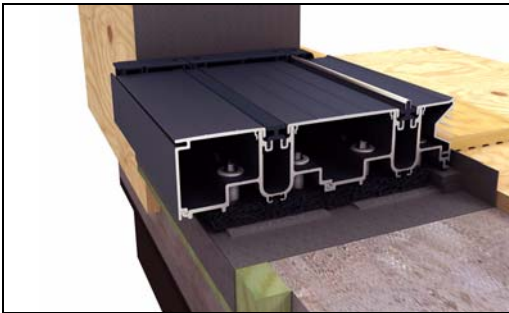

Open face slot with concrete construction. Slot recess is 3/8" (10). Available flooring is 2" (51) however 3/4" (19) hardwood flooring is used leaving 1 1/4" (32) sill face exposed.



Pocket with open face slot in concrete with a 2 3/8" (60) slot recess leaving 0" available floor thickness. The concrete is the finished floor and flush with the top of the sill.

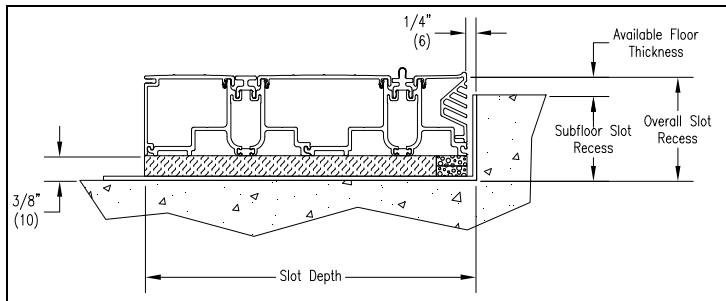

Number of Tracks	Slot Depth (minimum)
1	4 5/16" (125)
2	8 1/8" (206)
3	11 15/16" (303)
4	15 13/16" (402)

Available Floor Thickness	Sub-Floor Slot Recess
0"	2 3/8" (60)
1/4" (6)	2 1/8" (54)
1/2" (13)	1 7/8" (48)
3/4" (19)	1 5/8" (41)
1" (25)	1 3/8" (35)
1 1/4" (32)	1 1/8" (29)
1 1/2" (38)	7/8" (22)
1 3/4" (44)	5/8" (16)
2" (51)	3/8" (10)