

# Window Rough Opening Prep and Flashing Method A1-Membrane Drainage System

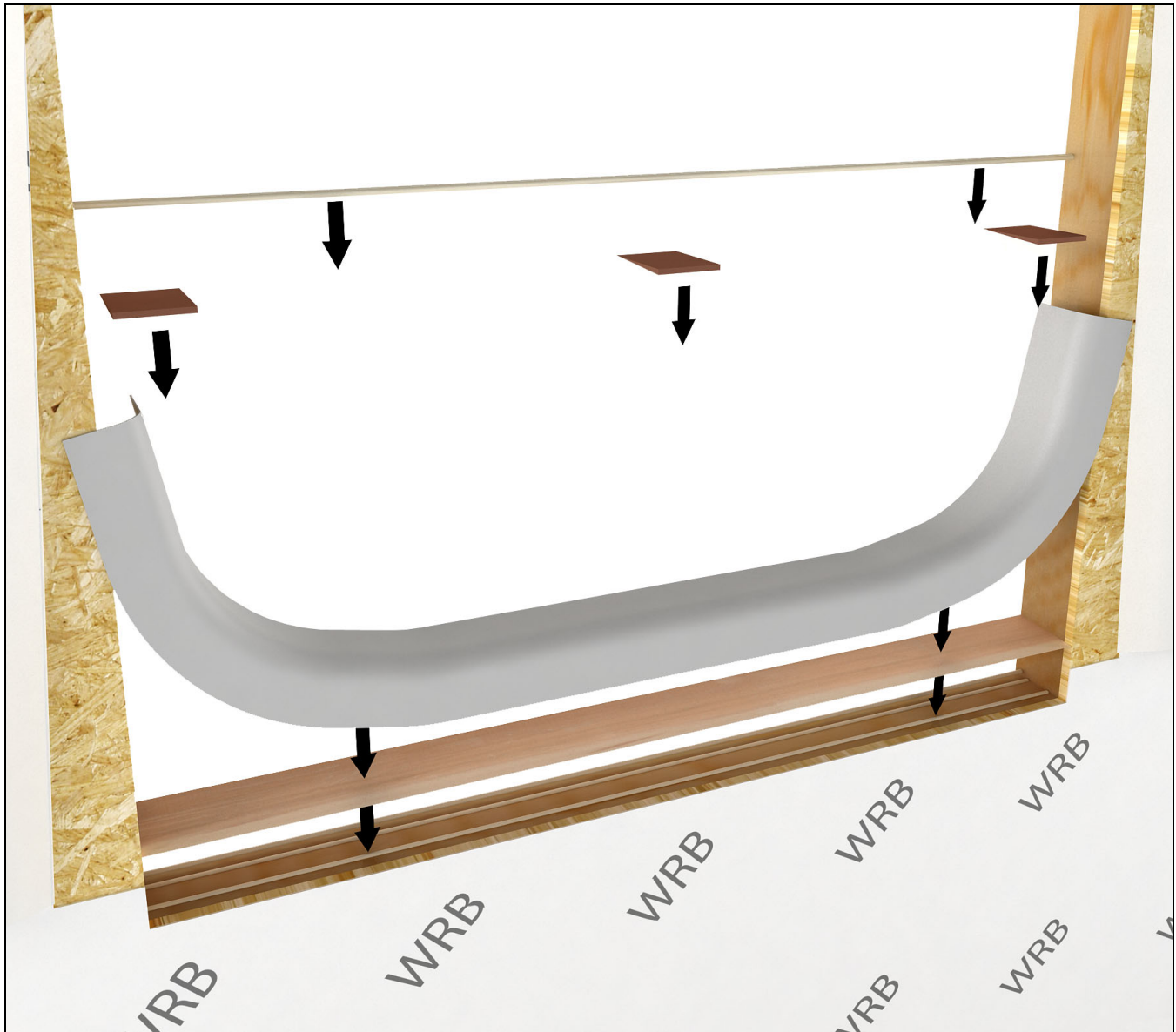

**ABSTRACT:** Please read these instructions in their entirety before beginning to install your Marvin, Integrity, or Infinity Window product. These installation instructions demonstrate the proper rough opening preparation (RO prep) in new wood frame construction using an industry approved water management system. For RO prep and installation using other construction methods, such as remodeling, replacement, and recessed openings refer to "ASTM E2112, Standard Practice for Installation of Exterior Windows, Doors, and Skylights." for suggestions. Information for ASTM E2112 can be found on the ASTM website, [www.astm.org](http://www.astm.org). Method A1 applies to non-integral flanged and wood windows. Weather Resistant Barrier (WRB) is to be applied prior to window installation. Head jamb flashing will be applied over the face of the non-integral mounting flange. The sill pan flash detailed within is a TYPE III (flexible membrane).

# Table of Contents

---

Note to Installer .....	3
Cutting the Weather Resistive Barrier (WRB) and Pan Flashing .....	4
Flashing the Installation .....	6
Insulating and Sealing the Installation-Nailing Fin .....	9
Insulating and Sealing the Installation-Casing .....	10
Exterior Sealing Procedures .....	11

## Note to Installer

Consideration of the window installation and wall as a system is important. The recommended method in these instructions and referenced elsewhere are intended to do just that. These details follow the concept that stopping air flow into the RO cavity will aid in managing water intrusion. Striving to form a continuous air barrier, water drainage plane, an insulation barrier, and a continuous vapor barrier is best practice; matching the window installation to the design of the actual wall system.

These details show a TYPE III flash pan (flexible membrane) and were based on ASTM E2112. This is one way to prep and flash a sill. Your situation may be different from those shown here. In that case we recommend that you reference other details found in ASTM E2112.

Other types of panning are:

- TYPE I: Rigid sheet, 1 piece or multiple pieces
- TYPE II: Rigid sheet, multiple pieces
- TYPE IV: Combination rigid flexible membrane (multiple pieces).
- Type V: Liquid applied flashing

## Supplies Needed

- Safety glasses
- Level
- Hammer
- Insulation
- Perimeter sealant
- Plastic or composite shims
- Backing material (foam backign rod)

## Materials Used

The following materials were used to develop these instructions. Other materials may be used but must be compatible with one another. Refer to each product's technical specification for compatibility and usage:

- Weather Resistant Barriers (WRB): DuPont™ Tyvek® HomeWrap
- Panning Material: DuPont™ FlexWrap NF®
- Flashing Materials: DuPont™ Flashing Tape (butyl)
- Insulation: Dow™ GreatStuff Pro™ foam insulation, loose fill fiberglass insulation.

### ATTENTION

Plan your rough opening carefully. The use of panning will affect the rough opening height clearance.

### IMPORTANT

Regional standard practices, environmental conditions, and codes may vary and supersede the procedures contained within. The responsibility for compliance is yours: the installer, inspector, and owner(s).

### WARNING!

Always practice safety! Wear the appropriate eye, ear and hand protection, especially when working with power tools.

- Flashing materials
- Weather resistive barrier (WRB)
- Hearing protection
- Square
- Sill pan flash
- Tape measure

*NOTE: Foam should be minimal expanding, low compression, closed cell foam and compliant with ASTM E2112, sec. 5.9.2.*

- Sealant: OSI® Quad Pro-Series® ; solvent release butyl rubber sealant or DAP DynaFlex230™

*NOTE: Sealant must be compliant with ASTM C920 Grade NS Class 25.*

- Other Materials: DuPont™ Seam Seal Tape® beveled siding product, and various fasteners noted within.

## Cutting the Weather Resistive Barrier (WRB) and Pan Flashing

**NOTE:** This does not apply to self-adhering WRB sheathing systems.

1. Make horizontal cuts to the Weather Resistive Barrier (WRB) across the top and bottom of the Rough Opening. Make a vertical cut down the center of the RO. then make 45 degree cuts away from the corners of the top of the RO. See Figure 1.

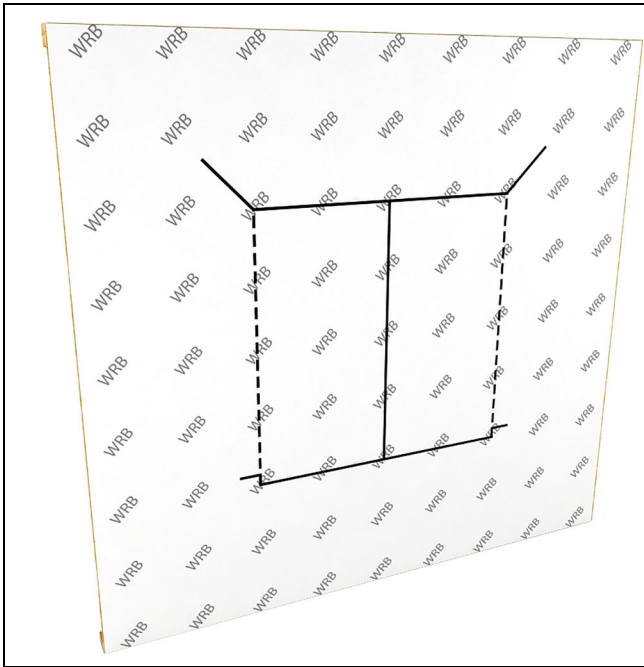

Figure 1

2. Trim up from the bottom corners about 2" (51) and then make an additional horizontal cut about 3 1/2" (89) wide. See Figure 2.

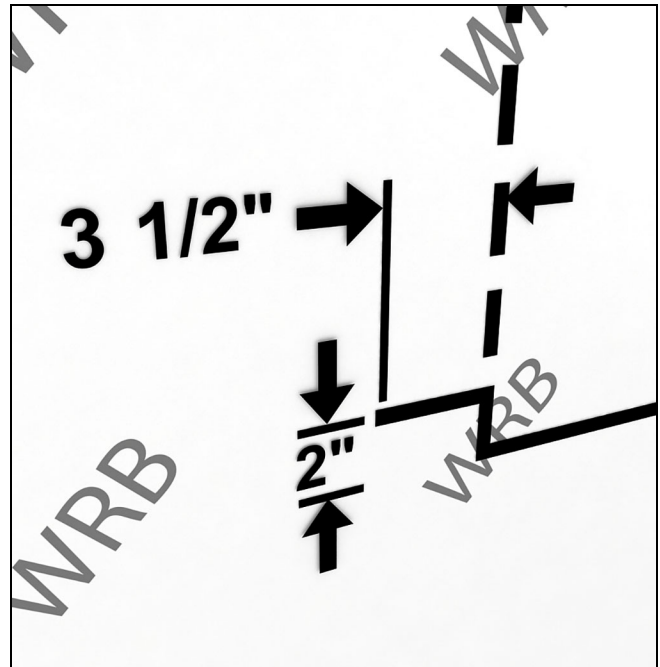

Figure 2

3. Flip the top up and side flaps away and tack temporarily. See Figure 3.



Figure 3

4. Optional: Add a continuous "Sill Wedge" out of cedar siding or similar water resistant material to create a positive drainage slope. Glue it to the RO sill with two beads of adhesive and screw in place. See Figure 4.

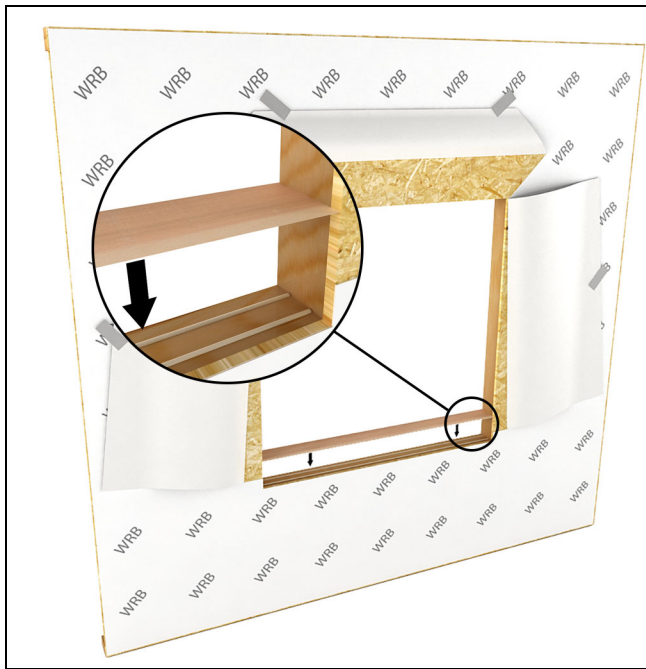

Figure 4

NOTE: This will affect your RO height, plan accordingly.

5. TYPE III Sill Pan Flash: Apply self sealing flexible membrane slope. See Figure 5.

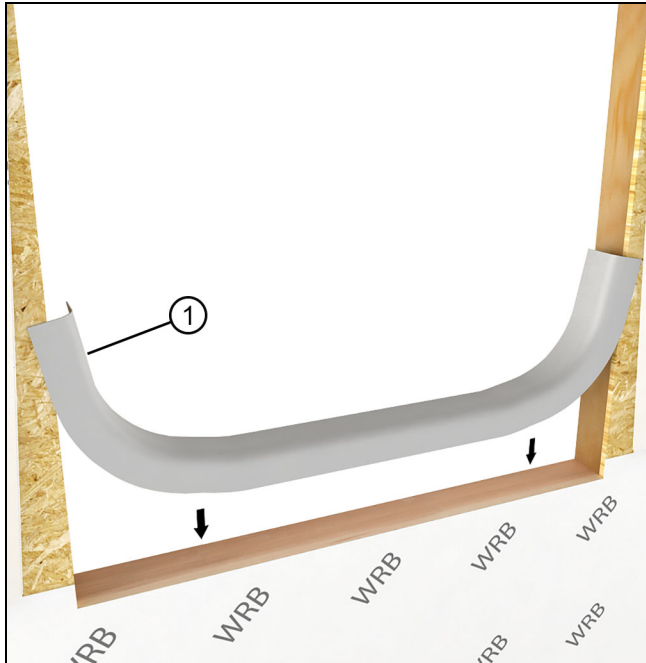

Figure 5

1	Flexible flashing membrane
---	----------------------------

NOTE: Some situations call for an upturned leg at the interior. If that is the case, do so using the excess sill flashing membrane to the interior.

6. Wrap side flaps to the interior and staple in place about 1 1/2" (38) from the interior edge of the opening. Cut the excess off near the staple so that a 1" - 1 1/2" (25-38) strip of bare wood is exposed. Tape this edge with seam seal tape. See Figure 6.

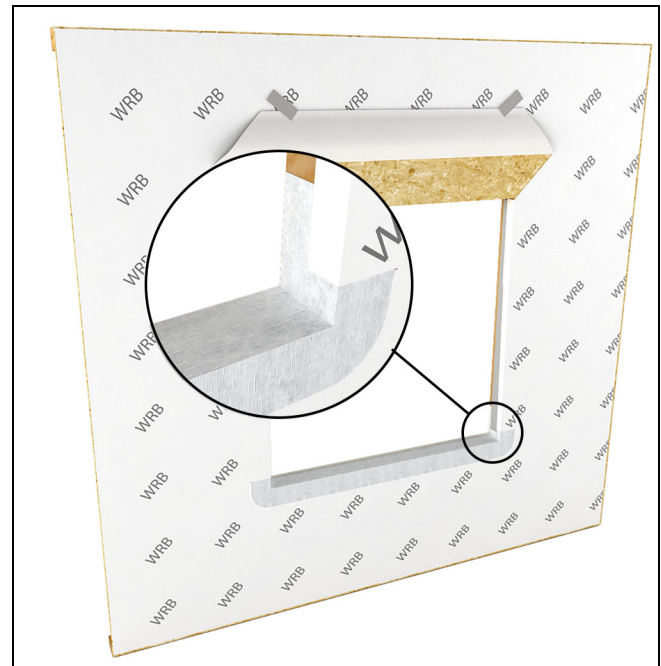

Figure 6

7. Apply seam seal tape over the corners. Place plastic or composite shims at the ends and in the middle of the RO to counter the slope of the sill wedge and support the unit. Fasten with adhesive or finish nails. If using finish nails, place adhesive under shim where the nail will penetrate. See Figure 7.

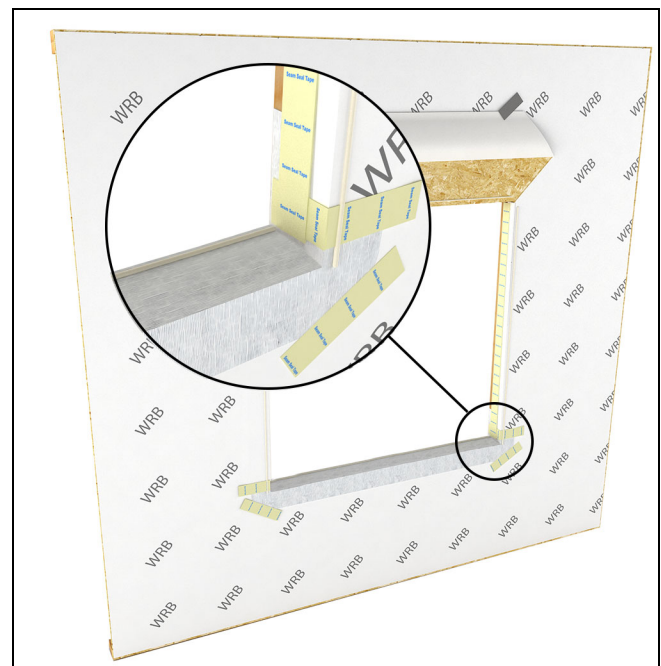

Figure 7

## Flashing the Installation

### IMPORTANT

Nailing fin is not designed to be a weatherproof flashing.

### IMPORTANT

Follow the flashing tape manufacturer's recommended instructions for attaching to the building materials under the WRB. For example, priming wet or frozen wood, application temperature, etc.

1. On units that use nailing fin, apply a 2" x 4" strip of flashing material at 45 degrees to the corner, bridging the gap between the nailing fin. Do this at all 4 corners. See [Figure 8](#).

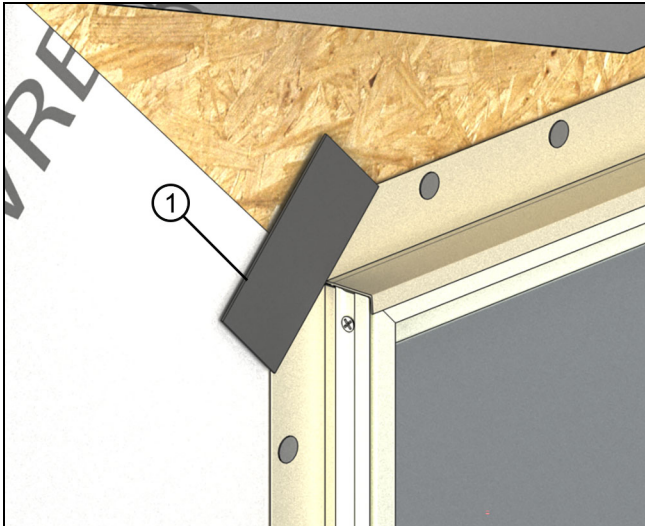

Figure 8

1	2" x 4" strip of flashing material
---	------------------------------------

2. If using the factory applied vinyl drip cap, make sure it extends about 1/8" (3) beyond the edge of the window on each side.

### IMPORTANT

If your unit does not come with an integrated drip cap, install a rigid drip cap supplied by others as shown in the [next step](#).

3. **Optional:** Install a rigid head flash. Seal both horizontal and vertical legs of the rigid head flash. See [Figure 9](#) and [Figure 10](#).

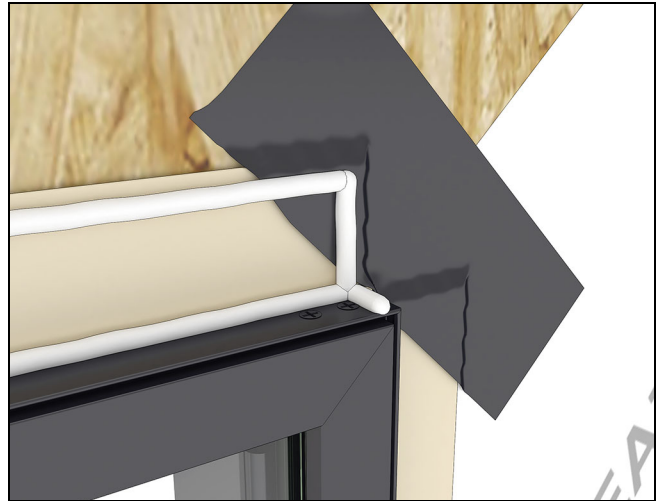

Figure 9

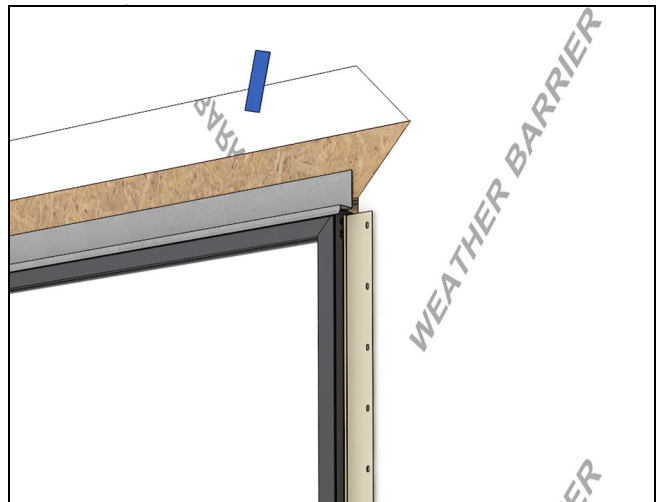

Figure 10

4. Apply a bead of sealant beneath the vinyl drip cap along the top of the head jamb as shown in [Figure 11](#)

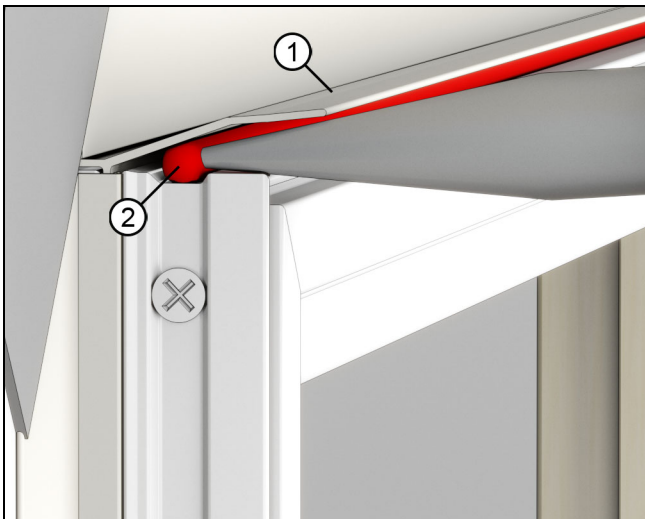

Figure 11

1	Vinyl drip cap
2	Sealant

**5. Optional Skirt:** Install an optional "skirt" in applications with exposure to wind driven rain/climate. Use flashing material or a 12" (305) strip of WRB and attach to the sill of the window with seam seal tape or flashing tape. See Figure 12.

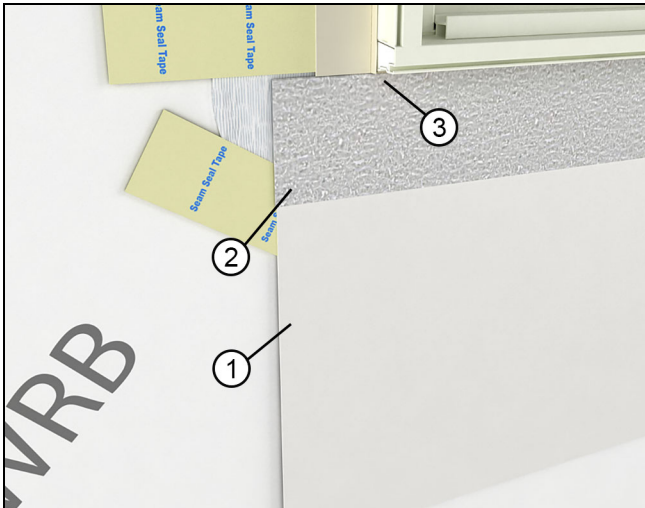

Figure 12

1	Skirt (WRB material or other)
2	Adhesive tape
3	Attached to sill of window

**6.** Lap vertical strips of adhesive flashing tape onto the unit and out over the WRB. Make small diagonal cuts at the head jamb as in Figure 13 to allow the membrane to fold back onto the exterior and frame.

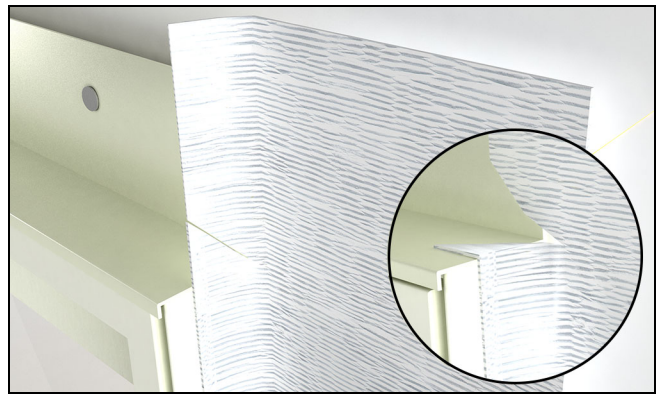

Figure 13

**7.** Install another layer of adhesive membrane lapping onto the head jamb of the unit and over the sheathing. The membrane flashing at the head jamb should extend and cover the flashing previously installed at the jambs. Make relief cuts and fold down so that it wraps around the jamb See Figure 14 and Figure 15.

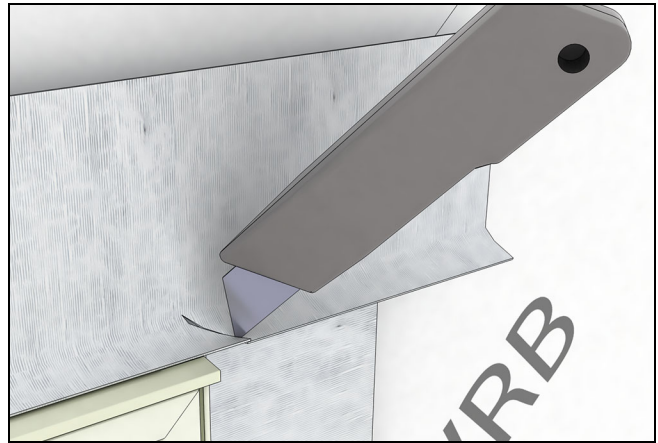

Figure 14

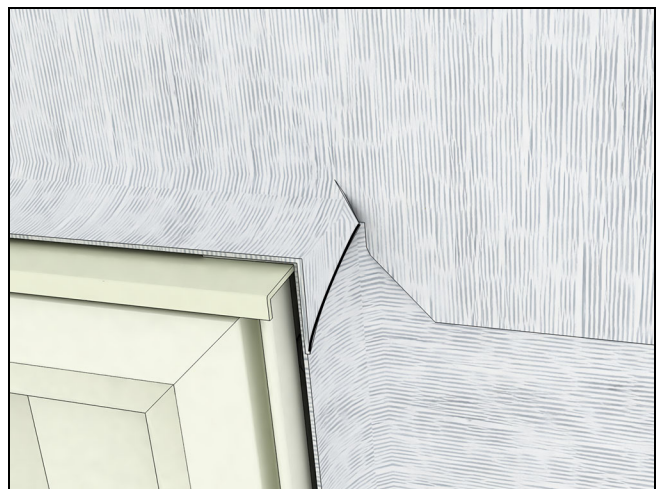

Figure 15

**8.** Tape the top edge of the head jamb flashing with seam seal tape. See Figure 16.

*NOTE: This does not apply to self adhered WRB.*



**Figure 16**

**9.** Seal the ends of the vinyl drip cap or rigid head flash, by injecting sealant at each end. [See Figure 17.](#)

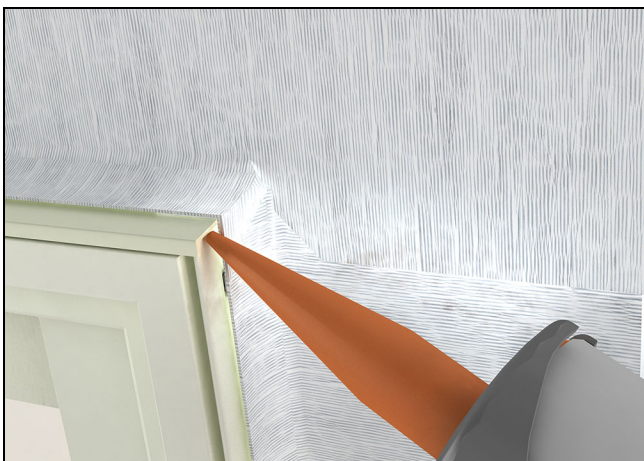

**Figure 17**

**10.** Fold the head jamb WRB down over the head jamb flashing. Apply seam seal tape over the diagonal cut in the WRB. Make sure the seam seal tape laps onto the unit or casing. Tape any seams and fasteners directly above the unit with seam seal tape. [See Figure 18.](#)

*NOTE: This does not apply to self adhered WRB.*



**Figure 18**

**11.** On Round Top units, flash the head jamb using a flexible membrane. [See Figure 19.](#)

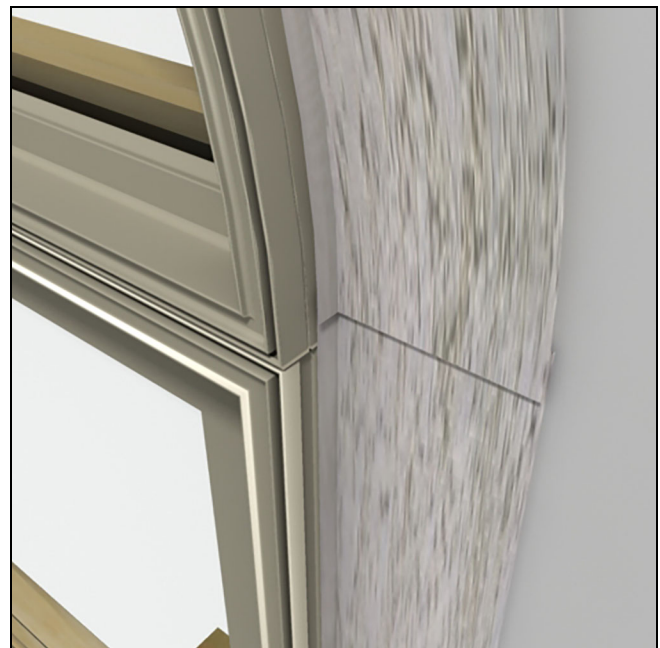

**Figure 19**

## Insulating and Sealing the Installation-Nailing Fin

We recommend two ways of insulating and sealing the rough opening cavity. Both follow the principle that stopping air intrusion will aid in managing water intrusion into the RO.

**1. Loose Fill Fiberglass Insulation.** Insulate the RO cavity with loose fill fiberglass insulation. Install a backer rod and sealant at the interior plane of the RO to create a continuous air seal. See Figure 20.

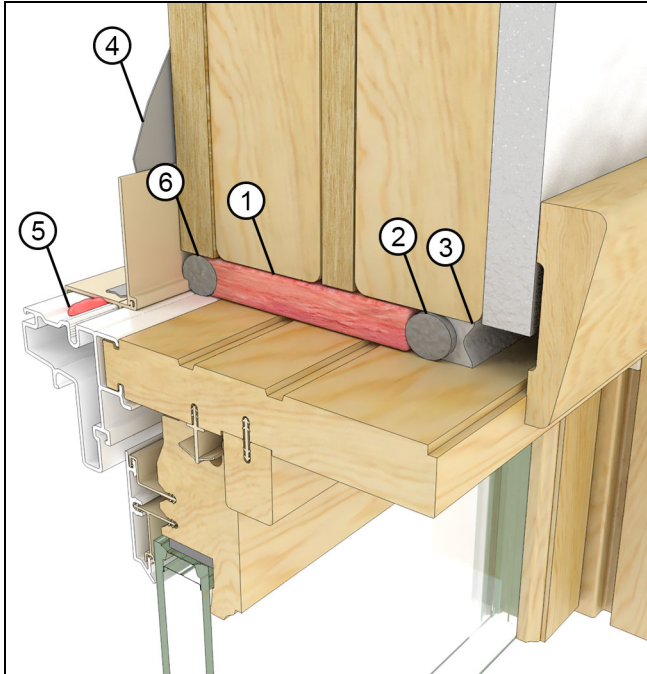

Figure 20

1	Loose fill fiberglass insulation
2	Backer rod
3	Continuous air seal (sealant)
4	Flashing
5	Sealant underneath drip
6	Backer rod (optional)

**2. Low Expansion Foam.** Install an optional backer rod at the exterior plane of the RO. Apply a low expansion/low compression closed cell foam in the cavity. Install a backer rod and sealant at the interior plane of the RO to create a continuous air seal. See Figure 21.

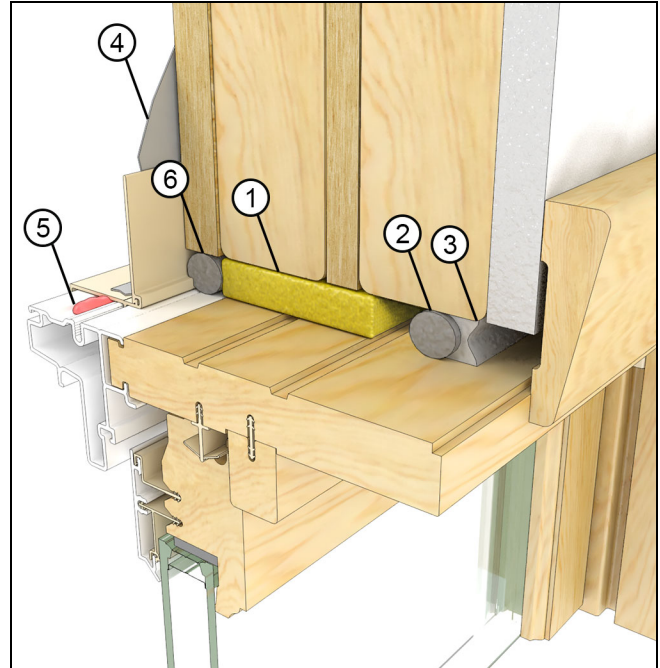

Figure 21

1	Low expansion foam
2	Backer rod
3	Continuous air seal (sealant)
4	Flashing
5	Sealant underneath drip cap
6	Backer rod (optional)

## Insulating and Sealing the Installation-Casing

We recommend two ways of insulating and sealing the rough opening cavity. Both follow the principle that stopping air intrusion will aid in managing water intrusion into the RO.

**1. Loose Fill Fiberglass Insulation.** Insulate the RO cavity with loose fill fiberglass insulation. Install a backer rod and sealant at the interior plane of the RO to create a continuous air seal. See Figure 20.

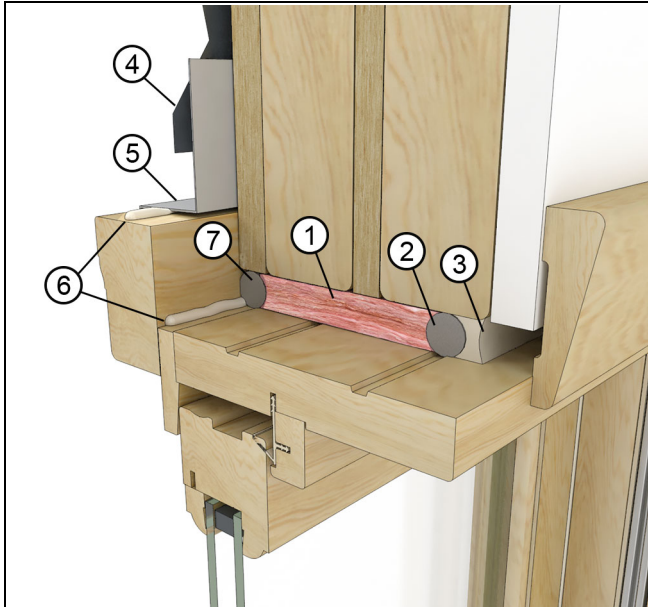

Figure 22

1	Loose fill fiberglass insulation
2	Backer rod
3	Continuous air seal (sealant)
4	Flashing
5	Rigid head flash
6	Sealant
7	Backer rod (optional)

**2. Low Expansion Foam.** Install an optional backer rod at the exterior plane of the RO. Apply a low expansion/low compression closed cell foam in the cavity. Install a backer rod and sealant at the interior plane of the RO to create a continuous air seal. See Figure 21.

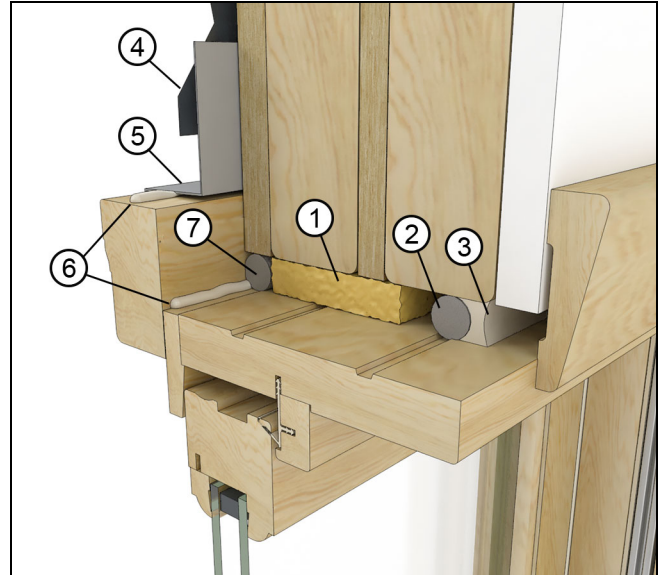

Figure 23

1	Low expansion foam
2	Backer rod
3	Continuous air seal (sealant)
4	Flashing
5	Rigid head flash
6	Sealant
7	Backer rod (optional)

## Exterior Sealing Procedures

1. For ALL applications: Once the exterior finish such as siding or brick veneer is installed, apply bead of sealant between the finish and the frame exterior or casing along the sides. Apply additional beads approximately 1"- 2" (25-51) at the ends on top of the drip cap. Use a backer rod when necessary. See [Figure 24](#) and [Figure 25](#).

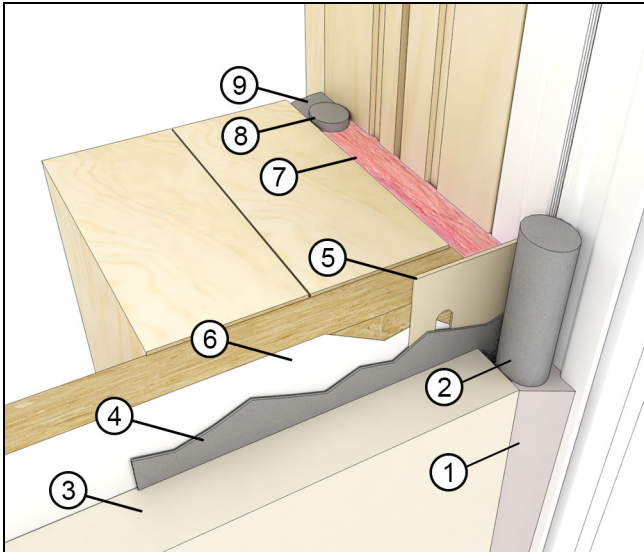

Figure 24

1	Exterior sealant
2	Backer rod
3	Exterior cladding/finish
4	Flashing
5	Nailing Fin
6	Weather resistive barrier
7	Insulation
8	Backer rod
9	Interior air seal



Figure 25 Apply sealant between unit and exterior finish at head jamb.

## ! CAUTION!

Perimeter sealant must be Grade NS Class 25 per ASTM C920 and compatible with the window product and the finished exterior(s) of the building. Using improper sealant could result in sealant failure causing air and water infiltration.